CH7517 DisplayPort to VGA Converter

FEATURES

- Compliant with DisplayPort specification version 1.2 and Embedded DisplayPort (eDP) specification version 1.3.
- Support 2 Main Link Lanes at either 1.62Gb/s or 2.7Gb/s link rate
- Support analog RGB output for VGA with Triple 9-bit DAC up to 200MHz pixel rate. Sync signals can be provided in separated or composite manner. Support VESA and CEA timing standards up to 1920x1200@60Hz or 2048x1152@60Hz with reduced blanking
- VGA output is compliant with VESA VSIS v1r2 specification
- Embedded MCU to handle the control logic
- Support device boot up by automatically loading firmware from on-chip flash Boot ROM
- Integrated EDID Buffer, and MCCS bypass supported
- Supports Enhanced Framing Mode
- Fast and full Link Training for embedded DisplayPort system
- Support eDP Authentication: Alternative Scramble Seed Reset and Alternative Framing
- 2 work modes: connect 27MHz crystal, inject 27MHz clock
- DAC connection detection supported
- DP input detection supported
- Support Auto Power Saving mode and low stand-by current
- Support Spread Spectrum Clocking (de-spreading) for EMI reduction
- DP AUX channel and IIC slave interface are available for firmware update and debug
- Low power architecture
- 3.3V/1.05V power supply supported for motherboard solution design
- RoHS compliant and Halogen free package
- Offered in 40-Pin QFN package (5 x 5 mm)

APPLICATION

- Notebook/Ultrabook
- Tablet Device
- Handheld/Portable Device
- PC

GENERAL DESCRIPTION

Chrontel's CH7517 is a low-cost, low-power semiconductor device that translates the DisplayPort signal to the VGA. This innovative DisplayPort receiver with an integrated VGA encoder is specially designed to target the notebook/ultrabook, tablet device and PC market segments. Through the CH7517's advanced decoding / encoding algorithm, the input DisplayPort high-speed serialized multimedia data can be seamlessly converted to analog RGB video output.

The CH7517 is compliant with the DisplayPort specification version 1.2 and the Embedded DisplayPort Specification version 1.3. In the device's receiver block, which supports two DisplayPort Main Link Lanes input with data rate running at either 1.62Gb/s or 2.7Gb/s, can accept RGB digital formats in either 18-bit 6:6:6 or 24-bit 8:8:8, and converted the input signal to VGA output up to 1920x1200@60Hz or 2048x1152@60Hz with reduced blanking. Leveraging the DisplayPort's unique source/sink "Link Training" routine, the CH7517 is capable of instantly bring up the video display to the VGA monitor when the initialization process is completed between CH7517 and the graphic chip.

The DACs are based on current source architecture. And the VGA output meet VESA VSIS v1r2 clock jitter target. With sophisticated MCU and the on-chip Flash, CH7517 support auto-boot and EDID buffer. After the configuration by firmware, which is auto loaded from the Flash embedded, CH7517 supports DisplayPort input detection, DAC connection detection and determine to enter into power saving mode automatically.

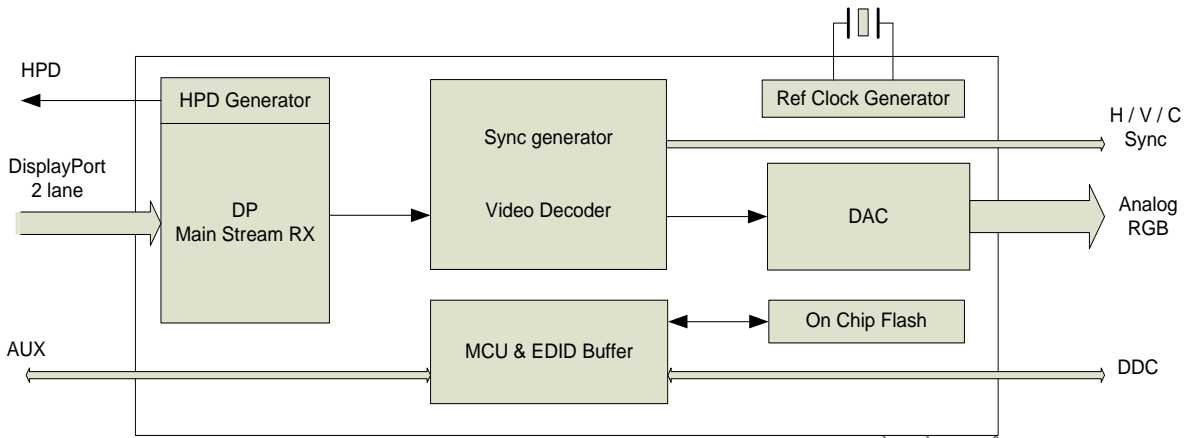

Figure 1: CH7517 Functional Block Diagram

CONFIDENTIAL
DO NOT COPY

1.0 PIN-OUT

1.1 Package Diagram

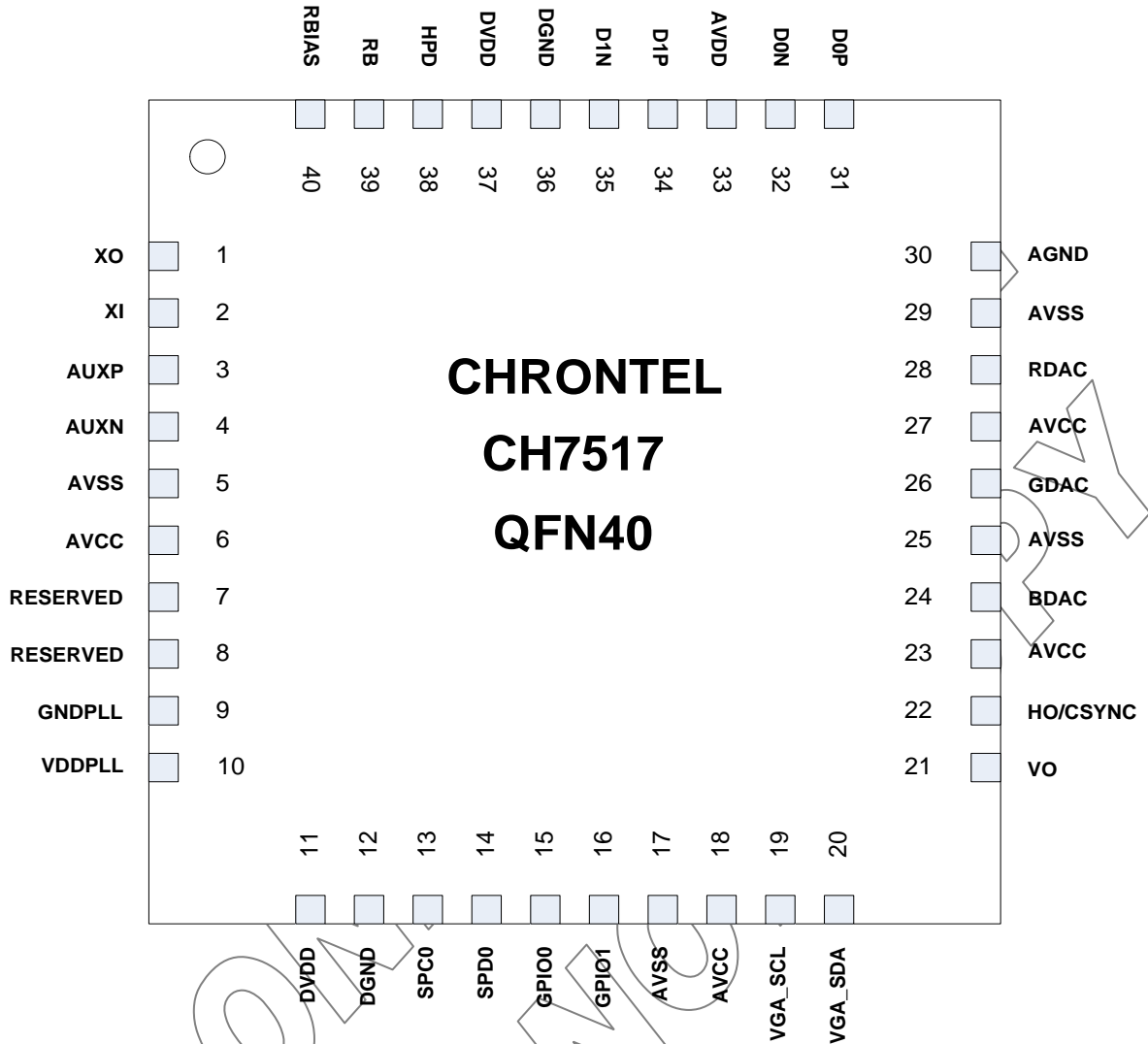

Figure 2: CH7517 40-pin QFN pin out

1.2 Pin Description

Table 1: Pin Name Descriptions

Pin #	Type	Symbol	Description
1	Out	XO	Crystal Output A parallel resonance crystal should be attached between this pin and XI. If an external CMOS clock is injected to XI, XO should be left open.
2	In	XI	Crystal Input A parallel resonance crystal should be attached between this pin and XO.
3,4	In/Out	AUXP/N	DisplayPort AUX Port These two pins are DisplayPort AUX Channel control, which supports a half-duplex, bi-directional AC-coupled differential signal.
7,8		RESERVED	Reserved Pins
13	In	SPC0	Serial Port Clock Input This pin functions as the clock pin of the serial port. External pull-up 6.8 K Ω resistor is required
14	In/out	SPD0	Serial Port Data Input / Output This pin functions as the bi-directional data pin of the serial port. External pull-up 6.8 K Ω resistor is required
15	In/Out	GPIO0	General Purpose Input/Output
16	In/Out	GPIO1	General Purpose Input/Output
19	Out	VGA_SCL	Serial Port Clock Output to VGA Receiver The pin should be connected to clock signal of VGA DDC. This pin requires a pull-up 10 k Ω resistor to the desired voltage level
20	In/Out	VGA_SDA	Serial Port Data to VGA Receiver The pin should be connected to data signal of VGA DDC. This pin requires a pull-up 10 k Ω resistor to the desired voltage level
21	Out	VO	VGA VSYNC Output
22	Out	HO/CSYNC	VGA HSYNC/CSYNC Output XOR Gate is default
24	Out	BDAC	Blue Component Output
26	Out	GDAC	Green Component Output
28	Out	RDAC	Red Component Output
31,32	In	D0P/N	DP Rx Input Lane 0
34,35	In	D1P/N	DP Rx Input Lane 1
38	Out	HPD	DP Receiver Hot Plug Output
39	In	RB	Chip Reset Low to 0V for reset. Typical High level is 3.3V
40	In	RBIAS	Current Set Resistor Input This pin sets the DAC current. A 10K Ω , 1% tolerance resistor should be connected between this pin and AVSS using short and wide traces
6,18,23,27	Power	AVCC	Analog Power Supply (3.3V)
5,17,25,29, Pad	Power	AVSS	Analog Power Ground
9,	Power	GNDPLL	PLL Power Ground
10	Power	VDDPLL	PLL Power Supply (1.05~1.2V)
11,37	Power	DVDD	Digital Power Supply (1.05~1.2V)

12,36	Power	DGND	Digital Ground
30	Power	AGND	Analog Power Ground
33	Power	AVDD	Analog Power Supply (1.05~1.2V)

CONFIDENTIAL
DO NOT COPY

2.0 PACKAGE DIMENSION

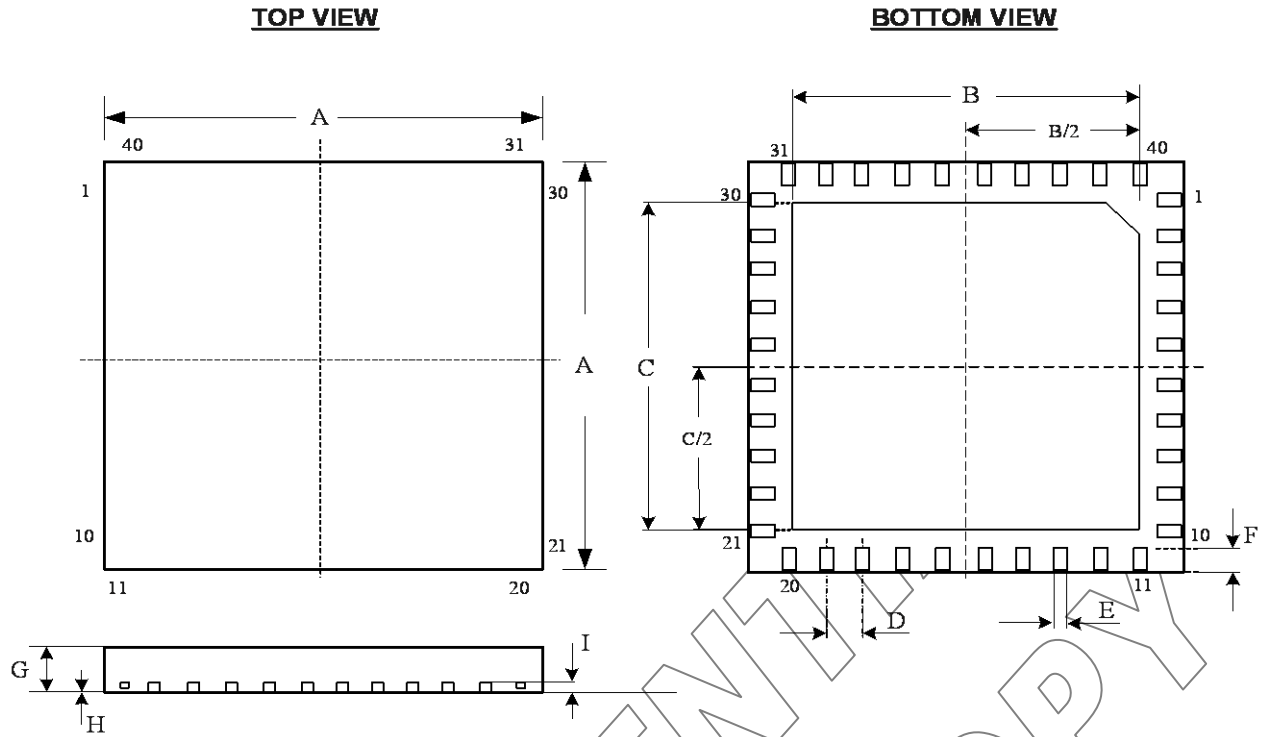

Figure 3: 40 Pin QFN Package

Table 2: Table of Dimensions

No. of Leads		SYMBOL								
40 (5 X 5 mm)		A	B	C	D	E	F	G	H	I
Milli-meters	MIN	4.90	3.20	3.20	0.40	0.15	0.35	0.70	0.00	0.203
	MAX	5.10	3.40	3.40		0.25	0.45	0.80	0.05	REF

Notes:

Conforms to JEDEC standard JESD-30 MO-220.

Disclaimer

This document provides technical information for the user. Chrontel reserves the right to make changes at any time without notice to improve and supply the best possible product and is not responsible and does not assume any liability for misapplication or use outside the limits specified in this document. CHRONTEL warrants each part to be free from defects in material and workmanship for a period of one (1) year from date of shipment. Chrontel assumes no liability for errors contained within this document. The customer should make sure that they have the most recent data sheet version. Customers should take appropriate action to ensure their use of the products does not infringe upon any patents. Chrontel, Inc. respects valid patent rights of third parties and does not infringe upon or assist others to infringe upon such rights.

Chrontel PRODUCTS ARE NOT AUTHORIZED FOR AND SHOULD NOT BE USED WITHIN LIFE SUPPORT SYSTEMS OR NUCLEAR FACILITY APPLICATIONS WITHOUT THE SPECIFIC WRITTEN CONSENT OF Chrontel. Life support systems are those intended to support or sustain life and whose failure to perform when used as directed can reasonably expect to result in personal injury or death.

ORDERING INFORMATION			
Part Number	Package Type	Operating Temperature Range	Minimum Order Quantity
CH7517A-BF	40 QFN, Lead-free	Commercial : 0 to 70°C	490/Tray
CH7517A-BFI	40 QFN, Lead-free	Industrial : -40 to 85°C	490/Tray

Chrontel

Chrontel International Limited

**129 Front Street, 5th floor,
Hamilton, Bermuda HM12**

**www.chrontel.com
E-mail: sales@chrontel.com**

单击下面可查看定价，库存，交付和生命周期等信息

[>>Chrontel\(昆泰\)](#)