	<b>Cosemitech</b>	<b>CH910/CH910L</b>
	<b>Automotive Product Group</b>	<small>This is advanced information on a new product now in development or undergoing evaluation. Details are subject to change without notice and Cosemitech assumes no obligation for future manufacture of this product. Contact Cosemitech for the latest status.</small>

**Preliminary Datasheet 1.2**

<b>FEATURES and FUNCTIONAL DIAGRAM</b>	<b>PACKAGE</b>
--	----------------

- Micro-power Omnipolar-Switch Hall Sensor
- Multiple Sensitivity Options (BOP / BRP): ±36 / ±26 Gauss;
- Push-pull output ability
- Chopper stabilized design provides:
  - Superior temperature stability
  - Minimal switch point drift
  - Enhanced immunity to physical stress
- On board voltage regulator for 1.8V to 5.25V range
- Push-pull Output (1 mA current ability)
- Solid-state reliability
- Wide Operating temperature range: -40 to 125 °C
- Small package sizes TO-92S, SOT-23
- RoHS-compliant material meets directive 2011/65/EU

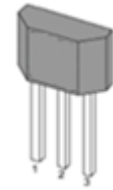
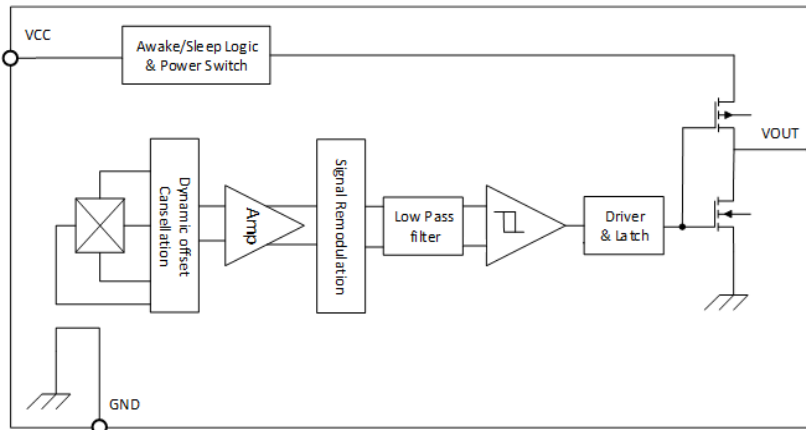

TO-92S

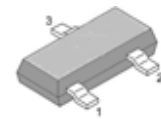

SOT-23-3L

**APPLICATIONS**

- Open and Close Detect for Flip/Slide Cellular Phones;
- Smart Cover or Dock Detect for Cellular Phones and Tablet PCs;
- Cover or Display Switch in Portable PCs (eg: Ultrabook);
- Digital Still, Video Cameras and Handheld Gaming Consoles;
- Door, Lids and Tray Position Switches;
- Level, Proximity and Position Switches;
- Contact-Less Switches in Home Appliances and Industrial Applications.

**DESCRIPTION**

The CH910/CH910L is a high-sensitivity extremely temperature-stable micro-power Omnipolar Hall effect switch IC with internal pull up and pull down capability. Designed for portable and battery powered consumer equipment such as cellular phones and portable PCs to office equipment, home appliances and industrial applications, the average supply current is only 1.62µA at 3,3V for CH910 and 0.92uA at 3.3V for CH910L. To support potable equipment, the CH910/CH910L can operate over the supply range of 1.8V to 5.5V and uses a hibernating clocking system to minimize the power consumption.

The device includes a clocking system, a Hall-voltage generator, a small-signal amplifier, a chopper stabilization, two Schmitt trigger, and an output driver controller.

The output is activated with either a north or south pole of sufficient magnetic field strength. When the magnetic flux density (B) perpendicular to the package is larger than operate point (Bop), the output will be turned on (pulled low) and held until B is lower than release point (Brp).

Two package styles provide a magnetically optimized package for most applications, SOT-23 and TO-92S. Each package type is lead (Pb) free (suffix, -T), with a 100% matte-tin-plated leadframe.

	<b>Cosemitech</b>	<b>CH910/CH910L</b>
	<b>Automotive Product Group</b>	<small>This is advanced information on a new product now in development or undergoing evaluation. Details are subject to change without notice and Cosemitech assumes no obligation for future manufacture of this product. Contact Cosemitech for the latest status.</small>

**Preliminary Datasheet 1.1**

## Table of Contents

1. Product Family Members .....		3
2. Pin Definitions and Descriptions .....		3
3. Absolute Maximum Ratings .....		3
4. ESD Protections.....		4
5. Function Description .....		4
6. Magnetic Activation.....		4
7. Temperature Characterization .....		6
8. Parameters Specification .....		6
9. Application information.....		7
10. Package Information .....		10

	<b>Cosemitech</b>	<b>CH910/CH910L</b>
	<b>Automotive Product Group</b>	<small>This is advanced information on a new product now in development or undergoing evaluation. Details are subject to change without notice and Cosemitech assumes no obligation for future manufacture of this product. Contact Cosemitech for the latest status.</small>

**Preliminary Datasheet 1.1**

### 1. Product Family Members

Part Number	Marking ID	Description
CH910SR	C910	Micro-power Omnipolar-Switch, Hall-effect digital sensor IC, SOT-23-3L package, tape and reel packing (3000 units per reel)
CH910TB	C910	Micro-power Omnipolar-Switch, Hall-effect digital sensor IC, flat, TO-92S package, bulk packing (1000 units per bag)
CH910LSR	910L	Micro-power Omnipolar-Switch, Hall-effect digital sensor IC, SOT-23-3L package, tape and reel packing (3000 units per reel)
CH910LTB	910L	Micro-power Omnipolar-Switch, Hall-effect digital sensor IC, flat, TO-92S package, bulk packing (1000 units per bag)

### 2. Pin Definitions and Descriptions

SOT-23-3L (S)	TO-92S (T)	Name	Type	Function
1	1	VDD	Supply	Supply Voltage pin
2	3	OUT	Output	Push-pull Output pin
3	2	GND	Ground	Ground pin

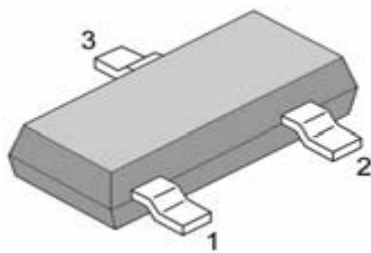

**SOT-23-3L**

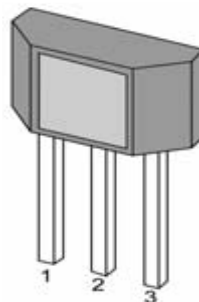

**TO-92S**

### 3. Absolute Maximum Ratings

Parameter	Symbol	Min	Max	Units
Supply Voltage	$V_{DD}$	-	6	V
VDD Reverse Voltage $V_{DD}$	$V_{RDD}$	-0.3		V
Supply Current	$I_{DD}$	-	3	mA
Output Voltage	$V_{OUT}$	-0.3	$V_{DD}+0.3$	V
Output Current	$I_{OUT}$	-	3	mA
Operating Ambient Temperature	$T_A$	-40	150	°C
Storage Temperature	$T_S$	-50	150	°C
Junction temperature	$T_J$	-50	165	°C
Magnetic Flux	B	No Limit		Gauss

Note: Exceeding the absolute maximum ratings may cause permanent damage. Exposure to absolute-maximum-rated conditions for extended periods may affect device reliability.

	<b>Cosemitech</b>	<b>CH910/CH910L</b>
	<b>Automotive Product Group</b>	<small>This is advanced information on a new product now in development or undergoing evaluation. Details are subject to change without notice and Cosemitech assumes no obligation for future manufacture of this product. Contact Cosemitech for the latest status.</small>

**Preliminary Datasheet 1.1**

#### 4. ESD Protections

Parameter	Value	Unit
All pins <sup>1)</sup>	+/-6000	V
All pins <sup>2)</sup>	+/-400	V
All pins <sup>3)</sup>	+/-1500	V

- 1) HBM (Human Body Mode) according to AEC-Q100-002
- 2) MM (Machine Mode) according to AEC-Q100-003
- 3) CDM (charged device mode) according to AEC-Q100-011

#### 5. Function Description

The CH910/CH910L exhibits Micro-power digital Omnipolar switching characteristics. Therefore, it requires only south poles or north poles to operate properly.

When the applied magnetic flux density exceeds the BOP threshold, the chip push-pull output goes low. The output stays low until the field decreases to less than BRP, and then the output goes to high.

A magnetic hysteresis BHYST keeps BOP and BRP separated by a minimal value. This hysteresis prevents output oscillation near the switching point.

#### 6. Magnetic Activation

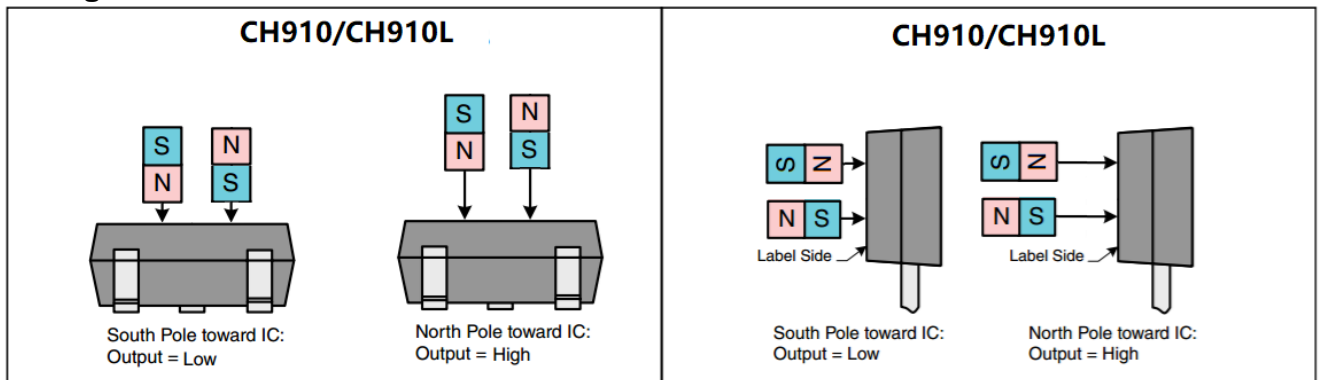

#### 7. Temperature Characteristics

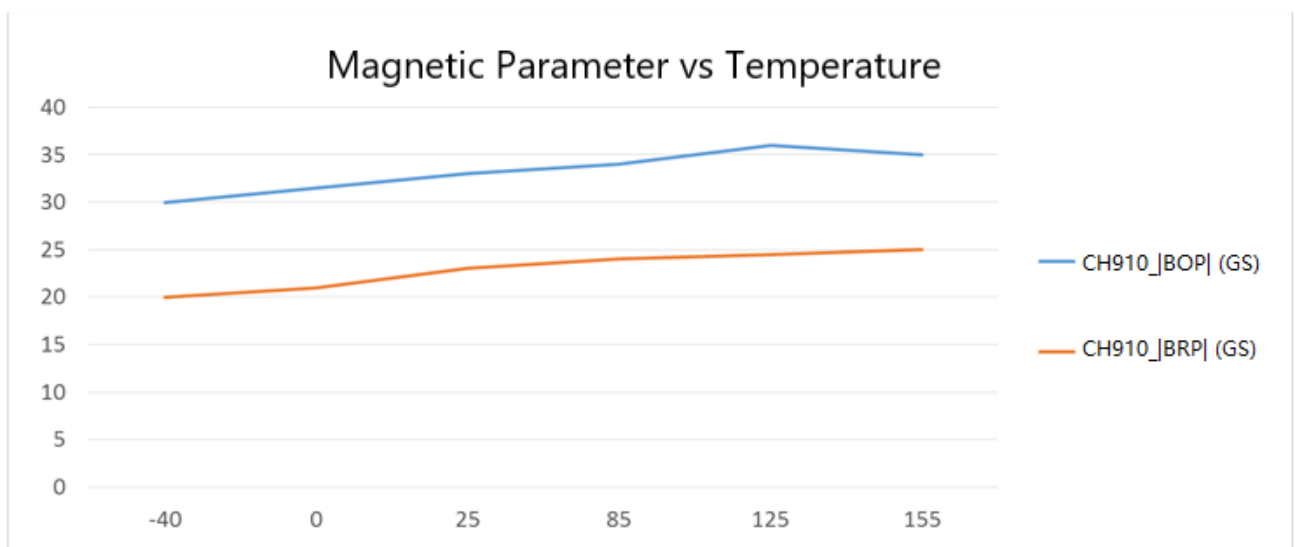

	<b>Cosemitech</b>	<b>CH910/CH910L</b>
	<b>Automotive Product Group</b>	<small>This is advanced information on a new product now in development or undergoing evaluation. Details are subject to change without notice and Cosemitech assumes no obligation for future manufacture of this product. Contact Cosemitech for the latest status.</small>

**Preliminary Datasheet 1.1**

**8. Parameters Specification (VCC=3V supply, TA= -40 °C to 125 °C except where otherwise specified.)**

Symbol	Characteristic	Test Conditions	Min.	Typ.	Max.	Unit
V <sub>CC</sub>	Supply Voltage	Operating, T <sub>J</sub> < 165°C	1.8		5.25	V
I <sub>CC(awake)</sub>	CH910 Supply Current	During awake period, TA = 25°C, VCC=3.3V	–	1.1	1.6	mA
	CH910L Supply Current		–	1.1	1.6	mA
I <sub>CC(sleep)</sub>	CH910 Supply Current	During sleep period, TA = 25°C, VCC=3.3V	–	0.7	–	uA
	CH910L Supply Current		–	0.7	–	uA
I <sub>CC(avg)</sub>	CH910 Average supply current	TA = 25°C, VDD = 1.8V		1.09		uA
		TA = 25°C, VDD = 3.3V		1.62		uA
	CH910L Average supply current	TA = 25°C, VDD = 1.8V		0.52		uA
		TA = 25°C, VDD = 3.3V		0.92		uA
V <sub>OL</sub>	Output low voltage(on)	I <sub>OUT</sub> = 1 mA	–	0.1	0.2	V
V <sub>OH</sub>	Output high voltage(off)	I <sub>OUT</sub> = -1mA	V <sub>CC</sub> -0.2	V <sub>CC</sub> -0.1	–	V
T <sub>awake</sub>	CH910 Awake time	(note3)	–	40	75	us
	CH910L Awake time	(note3)	–	40	75	us
T <sub>period</sub>	CH910 Period	(note3)	–	50	100	ms
	CH910L Period	(note3)	–	200	350	mS
D.C.	Duty cycle CH910	–	–	0.08	–	%
	Duty cycle CH910L	–	–	0.02	–	%
f <sub>c</sub>	Chopping Frequency		–	500	–	kHz
I <sub>OFF</sub>	Output Leakage Current	V <sub>OUT</sub> = 5.25V; Switch state = Off	–	–	1	μA
Bop	Operate point	VDD = 1.8V to 5.25V TA = 25°C	±20	±36	±75	Gauss
Brp	Release point	VDD = 1.8V to 5.25V TA = 25°C	±10	±26	±65	Gauss
Hys	Hysteresis	VDD = 1.8V to 5.25V	–	10	–	Gauss

		TA = 25°C				
--	--	-----------	--	--	--	--

- 1G (gauss) = 0.1 mT (millitesla).
- Measured from 10% to 90% of the steady state output.
- When power is initially turned on, the operating VCC (1.8V to 5.5V) must be applied to guaranteed the output sampling. The output state is valid after the second operating cycle (typical 100ms).

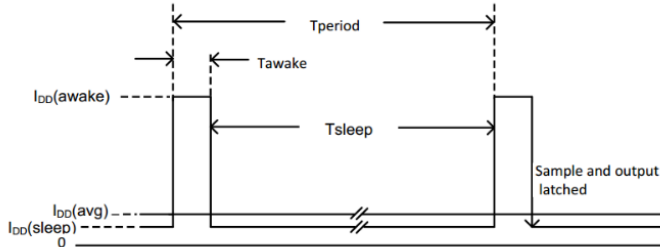

**NOTICE:** The magnetic field strength (Gauss) required to cause the switch to change state (operate and release) will be as specified in the magnetic characteristics. To test the switch against the specified magnetic characteristics, the switch must be placed in a uniform magnetic field.

**9. Application Information**

**9.1 Typical Application**

It is recommended that an external capacitor C<sub>IN</sub> is connected to the supply. This can reduce the noise injected into the device. Normal 0.1uF is suggested.

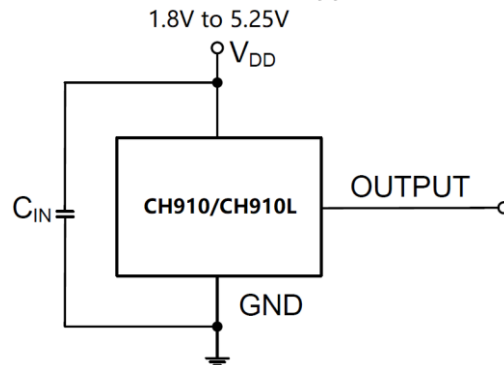

Typical Application Circuit

**9.2 Device Output**

If the device is powered on with a magnetic field strength between BRP and BOP, then the device output is indeterminate and can either be high or Low. If the field strength is greater than BOP, then the output is pulled low. If the field strength is less than BRP, then the output is pulled high.

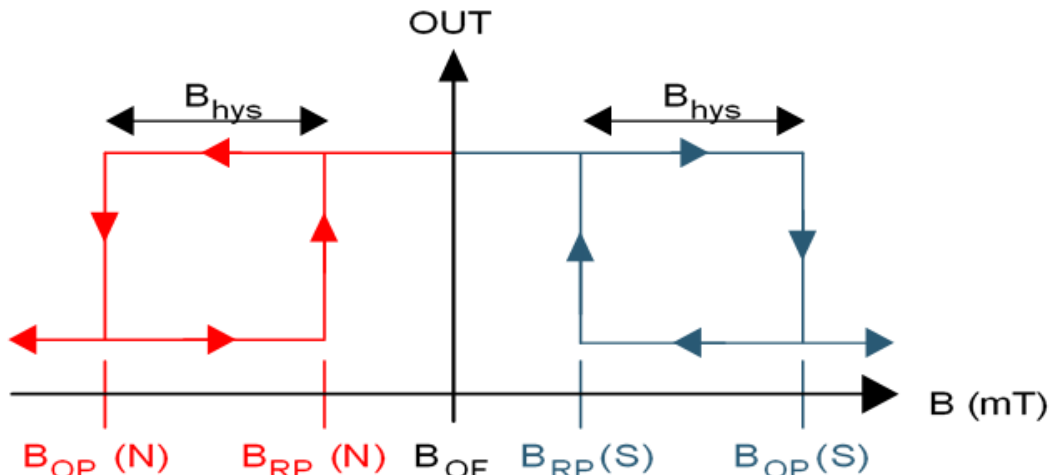

10. Package Information:

Package Designator  
TO-92S

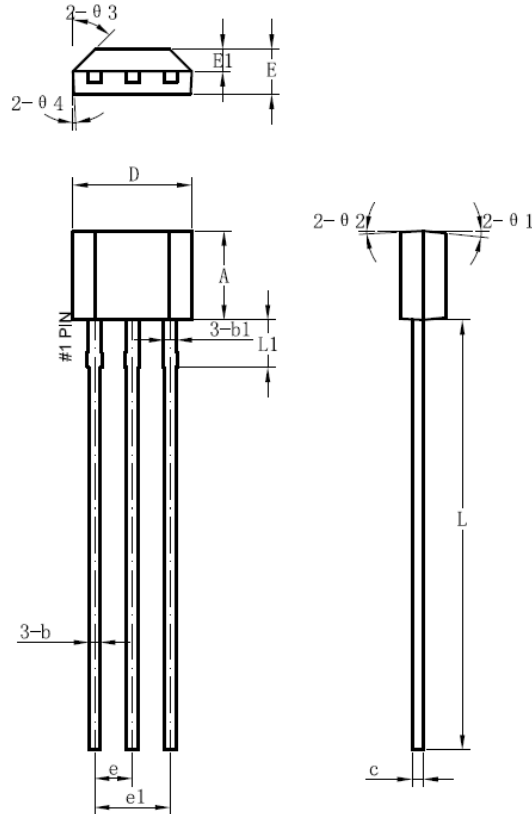

Symbol	Dimensions in Millimeters		
	Min.	Typ.	Max.
A	2.9	3	3.1
b	0.35	0.39	0.56
b1		0.44	
c	0.36	0.38	0.51
D	3.8	3.9	4.0
E	1.42	1.52	1.62
E1		0.75	
e		1.27	
e1		2.54	
L	13.5	14.5	15.5
L1		1.6	
$\theta 1$		6°	
$\theta 2$		3°	
$\theta 3$		45°	
$\theta 4$		3°	

**PACKAGE DESIGNATOR**  
SOT-23-3L

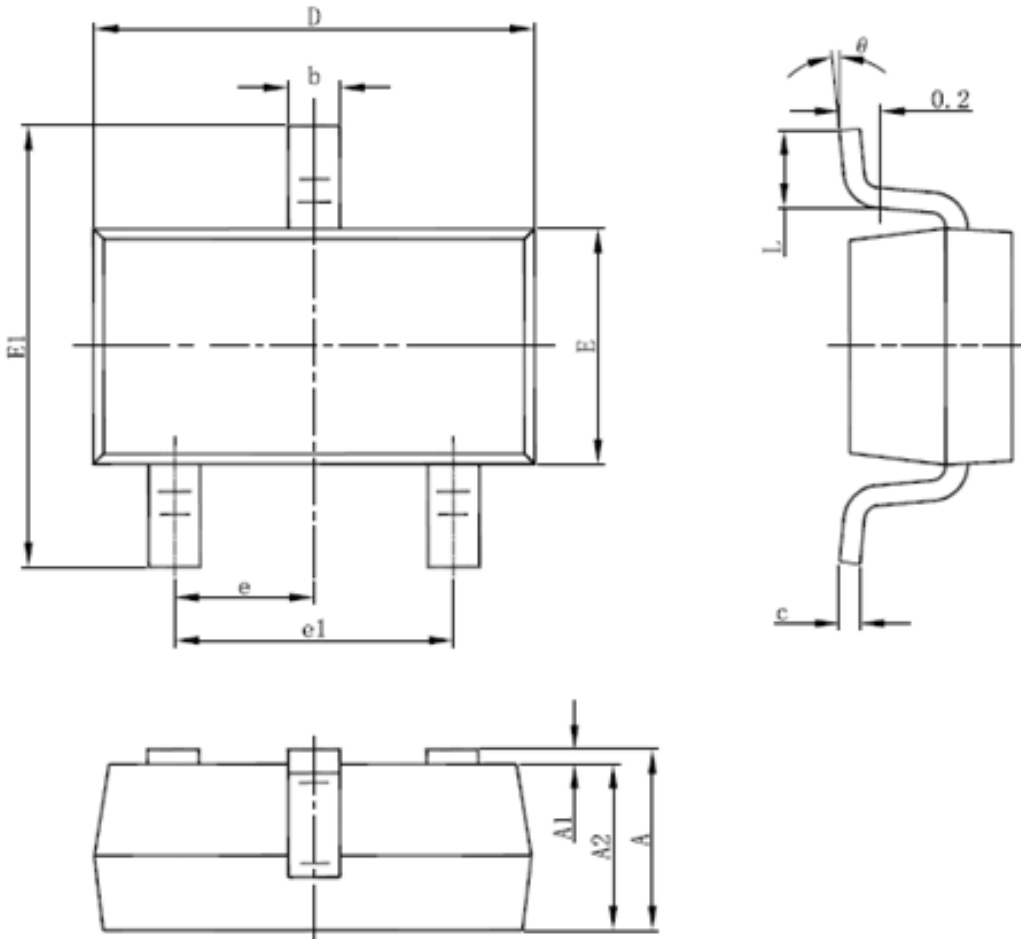





**Cosemitech**

**CH910/CH910L**

**Automotive Product Group**

This is advanced information on a new product now in development or undergoing evaluation. Details are subject to change without notice and Cosemitech assumes no obligation for future manufacture of this product. Contact Cosemitech for the latest status.

**Preliminary Datasheet 1.1**

Symbol	Dimensions In Millimeters		Dimensions In Inches	
	Min	Max	Min	Max
A	1.050	1.250	0.041	0.049
A1	0.000	0.100	0.000	0.004
A2	1.050	1.150	0.041	0.045
b	0.300	0.500	0.012	0.020
c	0.100	0.200	0.004	0.008
D	2.820	3.020	0.111	0.119
E	1.500	1.700	0.059	0.067
E1	2.650	2.950	0.104	0.116
e	0.950(BSC)		0.037(BSC)	
e1	1.800	2.000	0.071	0.079
L	0.300	0.600	0.012	0.024
$\theta$	0°	8°	0°	8°

Information furnished is believed to be accurate and reliable. However, Cosemitech assumes no responsibility for the consequences of use of such information nor for any infringement of patents or other rights of third parties which may result from its use. No license is granted by implication or otherwise under any patent or patent rights of Cosemitech. Specification mentioned in this publication are subject to change without notice. This publication supersedes and replaces all information previously supplied. Cosemitech products are not authorized for use as critical components in life support devices or systems without express written approval of Cosemitech.

The Cosemitech logo is a registered trademark of Cosemitech

单击下面可查看定价，库存，交付和生命周期等信息

[>>cosemitech\(意瑞半导体\)](#)