



SPECIFICATION

宏致電子股份有限公司

桃園縣中壢市東園路13號

No.13, Dongyuan Rd., Jhongli City,

Taoyuan County 320, Taiwan (R.O.C.)

TEL: +886-3-463-2808

FAX: +886-3-463-1800

SPEC. NO.: PS-51493-XXXXX-XXX REVISION: D

PRODUCT NAME: Tiny-X Series 0.8mm WTB CONN. SMT D/R S/T TYPE

PRODUCT NO: 51493-XXXXX-XXX
51494-XXXXX-XXX

PREPARED: CHEN CHUN YUAN DATE: 2019/12/10	CHECKED: TSO I CHIAO DATE: 2019/12/10	APPROVED: WANG CHUN SHENG DATE: 2019/12/10
--	--	---

2010/10/30 TR-FM-73015L



TITLE: 0.8 MM WTB CONN. SMT D/R S/T TYPE

RELEASE DATE: 2019/12/10

REVISION: D

ECN No: 1912266

PAGE: 2 OF 13

1	REVISION HISTORY	3
2	SCOPE.....	4
3	APPLICABLE DOCUMENTS	4
4	REQUIREMENTS	4
5	PERFORMANCE	5
6	INFRARED REFLOW CONDITION.....	7
7	PRODUCT QUALIFICATION AND TEST SEQUENCE.....	8
8	MATTING/UNMATTING FORCE	9
9	CABLE SIDE CONNECTOR ASSEMBLE SPECIFICATION.....	9
10	WIRE RETENTION FORCE	11
11	NOTES ON USING CONNECTOR	11



TITLE: 0.8 MM WTB CONN. SMT D/R S/T TYPE

RELEASE DATE: 2019/12/10

REVISION: D

ECN No: 1912266

PAGE: 3 OF 13

1 Revision History

Rev.	ECN #	Revision Description	Prepared	Date
A	1810286	FOR PDR APD1070290 NEW REV	CHEN CHUN YUAN	2018/10/25
B	1902080	Modify Terminal / Housing Retention Force (Rcpt. CONN.)	CHEN CHUN YUAN	2019/02/18
C	1905058	WIRE 11682->10064	CHEN CHUN YUAN	2019/05/21
D	19xxxx	WIRE RETENTION FORCE Parallel 0.5 -> 0.4 Kgf Min. ADD WIRE 11682	CHEN CHUN YUAN	2019/12/10

TITLE: **0.8 MM WTB CONN. SMT D/R S/T TYPE**

RELEASE DATE: 2019/12/10

REVISION: D

ECN No: 1912266

PAGE: **4** OF 13

2 SCOPE

This specification covers performance, tests and quality requirements for 0.8 mm WTB CONN.

3 APPLICABLE DOCUMENTS

EIA-364: ELECTRONICS INDUSTRIES ASSOCIATION

4 REQUIREMENTS

4.1 Design and Construction

- 4.1.1 Product shall be of design, construction and physical dimensions specified on applicable product drawing.
- 4.1.2 All materials conform to R.o.H.S. and the standard depends on TQ-WI-140101.

4.2 Materials and Finish

- 4.2.1 Contact: High performance copper alloy (**Phosphor Bronze**)
Finish: (a) Contact Area: **Refer to the drawing.**
(b) Under plate: **Refer to the drawing.**
(c) Solder area: **Refer to the drawing.**
- 4.2.2 Housing: Thermoplastic or Thermoplastic High Temp., UL94V-0
- 4.2.3 Fitting Nail: **Copper Alloy, Finish: Refer to the drawing.**

4.3 Ratings

- 4.3.1 Working Voltage Less than 36 Volts AC(Per Pin)
- 4.3.2 Voltage: **30 Volts AC/DC (per pin)**
- 4.3.3 Current: **1 Amperes (per pin)**
- 4.3.4 Operating Temperature : **-40°C to +80°C**

TITLE: 0.8 MM WTB CONN. SMT D/R S/T TYPE

RELEASE DATE: 2019/12/10

REVISION: D

ECN No: 1912266

PAGE: 5 OF 13

5 Performance

5.1. Test Requirements and Procedures Summary

Item	Requirement	Standard
Examination of Product	Product shall meet requirements of applicable product drawing and specification.	Visual, dimensional and functional per applicable quality inspection plan.
ELECTRICAL		
Item	Requirement	Standard
Low Level Contact Resistance	20 m Ω Max.(initial)per contact 20 m Ω Max.change allowed	Mate connectors, measure by dry circuit, 20mV Max., 10mA Max. (EIA-364-23)
Insulation Resistance	100 M Ω Min.	Unmated connectors, apply 250 V DC between adjacent terminals. (EIA-364-21)
Dielectric Withstanding Voltage	No discharge, flashover or breakdown. Current leakage: 1 mA max.	250 VAC Min. at sea level for 1 minute. Test between adjacent contacts of unmated connectors. (EIA-364-20)
Temperature rise	30°C Max. Change allowed	Mate connector: measure the temperature rise at rated current until temperature stable. The ambient condition is still air at 25°C (EIA-364-70,METHOD1,CONDITION1)
MECHANICAL		
Item	Requirement	Standard
Durability	10 cycles.	The sample should be mounted in the tester and fully mated and unmated the number of cycles specified at the rate of 25.4 ± 3mm/min. (EIA-364-09)
Mating/Unmating Forces	See heading 8	Operation Speed : 10 ± 3 mm/minute.. Measure the force required to mate/unmate connector. (EIA-364-13)
Terminal / Housing Retention Force (Rcpt. CONN.)	0.1 kgf MIN.	Apply axial pull out force at the speed rate of 10 ± 3 mm/minute. On the terminal assembled in the housing.

TITLE: 0.8 MM WTB CONN. SMT D/R S/T TYPE

RELEASE DATE: 2019/12/10

REVISION: D

ECN No: 1912266

PAGE: 6 OF 13

<p>Vibration</p>	<p>1 μs Max.</p>	<p>The electrical load condition shall be 100 mA maximum for all contacts. Subject to a simple harmonic motion having amplitude of 0.76mm (1.52mm maximum total excursion) in frequency between the limits of 10 and 55 Hz. The entire frequency range, from 10 to 55 Hz and return to 10 Hz, shall be traversed in approximately 1 minute. This motion shall be applied for 2 hours in each of three mutually perpendicular directions. (EIA-364-28 Condition I)</p>
<p>Shock (Mechanical)</p>	<p>1 μs Max.</p>	<p>Subject mated connectors to 50 G's (peak value) half-sine shock pulses of 11 milliseconds duration. Three shocks in each direction shall be applied along the three mutually perpendicular axes of the test specimen (18 shocks). The electrical load condition shall be 100mA maximum for all contacts. (EIA-364-27, test condition A)</p>

ENVIRONMENTAL

Item	Requirement	Standard
<p>Resistance to Reflow Soldering Heat</p>	<p>See Product Qualification and Test (Lead Free)</p>	<p>Pre Heat : 150°C~180°C, 60~120 sec. Heat : 230°C Min., 40 sec Min. Peak Temp. : 260°C Max, 10 sec Max.</p>
<p>Thermal Shock</p>	<p>See Product Qualification and Test Sequence Group 4</p>	<p>Mate module and subject to follow condition for 10 cycles. 1 cycles: -55 +0/-3 °C, 30 minutes +85 +3/-0 °C, 30 minutes (EIA-364-32, test condition I)</p>
<p>Humidity</p>	<p>See Product Qualification and Test Sequence Group 4</p>	<p>Mated Connector 40°C, 90~95% RH, 96 hours. (EIA-364-31,Condition A, Method II)</p>
<p>Temperature life</p>	<p>See Product Qualification and Test Sequence Group 5</p>	<p>Subject mated connectors to temperature life at 85°C for 96 hours. (EIA-364-17, Test condition A)</p>

TITLE: 0.8 MM WTB CONN. SMT D/R S/T TYPE

RELEASE DATE: 2019/12/10

REVISION: D

ECN No: 1912266

PAGE: 7 OF 13

Salt Spray (Only For Gold Plating)	See Product Qualification and Test Sequence Group 6	Subject mated/unmated connectors to 5% salt-solution concentration, 35°C (I) Gold flash for 8 hours (II) Gold plating 3 u" for 48 hours. (EIA-364-26)
Solder ability	Tin plating: Solder able area shall have minimum of 95% solder coverage. Gold plating: Solder able area shall have minimum of 75% solder coverage	And then into solder bath, Temperature at 245 ±5°C, for 4-5 sec. (EIA-364-52)
Hand Soldering Temperature Resistance	Appearance: No damage	T ≥ 350°C, 3sec at least.

Note. Flowing Mixed Gas shall be conduct by customer request.

6 INFRARED REFLOW CONDITION

6.1. Lead-Free Process

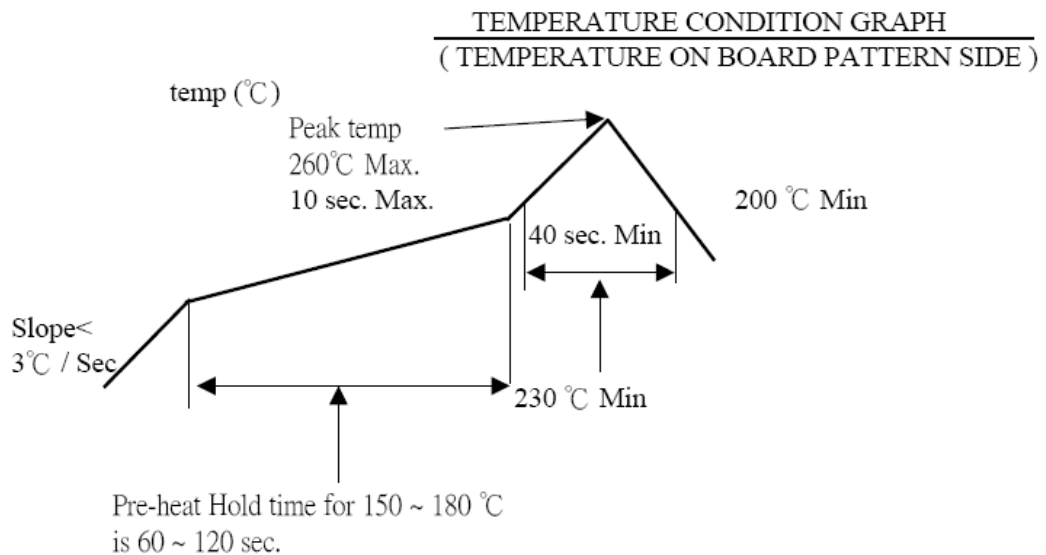

TITLE: 0.8 MM WTB CONN. SMT D/R S/T TYPE

RELEASE DATE: 2019/12/10

REVISION: D

ECN No: 1912266

PAGE: 8 OF 13

7 PRODUCT QUALIFICATION AND TEST SEQUENCE

Test or Examination	Test Group									
	1	2	3	4	5	6	7	8	9	
	Test Sequence									
Examination of Product	1,3	1	1	1、7	1、6	1、4			1,3	
Low Level Contact Resistance		2、6	2、5	2、8	2、7	2、5				
Insulation Resistance				3、9	3、8					
Dielectric Withstanding Voltage				4、10	4、9					
Temperature rise	2									
Mating / Unmating Forces		3、5								
Durability		4								
Vibration			3							
Shock (Mechanical)			4							
Thermal Shock				5						
Humidity				6						
Temperature life					5					
Salt Spray(Only For Gold Plating)						3				
Solder ability							1			
Terminal / Housing Retention Force (Rcpt. CONN.)								1		
Hand Soldering Temperature Resistance									2	
Sample Size	2	4	4	4	4	4	2	4	4	

TITLE: 0.8 MM WTB CONN. SMT D/R S/T TYPE

RELEASE DATE: 2019/12/10

REVISION: D

ECN No: 1912266

PAGE: 9 OF 13

8 MATTING/UNMATTING FORCE

Unit : N/Kg

Number of circuits	Mating force N/Kg Max.		Unmating force N/Kg Min.			
	initial		initial		10 th	
	N	Kg	N	Kg	N	Kg
2	14.7	1.5	1.76	0.18	0.98	0.1
4	17.6	1.8	2.74	0.28	1.96	0.2
6	19.6	2.0	3.72	0.38	2.94	0.3

9 CABLE SIDE CONNECTOR ASSEMBLE SPECIFICATION

9.1 FEATURES OF CONNECTOR

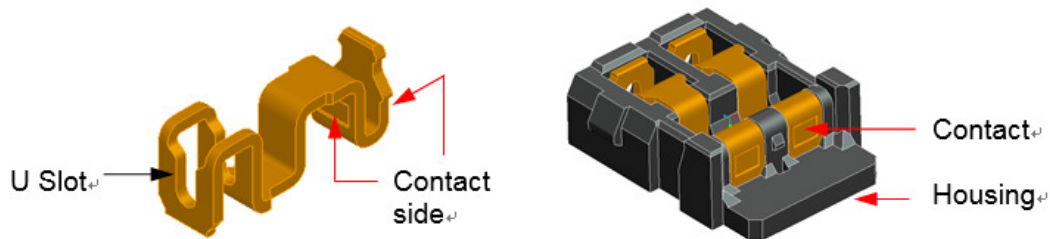

9.2 ASSEMBLY PROCESS

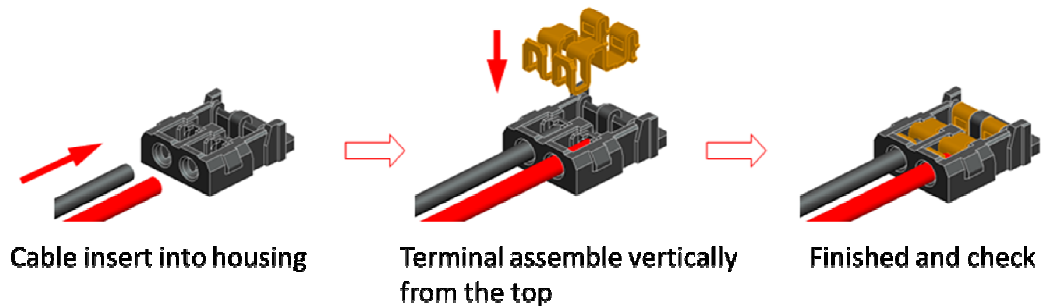

9.3 CABLE ASSEMBLY CRITERIA

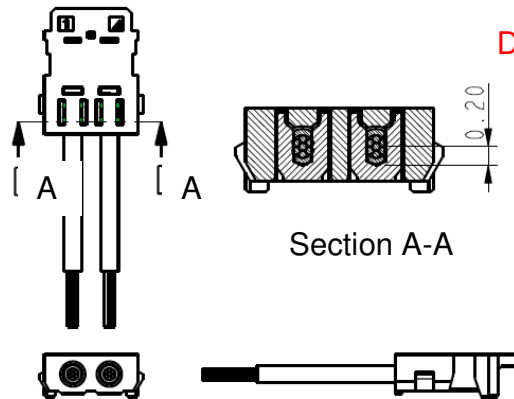

Applicable Wire		Depth Dimension D
Insulation O.D.	0.39+/-0.01	0.20+/-0.03
Note: Terminal assemble depth please refer to dimensions "D" .		

9.4 PRECAUTION TO HANDLING

1. wire position must be alignment
2. recommended the fixture tool have a support area to hold the terminal while its assembled.
3. contact position must be align or under the top of housing.

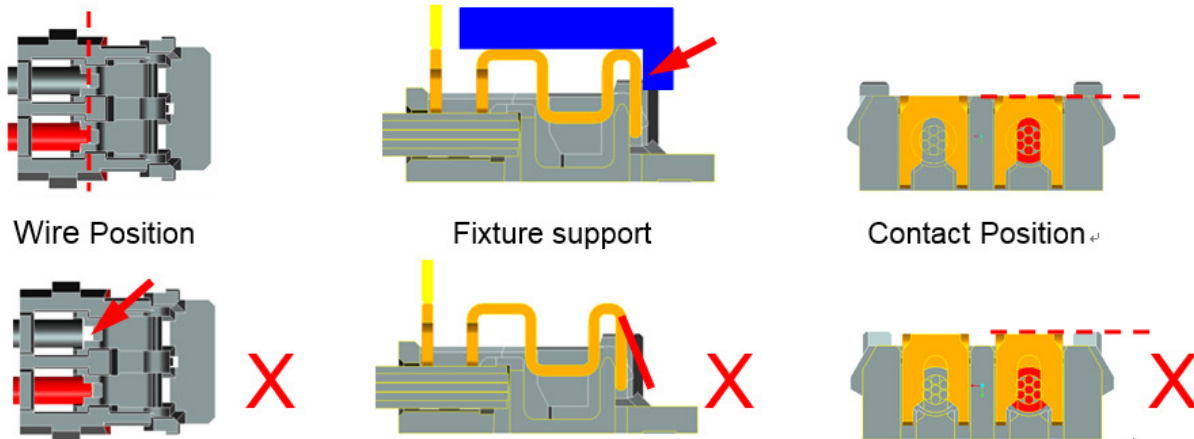

TITLE: 0.8 MM WTb CONN. SMT D/R S/T TYPE

RELEASE DATE: 2019/12/10

REVISION: D

ECN No: 1912266

PAGE: 11 OF 13

10 WIRE RETENTION FORCE

Wire size	UL style	Insulation (mm)	Material of Insulation	Parallel	Perpendicular
AWG#32 /7C	UL 10064 or UL 11682	0.39+/-0.01	PPE / PE	0.4 Kgf Min.	0.4 Kgf Min.

Note : If need retention force more that must use the UV glue

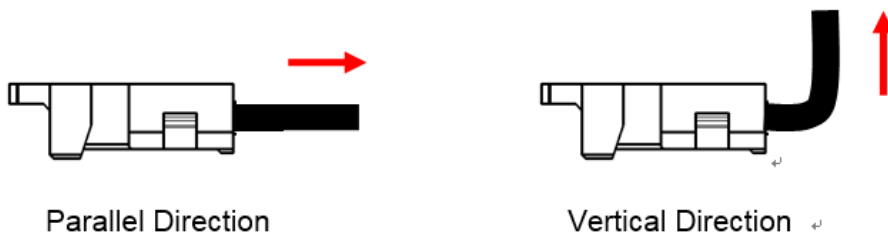

11 NOTES ON USING CONNECTOR

11.1 MATING CONNECTOR PROCEDURES

Step 1 Alignment and checking position

Align the plug connector and receptacle connector positions and check the position does not crooked before connecting.

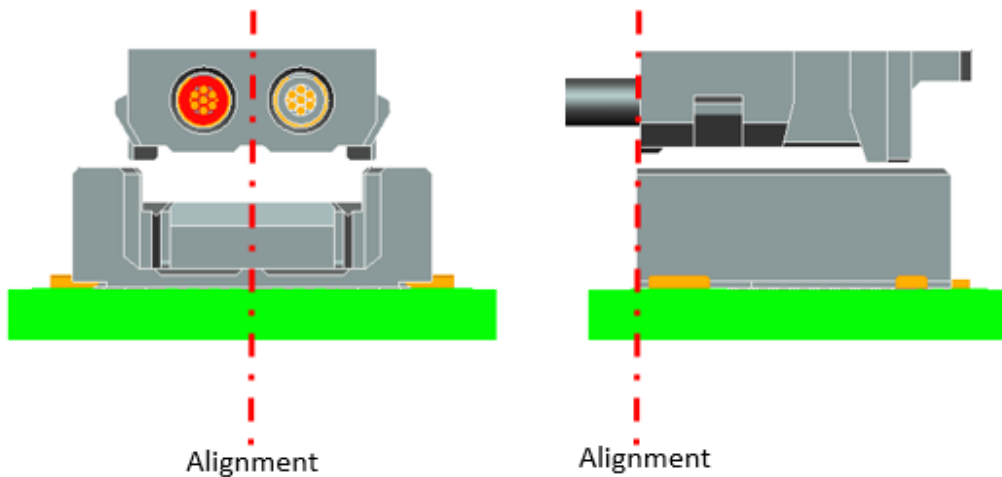

Step 2 Push and check position

Push the top surface of connector until its fully mated , check the top surface has been alignment and make sure the lock into the slot .

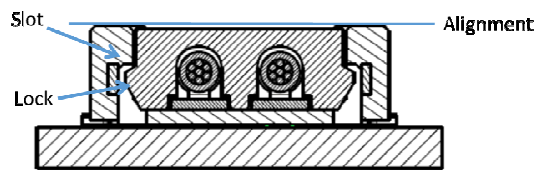

11.2 UNMATING CONNECTOR PROCEDURES

11.2.1 UNMATING BY HAND

Pull up cable connector from the tip side to unmate the connector

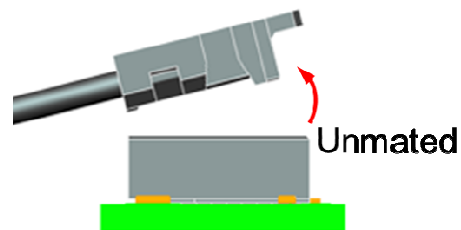
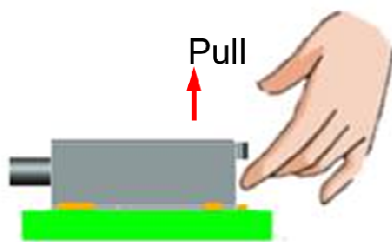

11.2.2 USE THE TOOL

Please use tool to release plug connector as shown below while it is in an extremely limited space application

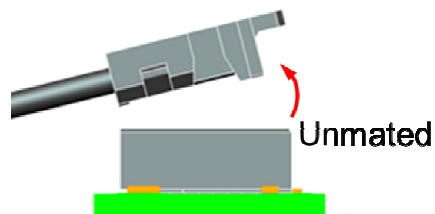
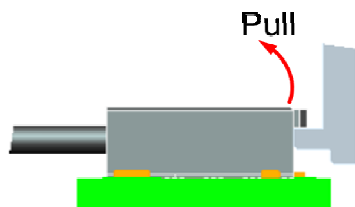

TITLE: 0.8 MM WTB CONN. SMT D/R S/T TYPE

RELEASE DATE: 2019/12/10

REVISION: D

ECN No: 1912266

PAGE: 13 OF 13

11.2.3 RECOMMENDED RELEASE TOOL DIMENSIONS

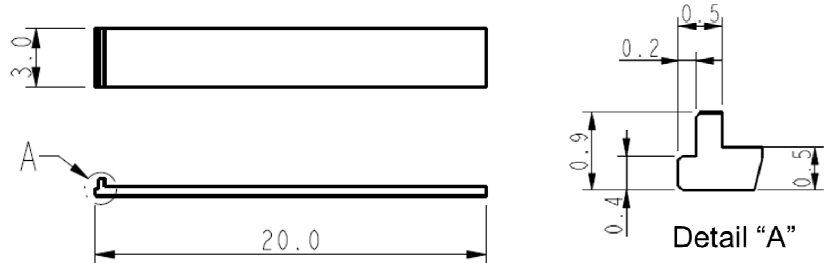

11.3 PRECAUTION TO HANDLING

Strongly pressed and tilted insert is forbidden, it may cause connector damage.

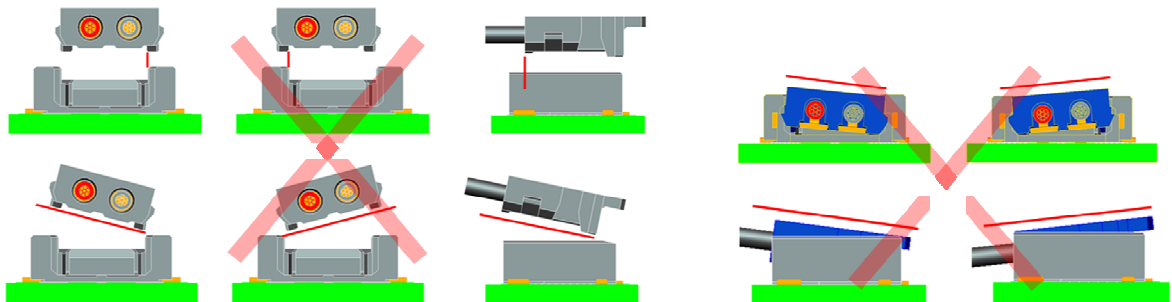

单击下面可查看定价，库存，交付和生命周期等信息

[>>ACES\(宏致\)](#)