



**Anti-Sulfurated Thick Film
Chip Resistor Arrays
(CNS Series Standard)
Halogen-Free
AEC-Q200 qualified**

Document No.	TCNS-XX0S001C
Revise Date	2021/01/25
page number	1 / 11

1. Scope :

This specification applies for the CNS series of Anti-Sulfurated thick film chip resistor arrays by TA-I.

2. Construction , Dimensions , Schematic :

2.1 Construction :

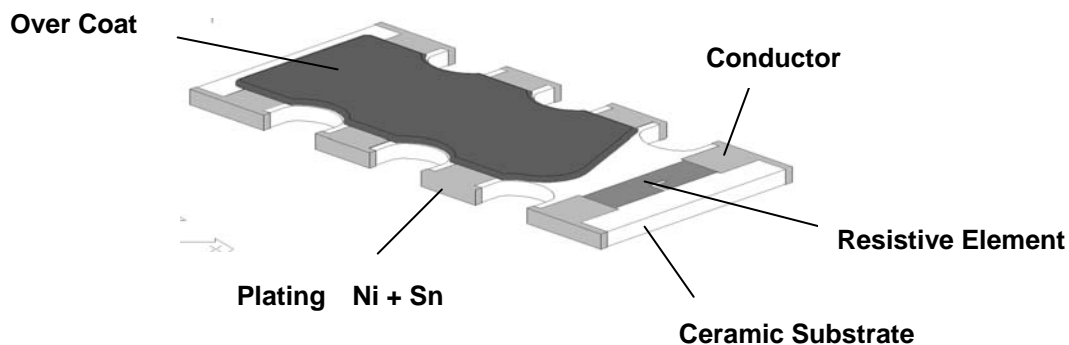

2.1.1 Chip Resistor Arrays :

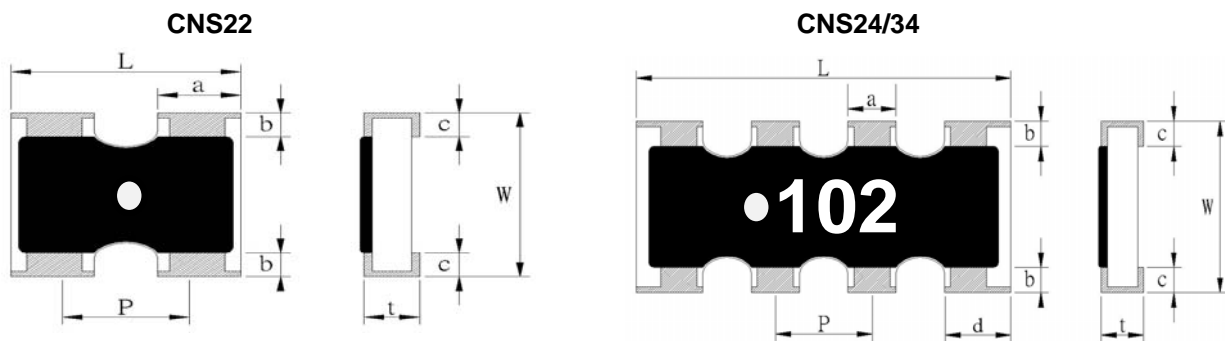

UNIT: mm

Type	L	W	t	P	a	b	c	d
CNS22	1.0 ± 0.1	1.0 ± 0.1	0.35 ± 0.1	0.65 ± 0.1	0.33 ± 0.1	0.15 ± 0.1	0.25 ± 0.1	0.33±0.1
CNS24	2.0 ± 0.1	1.0 ± 0.1	0.4 ± 0.1	0.5 ± 0.05	0.3 ± 0.1	0.15 ± 0.1	0.25 ± 0.1	0.4±0.1
CNS34	3.2 ± 0.2	1.6 ± 0.15	0.5 ± 0.1	0.8 ± 0.05	0.45 ± 0.1	0.3 ± 0.2	0.3 ± 0.2	0.6±0.1



**Anti-Sulfurated Thick Film
Chip Resistor Arrays
(CNS Series Standard)
Halogen-Free
AEC-Q200 qualified**

Document No.	TCNS-XX0S001C
Revise Date	2021/01/25
page number	2 / 11

2.3 Schematic :

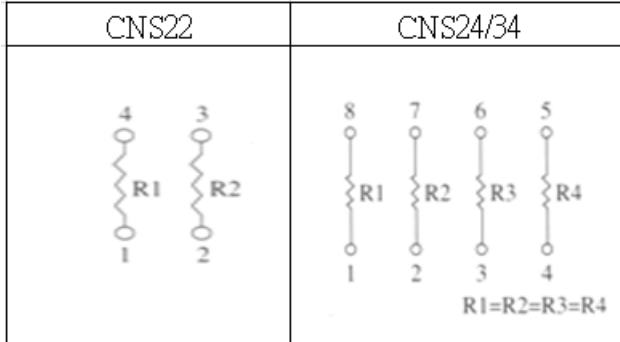

3. Type Designation:

3.1 Chip Resistor Arrays

CNS

34

J

T

103

Product Code

size

Tolerance

Packaging

Nominal
Resistance

CNS : Anti-Sulfurated

Chip Resistor Array

Power Rating

22-0402*2
24-0402*4
34-0603*4

J-±5%
G-±2%
F-±1%

T- Paper Tape

3 digits E.G.:
(E-24) 103 = 10KΩ
5R6 = 5.6Ω
4 digits E.G. :
(E-96) 1540 = 154Ω
43R2 = 43.2Ω



**Anti-Sulfurated Thick Film
Chip Resistor Arrays
(CNS Series Standard)
Halogen-Free
AEC-Q200 qualified**

Document No.	TCNS-XX0S001C
Revise Date	2021/01/25
page number	3 / 11

4. Ratings & Characteristics :

Type	Power Rating at 70°C	Rating Voltage	Max. Working Voltage	Max. Over Load Voltage	Operating Temp. (°C)	Resistance Tolerance (%)	Resistance Range (Ω)	Temp Co-efficient PPM/°C
CNS22	1/16W	Refer 4.2	25V	50V	-55 ↓ +125°C	±5% ±2% ±1%	10Ω~1MΩ	±250
CNS24							10Ω~1MΩ	±200
CNS34			50V	100V		±5%	3.0Ω~9.1Ω	±400
CNS34			50V	100V				
CNS22			25V	50V		±5%	3.0Ω~9.1Ω	±500
CNS24			25V	50V				

0Ω THICK FILE CHIP RESISTOR ARRAYS			
Type	Rate Current	Max Overload Current	Resistance Range
CNS Series	1A	2.5A	50mΩ MAX

4.1 Derating Curve :

For resistors operated at ambient temperature over 70°C , power rating shall be derated in accordance with figure 1.

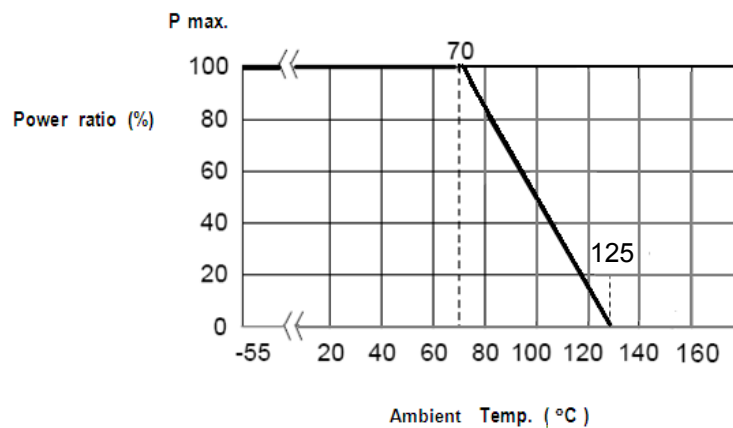

Figure 1

4.2 Rated Voltage:

The rated voltage is calculated by the following formula:

$$E = \sqrt{P * R}$$

E=Rated Voltage(V)
P=Rated Power(W)
R=Resistance Value(Ω)

E.G. : What is CNS34JT102 the rated voltage ?

CNS34JT102 P:1/16W ; R:102 = 1KΩ = 1000Ω

$$E = \sqrt{0.0625(W) * 1000(\Omega)} = 7.9 (V)$$



**Anti-Sulfurated Thick Film
Chip Resistor Arrays
(CNS Series Standard)
Halogen-Free
AEC-Q200 qualified**

Document No.	TCNS-XX0S001C
Revise Date	2021/01/25
page number	4 / 11

5. Reliability Tests:

Test Items	Reference standard	Condition of Test	Test Limits ΔR
Temperature Coefficient of Resistance	IEC 60115-1 4.8	-At +25/-55 °C and +25/+125 °C	Refer 5.0
Short Time Overload	IEC60115-1 4.13	2.5 X rated voltage for 5 sec	$\pm(2.0\%+0.1\Omega)$ 0 Ω : 50 m Ω or less
High Temperature Exposure (Storage)	AEC-Q200-REV D-Test 3 MIL-STD-202 Method 108	1000 hrs. @ T=125°C. Unpowered. Measurement at 24 \pm 2 hours after test conclusion.	0.5%, 1%: $\pm(1.0\%+0.05\Omega)$ 2%, 5%: $\pm(2.0\%+0.1\Omega)$ 0 Ω : 50m Ω or less
Temperature Cycling	AEC-Q200-REV D-Test 4 JESD22 Method JA-104	1000 Cycles (-55°Cto+125°C) Measurement at 24 \pm 4 hours after test conclusion. 30min maximum dwell time at each temperature extreme. 1 min. maximum transition time.	$\pm(2\% + 0.1\Omega)$ 0 Ω : 50m Ω or less
Moisture Resistance	AEC-Q200-REV D-Test 6 MIL-STD-202 Method 106	T=24 hours / Cycle, 10 Cycles. Notes : Steps 7a& 7b not required. Unpowered.	$\pm(2.0\%+0.1\Omega)$ 0 Ω : 50m Ω or less
Biased Humidity	AEC-Q200-REV D-Test 7 MIL-STD-202 Method 103	1000 hours 85°C/85%RH. Note: Specified conditions: 10% of operating power (not exceeding max working voltage). Measurement at 24 \pm 2 hours after test conclusion.	$\pm(3\% + 0.1\Omega)$ 0 Ω : 100m Ω or less
Operational Life	AEC-Q200-REV D-Test 8 MIL-STD-202 Method 108	1000 hours TA=125°C at 35% rated power. Measurement at 24 \pm 4 hours after test conclusion.	$\pm(3\% + 0.1\Omega)$ 0 Ω : 100m Ω or less
External Visual	AEC-Q200-REV D-Test 9 MIL-STD-883 Method 2009	Electrical test not required. Inspect device construction, marking and workmanship.	
Physical Dimension	AEC-Q200-REV D-Test 10 JESD22 Method JB-100	Verify physical dimensions to the applicable device detail specification. Note: User(s) and Suppliers spec. Electrical test not required.	
Resistance to Solvents	AEC-Q200-REV D-Test 12 MIL-STD-202 Method 215	a:Isopropyl Alcohol : Mineral Spirits= 1 : 3 b:Terpene Defluxer (Bioact EC-7R) c:Deionized water : Propylene Glycol Monomethyl Ether : monoethanolamine = 42 : 1 : 1	Marking and protective layer can not be detached
Mechanical Shock	AEC-Q200-REV D-Test 13 MIL-STD-202 Method 213	Wave Form : Tolerance for half sine shock pulse. Peak value is 100g's. Normal duration(D) is 6(ms)	$\pm(1\% + 0.1\Omega)$ 0 Ω : 50m Ω or less
Vibration	AEC-Q200-REV D-Test 14 MIL-STD-202 Method 204	5 g's for 20 min., 12 cycles each of 3 orientations. Note: Test from 10-2000 Hz.	$\pm(1\% + 0.1\Omega)$ 0 Ω : 50m Ω or less



**Anti-Sulfurated Thick Film
Chip Resistor Arrays
(CNS Series Standard)
Halogen-Free
AEC-Q200 qualified**

Document No.	TCNS-XX0S001C
Revise Date	2021/01/25
page number	5 / 11

Resistance to Soldering Heat	AEC-Q200-REV D-Test 15 MIL-STD-202 Method 210	Condition B : Immerse the specimens in and eutectic solder at 260±5°C for 10±1S .	±(1% + 0.1 Ω) 0 Ω : 50mΩ or less
Thermal Shock	AEC-Q200-REV D-Test 16 MIL-STD-202 Method 107	-55°C/+155°C. Note: Number of cycles required-300, Maximum transfer time-20 seconds, Dwell time-15 minutes. Air-Air.	±(1% + 0.1 Ω) 0 Ω : 50mΩ or less
ESD	AEC-Q200-REV D-Test 17	verify the voltage setting at 500V	±(2% + 0.1 Ω)
Solderability	AEC-Q200-REV D-Test 18 J-STD-002	Method B, aging 4 hours at 155 °C dry heat Lead-free solder bath at 235±3 °C Dipping time: 3±0.5 seconds	> 95% area covered with tin
Flammability	AEC-Q200-REV D-Test 20 UL-94	V-0 or V-1 are acceptable. Electrical test not required.	V-0 or V-1
Board Flex (Bending)	AEC-Q200-REV D-Test 21	The duration of the applied forces shall be 60 (+ 5) Sec 3mm deflection	±(1% + 0.1 Ω) 0 Ω : 50mΩ or less
Terminal Strength (SMD)	AEC-Q200-REV D-Test 22	Force of 1.8kg for 60 seconds	±(1% + 0.05 Ω) 0 Ω : 50mΩ or less
Sulfuration Test	ASTM-B-809-95	Sulfur (Sulfur Vapor) 1,000 hours, 105±2°C, unpowered	0.5%, 1%:±(1%+0.05 Ω) 2%, 5%:±(2%+0.05 Ω) 0 Ω : 100mΩ or less

Note* : RCWV : Rated continuous working voltage .



**Anti-Sulfurated Thick Film
Chip Resistor Arrays
(CNS Series Standard)
Halogen-Free
AEC-Q200 qualified**

Document No.	TCNS-XX0S001C
Revise Date	2021/01/25
page number	6 / 11

6. Marking

6.1 $\pm 2\%$ & $\pm 5\%$ (E24) : CNS24 / 34

Resistance value is expressed by 3 digits, the first two digits represent the significant figures of nominal resistance value in Ω , and the third digit represents exponent for base of 10.

E.G. $472 = 47 \times 10^2 = 4700 \Omega = 4.7K \Omega$

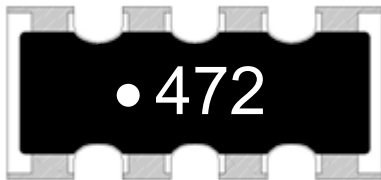

6.2 $\pm 1\%$ (E96) : CNS24 / 34

Resistance value is expressed by 4 digits, the first three digits represent the significant figures of nominal resistance value in Ω , and the fourth digit represents exponent for base of 10.

E.G. $4701 = 470 \times 10^1 = 4700 \Omega = 4.7k \Omega$

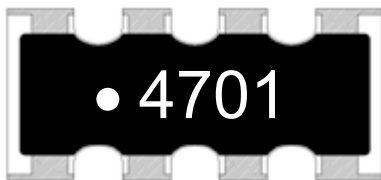

6.3 CNS24 / 34

E.G. : $0 = 0 \Omega$

6.4 CNS22 :

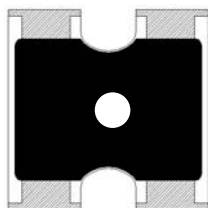



**Anti-Sulfurated Thick Film
Chip Resistor Arrays
(CNS Series Standard)
Halogen-Free
AEC-Q200 qualified**

Document No.	TCNS-XX0S001C
Revise Date	2021/01/25
page number	7 / 11

7. Taping & Reel

7.1 Taping Dimensions

7.1.1 2 mm pitch paper

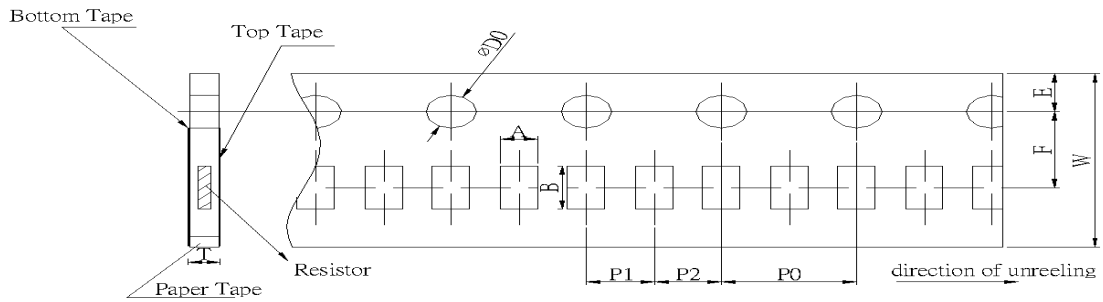

UNIT: mm

Type	A	B	W	F	E	P1	P2	P0	$\phi D0$	T0
CNS22	1.2±0.15	1.2±0.1	8.0±0.2	3.5±0.05	1.75±0.1	2.0±0.1	2.0±0.05	4.0±0.1	+0.1	0.45±0.1
CNS24		2.2±0.2							-0	0.64±0.1

7.1.2 4 mm pitch paper

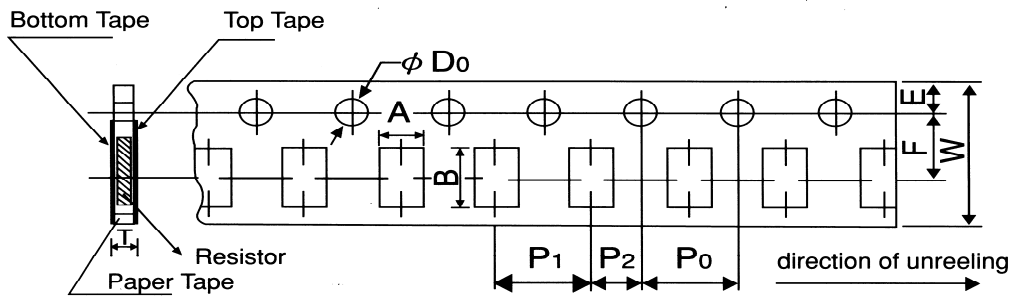

UNIT: mm

Type	A	B	W	F	E	P1	P2	P0	$\phi D0$	T
CNS34	2.0±0.15	3.6±0.2	8.0±0.2	3.5±0.05	1.75±0.1	4.0±0.1	2.0±0.05	4.0±0.1	+0.1 -0	0.84±0.1



**Anti-Sulfurated Thick Film
Chip Resistor Arrays
(CNS Series Standard)
Halogen-Free
AEC-Q200 qualified**

Document No.	TCNS-XX0S001C
Revise Date	2021/01/25
page number	8 / 11

Package Type	Paper Tape	
	4 mm pitch	2 mm pitch
	178mm/R	178mm/R
CNS22		10000
CNS24		10000
CNS34	5000	

7.2 Reel Specifications

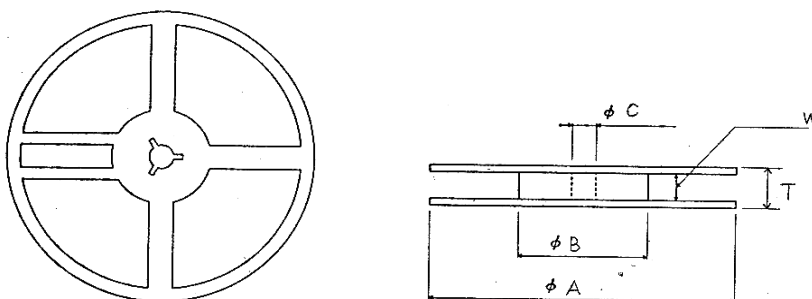

UNIT: mm

Type	ϕA	ϕB	ϕC	W	T
CNS22/24/34	178.0 ± 2.0	60.0 ± 1.0	13.0 ± 1.0	9.0 ± 1.0	11.5 ± 1.0

7.3 Peel off Strength:

Peel –off force of paper and blister tape is in accordance with “JIS-C5202” that is , 0.1 to 0.7 N at a peel-off speed of 300 mm / minute.

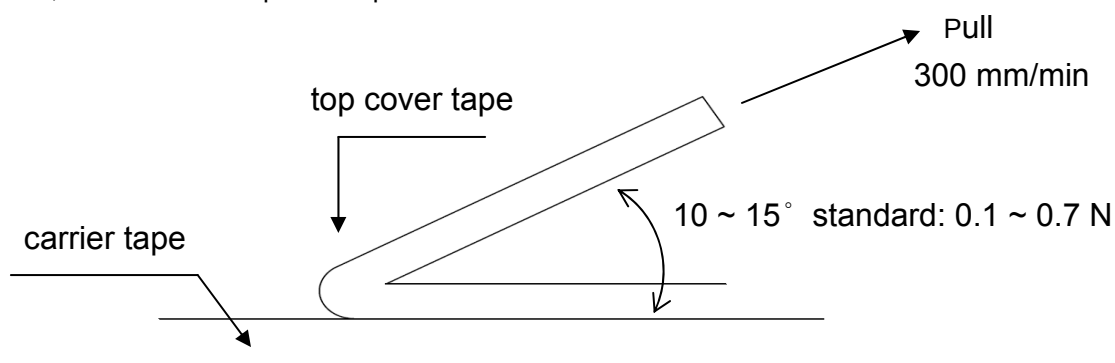



**Anti-Sulfurated Thick Film
Chip Resistor Arrays
(CNS Series Standard)
Halogen-Free
AEC-Q200 qualified**

Document No.	TCNS-XX0S001C
Revise Date	2021/01/25
page number	9 / 11

8. Label

8.1 Manufacture Label :

8.1.1 Chip Resistor Array :

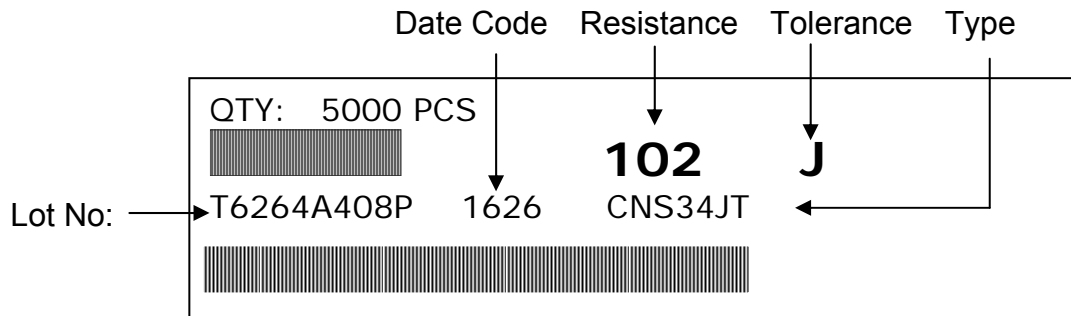

8.2. Customer Label (By customer request) :

8.2.1 Chip Resistor Array :

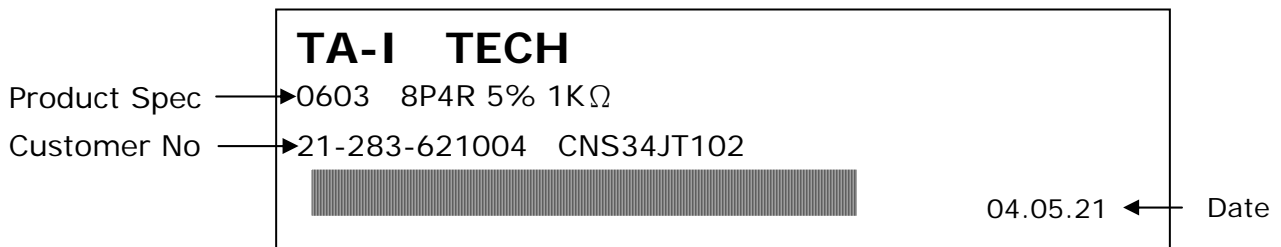

9. Recommended land patterns :

9.1 CNS22, CNS34

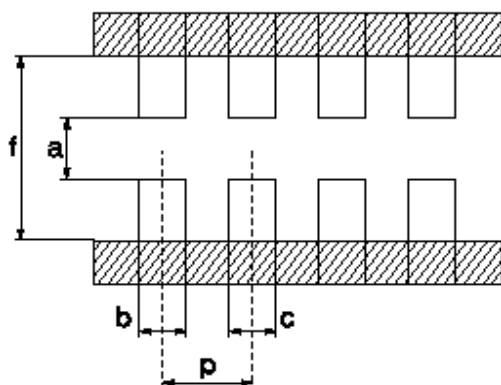

Land pattern		Dimension (mm)				
Type	Size	a	b	c	p	f
CNS	22	0.5	0.35~0.4	0.35~0.4	0.65	1.4~1.5
CNS	34	0.7~0.9	0.4~0.5	0.4~0.5	0.8	2.2~2.6



**Anti-Sulfurated Thick Film
Chip Resistor Arrays
(CNS Series Standard)
Halogen-Free
AEC-Q200 qualified**

Document No.	TCNS-XX0S001C
Revise Date	2021/01/25
page number	10 / 11

9.2 CNS24

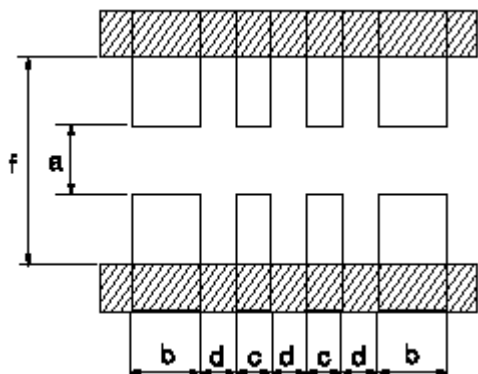

Type	Size	Land pattern				
		Dimension (mm)				
		a	b	c	d	f
CNS	24	0.4	0.525	0.25	0.25	1.4

10. Recommend IR – Reflow profile : (solder : Sn96.5 / Ag3 / Cu0.5)

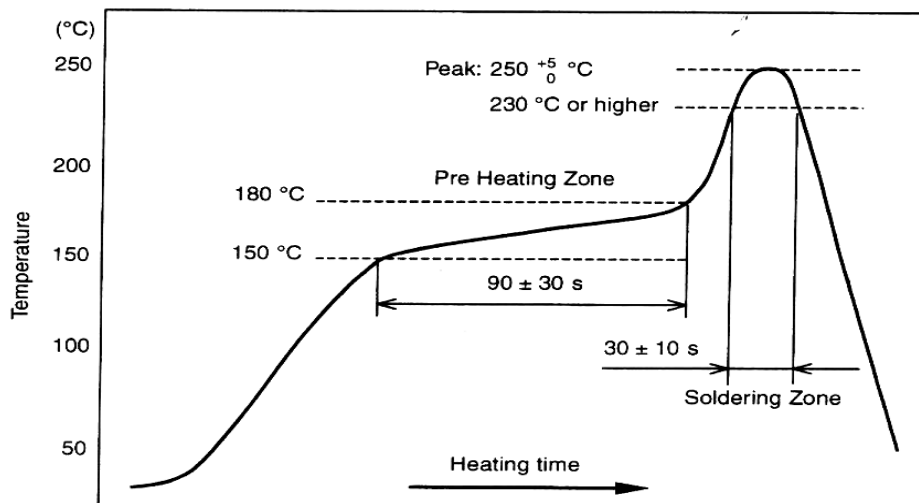

Peak : 250 ⁺⁵/₋₀ °C , 5 sec
 Pre – heat Zone : 150 to 180 °C , 90 ± 30 sec
 Soldering Zone : 230°C or higher , 30 ± 10 sec



**Anti-Sulfurated Thick Film
Chip Resistor Arrays
(CNS Series Standard)
Halogen-Free
AEC-Q200 qualified**

Document No.	TCNS-XX0S001C
Revise Date	2021/01/25
page number	11 / 11

11. Storage Conditions:

Temperature : 5 to 35 °C

Related Humidity : 40 to 75% RH

12. Shelf Life :

2 Years from manufacturing date.

13. ECN :

Engineering Change Notice: The customer will be informed with ECN if there is significant modification on the characteristics and materials described in Approval Sheet.

14. Manufacturing Country & City :

TA-I TECHNOLOGY CO., LTD. (Taiwan– Tao Yuan)

Tel: 886-3-3246169 Fax : 886-3-3246167

Associated companies :

(1) FORTUNE TASK RESISTOR FACTORY (China – Dongguan)

Tel : 86-769-8339-4790~3 Fax : 86-769-8339-4794

(2) TA-I TECHNOLOGY (DONGGUAN) CO., LTD. (China –Dongguan)

Tel : 86-769-8339-4790~3 Fax : 86-769-8339-4794

(3) TA-I TECHNOLOGY (SU ZHOU) CO., LTD. (China – Su Zhou)

Tel :86- 512-63457879 Fax : 86-512-63457869

(4) TAI OHM ELECTRONICS (M) SDN. BHD. (Malaysia – Penang)

Tel :604- 3900480 Fax : 604-3901481

(5) P.T.TAI ELECTRONICS Indonesia (Indonesia – Jakarta)

Tel : 62-21-89830123 Fax : 62-21-89830703

单击下面可查看定价，库存，交付和生命周期等信息

[>>TA-I\(大毅\)](#)