

FEATURES

- ※Ultra-low profile with 2.0mm
- ※Sharp detection feeling

APPLICATION

- ※Detection of car audio mechanism
- ※Smoke detector
- ※Notebook

SPECIFICATION

Contact Rating	1mA, 5V DC
Contact Resistance	1Ω max.
Insulation Resistance	100MΩ min. 100V DC
Dielectric Strength	100V AC/1 minute
Operating Force	105gf max.
Travel	2.0mm
Operating Life	100,000 cycles
Operating Temp.	-10°C ~ +60°C
Storage Temp.	-40°C ~ +85°C

HOW TO ORDER

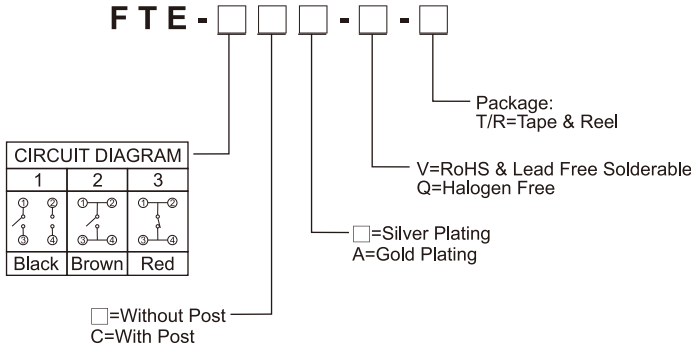

CIRCUIT

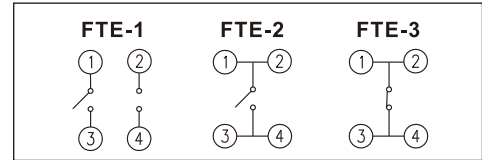

PACKAGE

<Tape & Reel>
3000 pcs

FTE-1C

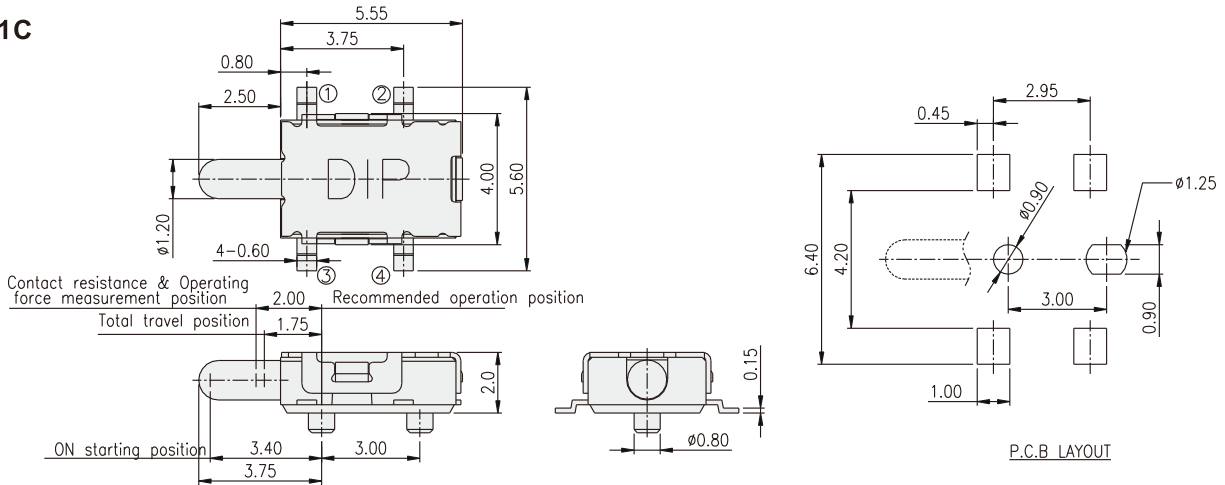

FTE-2

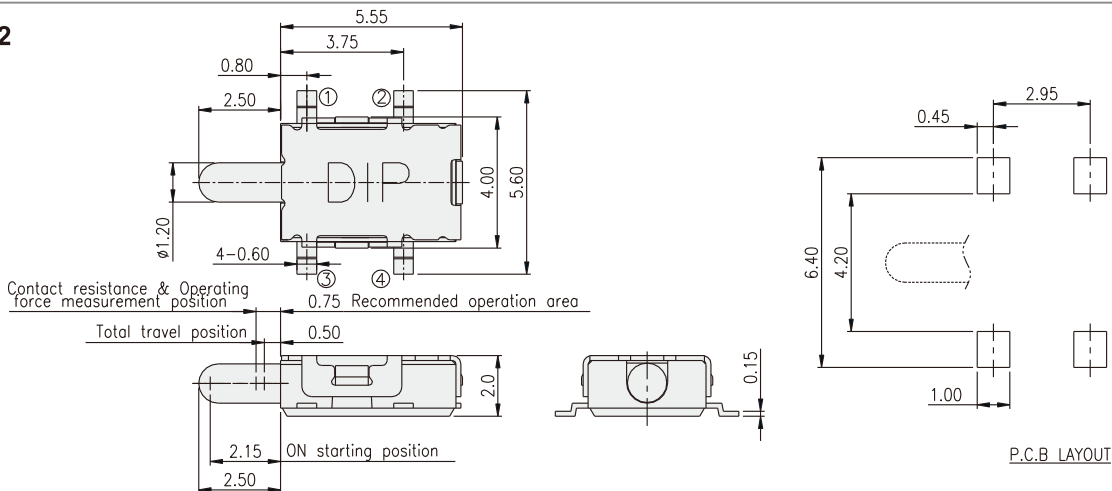

FTE-3C

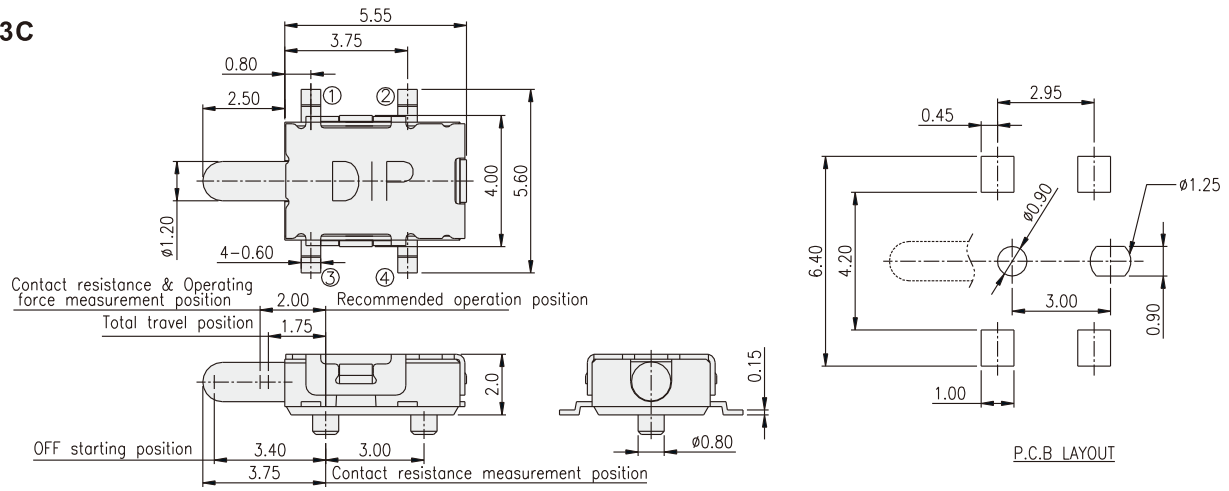

单击下面可查看定价，库存，交付和生命周期等信息

[>>Diptronics\(圆达\)](#)