

EL 2319 CH2319-C07001H-AM

Preliminary

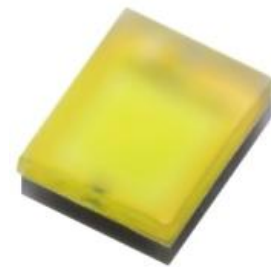

Features

- Package: White LEDs on Ceramic substrate
- Typ. Color Temperature: 5180 K ~ 6680 K
- Typ. Luminous Flux: 250 lm @ 700mA
- Viewing angle: Cold White 140°
- ESD: up to 8KV
- MSL : 1
- Preconditioning : According to JEDEC J-STD 020D Level 1
- Qualifications: According to AEC-Q101
- Compliance with RoHS and REACH

Applications

- Automotive Exterior Lighting , Day Time Running Light (DRL), Tail Light

Contents

1. Characteristics.....	3
2. Absolute Maximum Ratings.....	4
3. Characteristics Graph.....	5
4. Binning Information.....	10
5. Part Number	14
6. Ordering Information.....	15
7. Mechanical Dimension	16
8. Recommended Soldering Pad	17
9. Reflow Soldering Profile.....	17
10. Packaging Information	18
11. Handling of Silicon Resin for LEDs	20
12. Precaution for Use	21

1. Characteristics

Parameter	Symbol	Min.	Typ.	Max.	Unit	Condition
Forward Current	I_F	50	700	1000	mA	---
Luminous Flux ^{[1][2][3]}	Φ_v	225	250	325	lm	$I_F=700\text{mA}$
Forward Voltage ^{[4][5]}	V_F	2.75	3.25	4.00	V	$I_F=700\text{mA}$
Viewing Angle	φ	---	140	---	deg	$I_F=700\text{mA}$
Correlated Color Temperature	K	5180	5850	6680	K	$I_F=700\text{mA}$
Thermal Resistance (Junction to Solder)	Real	$R_{th JS real}$	---	3.99	---	K/W $I_F=700\text{mA}$
	Electrical	$R_{th JS el}$	---	4.70	---	

Notes:

1. Luminous Flux measurement tolerance: $\pm 8\%$.
2. The data of Luminous Flux measured at thermal pad=25°C
3. Typical luminous flux or light output performance is operated within the condition guided by this datasheet.
4. Forward voltage measurement tolerance: $\pm 0.05\text{V}$
5. The V_F range shown in the table above indicates 99% output.
6. Tolerance of Chromaticity Coordinates x,y : ± 0.005

2. Absolute Maximum Ratings

Parameter	Symbol	Ratings	Unit
Reverse Voltage	V_R	Not designed for reverse operation	V
Power Dissipation	P_d	3750	mW
Max. DC Forward Current	I_F	50 ~ 1000	mA
Surge current	I_{FM}	2500	mA
Junction Temperature	T_J	150	°C
Operating Temperature	T_{opr}	-40 ~ +125	°C
Storage Temperature	T_{stg}	-40 ~ +125	°C
ESD Sensitivity	ESD_{HBM}	8	kV
Soldering Temperature	Reflow	260°C for 30 sec	°C

3. Characteristics Graph

Wavelength Characteristics Relative Spectral Distribution
@ Ts = 25°C, I_F=700mA

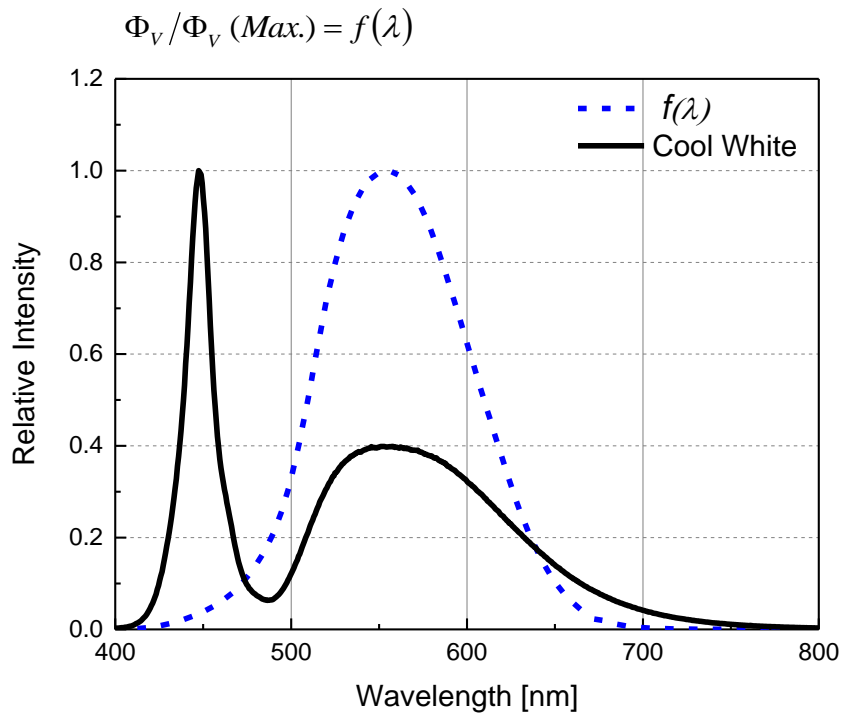

Typical Diagram Characteristics of Radiation

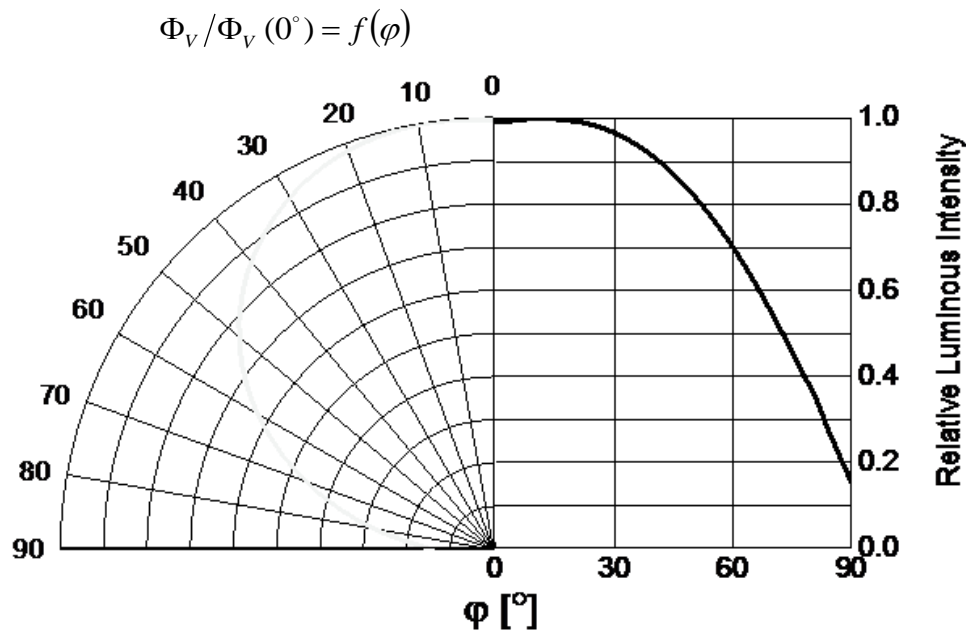

Notes:

1. φ is the off axis angle from lamp centerline where the luminous intensity is 1/2 of the peak value.
2. View angle tolerance is $\pm 5^\circ$.

Forward Current vs. Forward Voltage @ Ts = 25°C

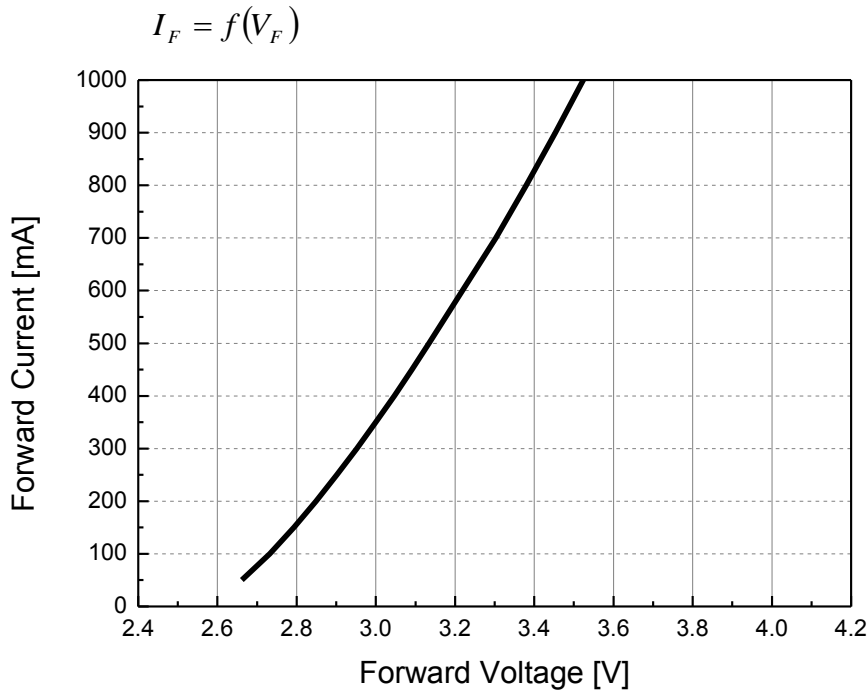

Relative Luminous Flux vs. Forward Current @ Ts = 25°C

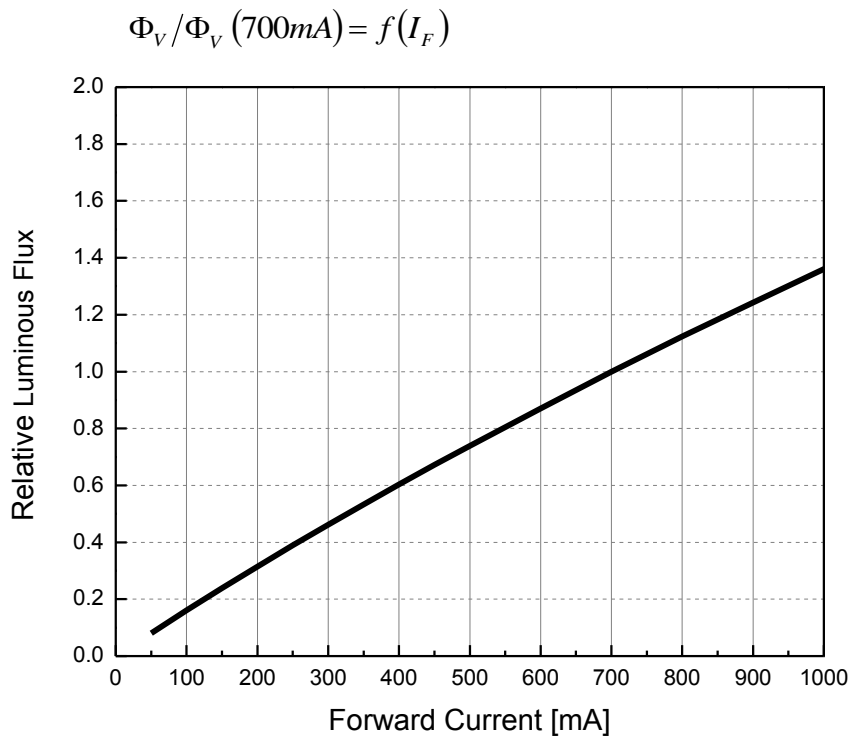

Chromaticity Coordinates vs. Forward Current
@ $T_s = 25^\circ\text{C}$

$$\Delta CIE_x, \Delta CIE_y = f(I_F)$$

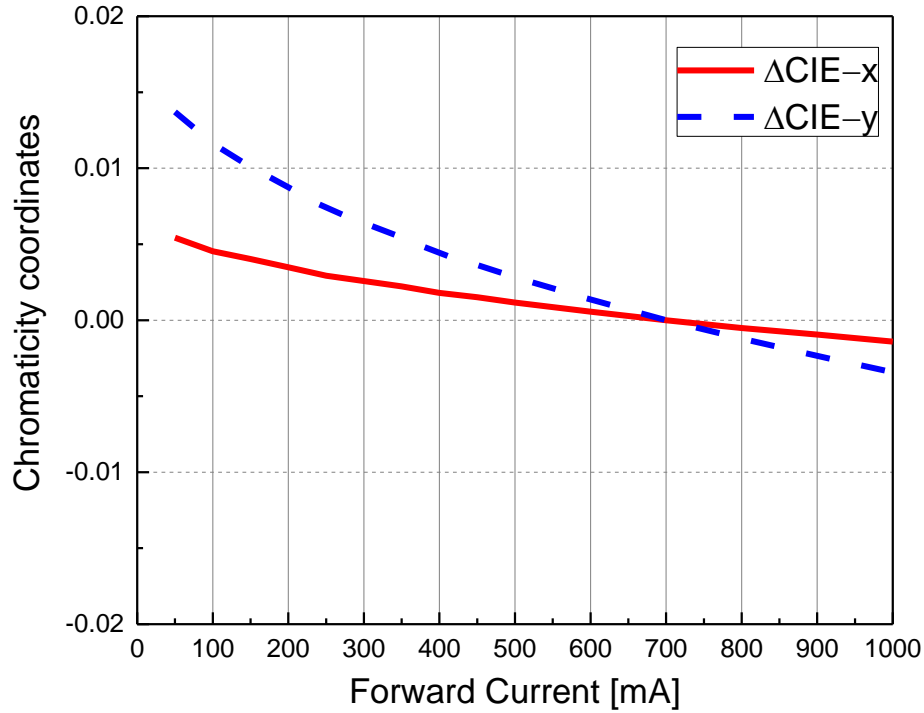

Relative Forward Voltage vs. Junction Temperature
@ $I_F=700\text{mA}$

$$\Delta V_F = V_F - V_F(25^\circ\text{C}) = f(T_j)$$

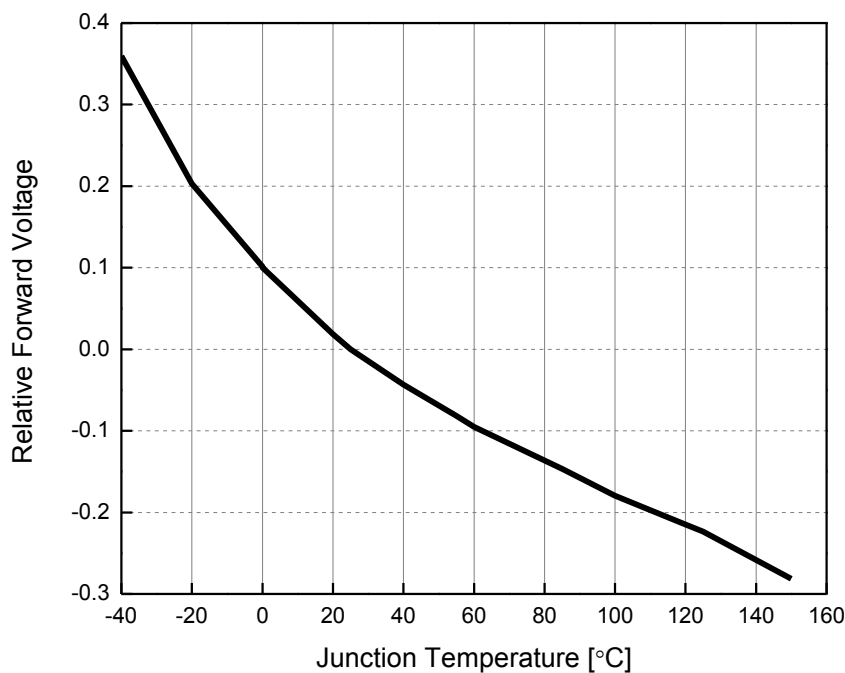

Relative Luminous Flux vs. Junction Temperature

@ I_F=700mA

$$\Phi_v / \Phi_v(25^\circ C) = f(T_j)$$

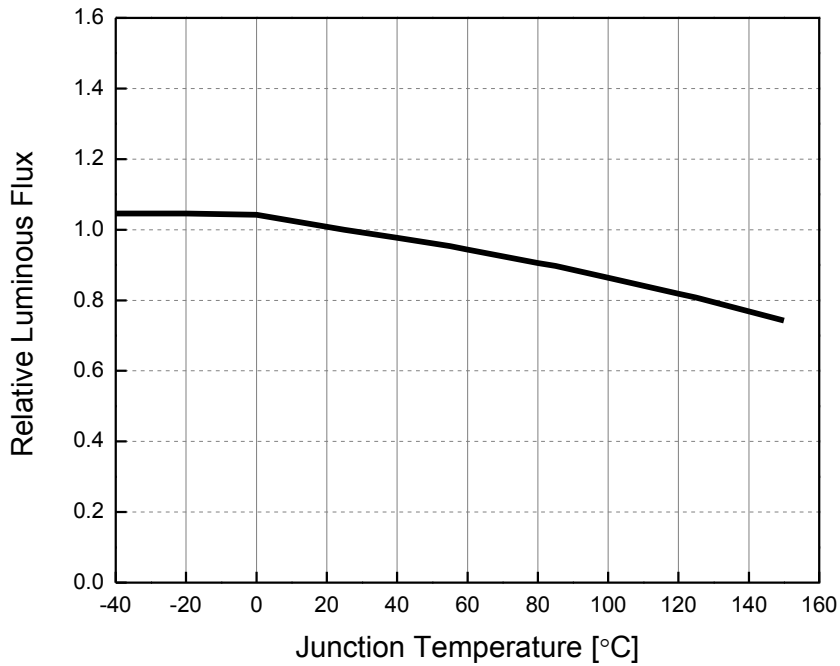

Chromaticity Coordinates Shift CIE X/Y vs. Junction Temperature

@ I_F=700mA

$$\Delta CIE x, \Delta CIE y = f(T_j)$$

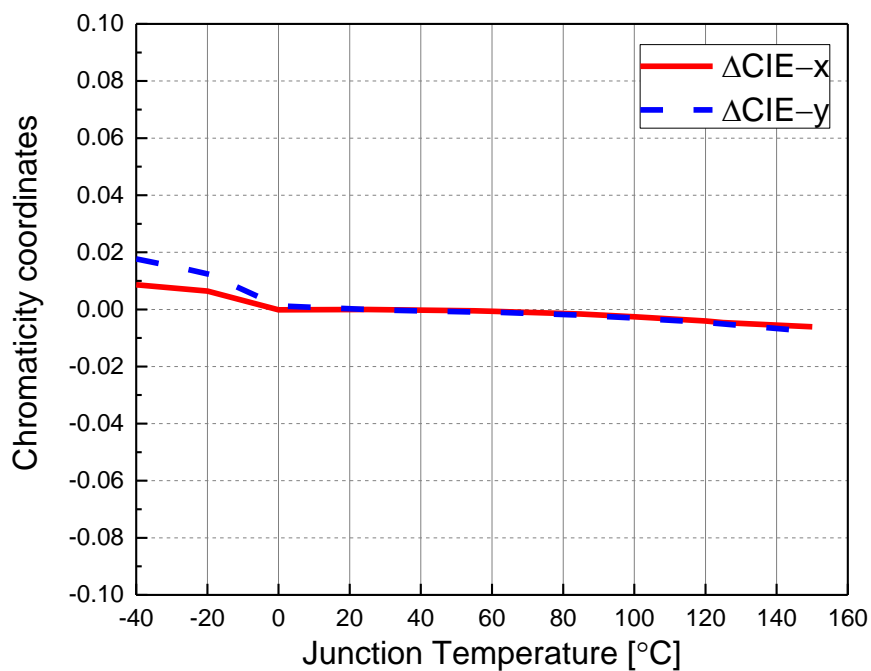

Forward Current Derating Curve

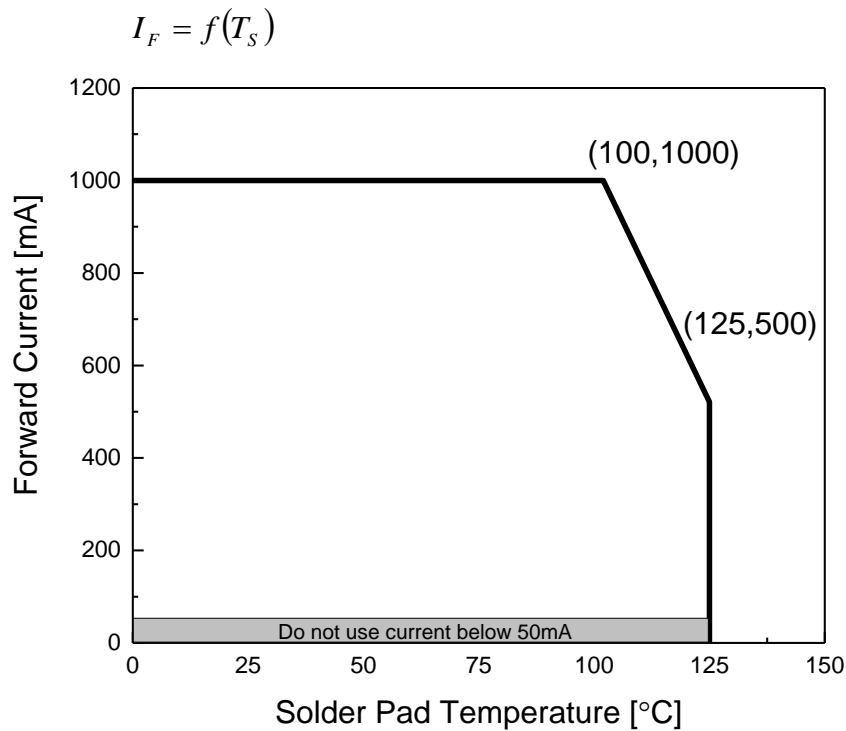

Permissible Pulse Handling Capability

D=Duty cycle , $T_s = 25C$

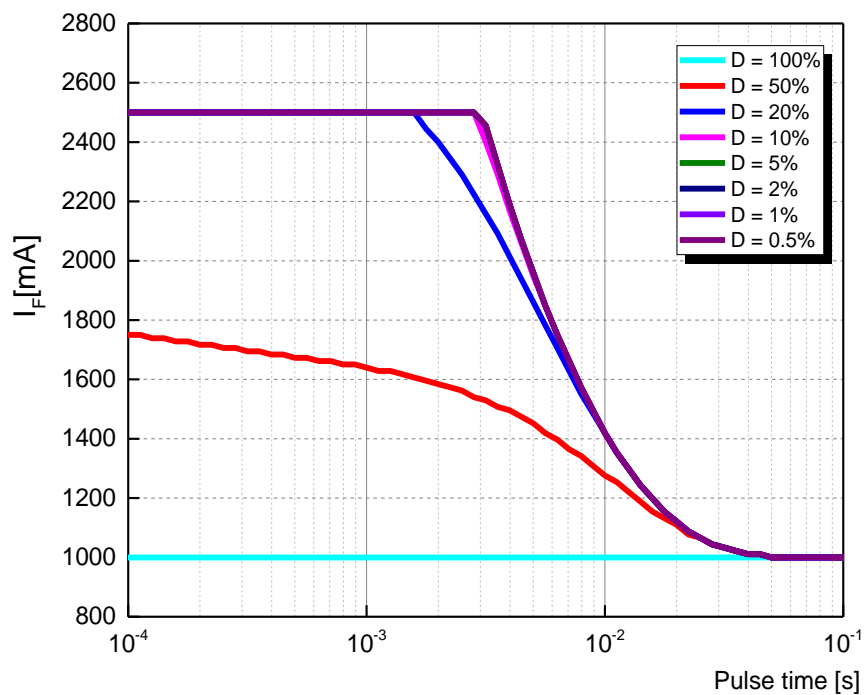

4. Binning Information

Luminous Intensity Bins

Group	Bin	Minimum Photometric Flux (lm)	Maximum Photometric Flux (lm)
E	1	4	5
	2	5	6
	3	6	8
	4	8	10
	5	10	13
	6	13	17
	7	17	20
	8	20	23
	9	23	27
F	1	27	33
	2	33	39
	3	39	45
	4	45	52
	5	52	60
	6	60	70
	7	70	80
	8	80	90
	9	90	100

Group	Bin	Minimum Photometric Flux (lm)	Maximum Photometric Flux (lm)
J	1	100	110
	2	110	120
	3	120	130
	4	130	140
	5	140	150
	6	150	160
	7	160	180
	8	180	200
	9	200	225
K	1	225	250
	2	250	275
	3	275	300
	4	300	325
	5	325	350
	6	350	375
	7	375	400
	8	400	425
	9	425	450

Notes:

1. Luminous flux measurement tolerance: $\pm 8\%$.
2. Highlighted Black Box is available bins.

Color Bin Structure ECE White Bin Structure

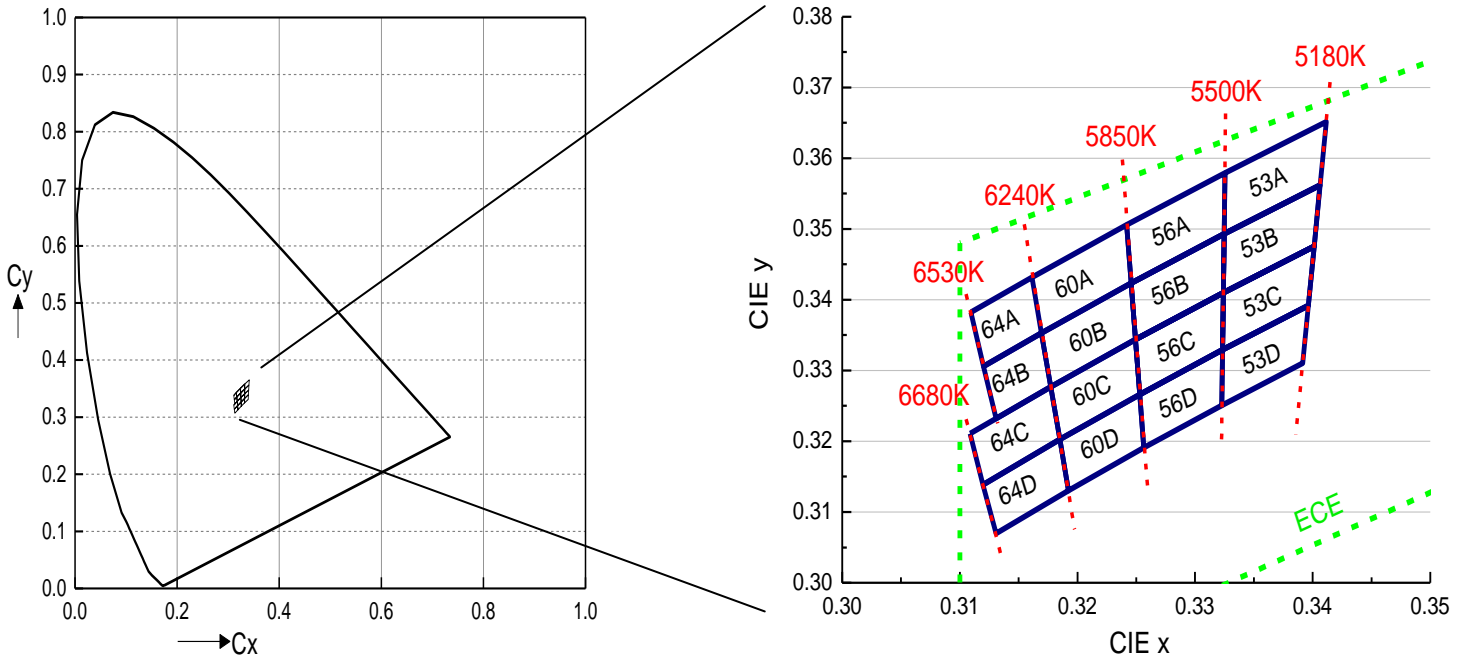

Cool White Bin Coordinates

Bin	CIE x	CIE y
64A	0.3109	0.3382
	0.3161	0.3432
	0.3169	0.3353
	0.3120	0.3306
Reference Range: 6240~6530K		

Bin	CIE x	CIE y
64B	0.3120	0.3306
	0.3169	0.3353
	0.3177	0.3277
	0.3131	0.3232
Reference Range: 6240~6530K		

Bin	CIE x	CIE y
64C	0.3109	0.3211
	0.3177	0.3277
	0.3185	0.3203
	0.3120	0.3139
Reference Range: 6240~6680K		

Bin	CIE x	CIE y
64D	0.3120	0.3139
	0.3185	0.3203
	0.3192	0.3131
	0.3131	0.3070
Reference Range: 6240~6680K		

Cool White Bin Coordinates

Bin	CIE x	CIE y
60A	0.3161	0.3432
	0.3242	0.3506
	0.3246	0.3424
	0.3169	0.3353
Reference Range: 5850~6240K		

Bin	CIE x	CIE y
60B	0.3169	0.3353
	0.3246	0.3424
	0.3249	0.3344
	0.3177	0.3277
Reference Range: 5850~6240K		

Bin	CIE x	CIE y
60C	0.3177	0.3277
	0.3249	0.3344
	0.3253	0.3266
	0.3185	0.3203
Reference Range: 5850~6240K		

Bin	CIE x	CIE y
60D	0.3185	0.3203
	0.3253	0.3266
	0.3256	0.3191
	0.3192	0.3131
Reference Range: 5850~6240K		

Bin	CIE x	CIE y
56A	0.3242	0.3506
	0.3325	0.3579
	0.3325	0.3493
	0.3246	0.3424
Reference Range: 5500~5850K		

Bin	CIE x	CIE y
56B	0.3246	0.3424
	0.3325	0.3493
	0.3324	0.3410
	0.3249	0.3344
Reference Range: 5500~5850K		

Bin	CIE x	CIE y
56C	0.3249	0.3344
	0.3324	0.3410
	0.3323	0.3329
	0.3253	0.3266
Reference Range: 5500~5850K		

Bin	CIE x	CIE y
56D	0.3253	0.3266
	0.3323	0.3329
	0.3323	0.3251
	0.3256	0.3191
Reference Range: 5500~5850K		

Bin	CIE x	CIE y
53A	0.3325	0.3579
	0.3412	0.3652
	0.3406	0.3562
	0.3325	0.3493
Reference Range: 5180~5500K		

Bin	CIE x	CIE y
53B	0.3325	0.3493
	0.3406	0.3562
	0.3401	0.3476
	0.3324	0.3410
Reference Range: 5180~5500K		

Bin	CIE x	CIE y
53C	0.3324	0.3410
	0.3401	0.3476
	0.3396	0.3392
	0.3323	0.3329
Reference Range: 5180~5500K		

Bin	CIE x	CIE y
53D	0.3323	0.3329
	0.3396	0.3392
	0.3392	0.3310
	0.3323	0.3251
Reference Range: 5180~5500K		

Notes:

1. Tolerance of Chromaticity Coordinates x,y : ±0.005

Forward Voltage Bins

Bin code	Forward Voltage [V]
10	1.00
12	1.25
15	1.50
17	1.75
20	2.00
22	2.25
25	2.50
27	2.75
30	3.00
32	3.25
35	3.50
37	3.75
40	4.00
42	4.25
45	4.50
47	4.75
50	5.00
52	5.25
55	5.50
57	5.75
60	6.00
62	6.25
65	6.50
67	6.75
70	7.00

Notes:

1. Bin code defines either Minimum or Maximum Value of the Bin.
2. Forward voltage measurement tolerance: $\pm 0.05V$.
3. Forward voltage bins are defined at $I_F = 700mA$ operation.
4. Highlighted Black Box is available bins.

5. Part Number

CH2319-C07001H-AM

Part number is designated with below details.

CH2319 = Product family name.

C = Color ^[1]

0 = CRI (0=N/A ; >70%=7 ; >80%=8 ; >90%=9)

700 = Test current [mA]

1 = Metallic Plating Type (0=Ag ; 1=Au)

H = Brightness Level (H=High ; L=Low)

AM = Automotive Application

Note

^[1] Color :

Symbol	Description
C	Cool White
N	Neutral White
W	Warm White
PA	Phosphor Converted Amber
PR	Phosphor Converted Red
UB	Blue
IB	Ice Blue
SB	Sky Blue
UG	Green
UY	Yellow
UA	Amber
UR	Red
SR	Super Red
RGB	RGB – Color
RGBY	RGBY – Color

6. Ordering Information

CH2319-C07001H- **ABCDEFGHIJKLMNO-PQ**-AM

Part Number of the EL 2319	Order Code
CH2319-C07001H-AM	CH2319-C07001H-53A64DK1K42737-2T-AM

Order code contains information with below details :

ABCDEF = min/max wavelength or CCT

GHJK = min./max. luminous flux in [lm] or luminous intensity in [mcd]

LMNO = min./max. forward voltage

PQ =Internal code

AM = Automotive Application

7. Mechanical Dimension

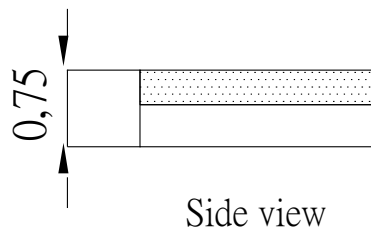
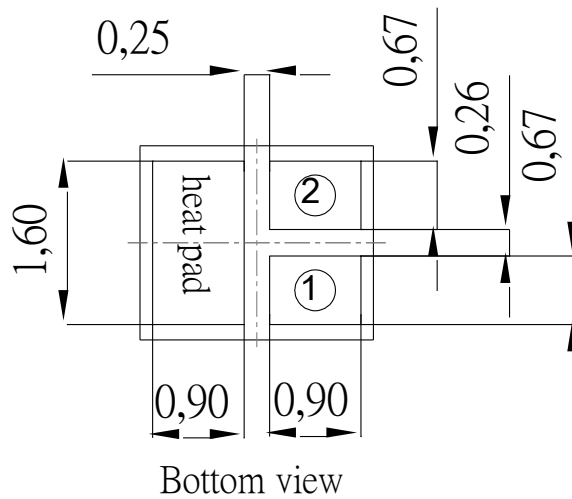
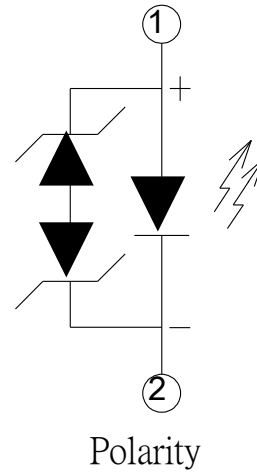
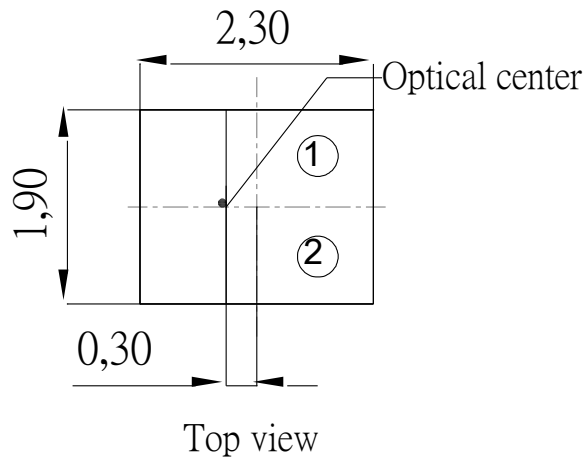

Notes:

1. Dimensions are in millimeters.
2. Tolerances unless mentioned are ± 0.1 mm.

8. Recommended Soldering Pad

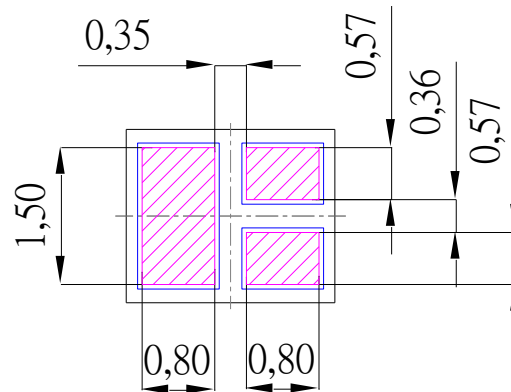

9. Reflow Soldering Profile

Soldering Condition (Reference: IPC/JEDEC J-STD-020D)

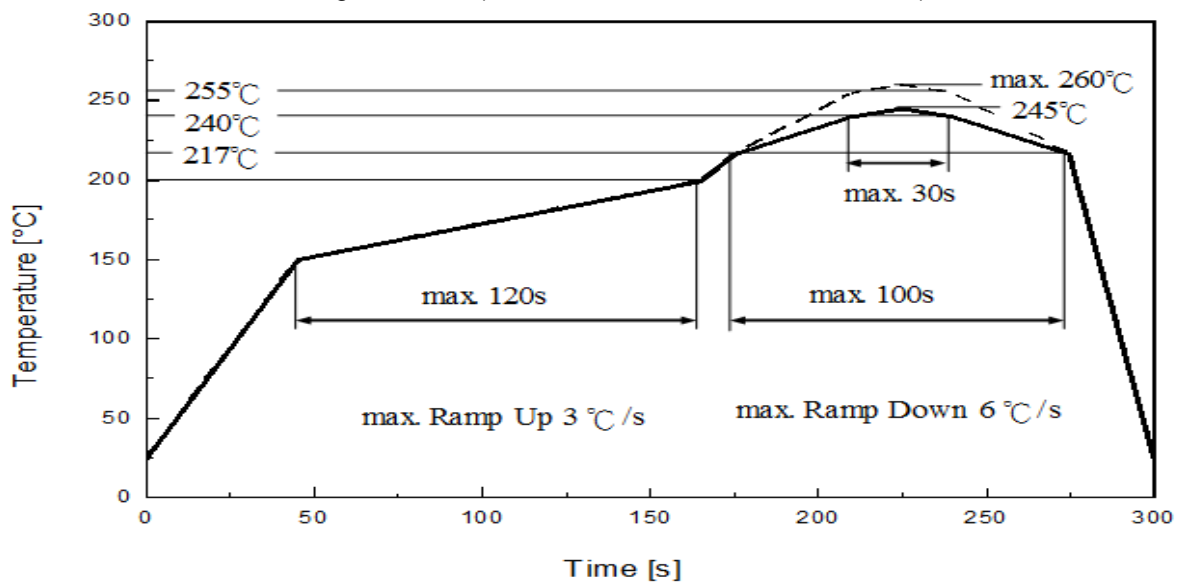

Profile Feature	Pb-Free Assembly	Unit Einheit
	Recommendation	
Ramp-up rate to preheat 25 °C to 150 °C	3	°C /sec
Time of soaking zone 150 °C to 200 °C	120	sec
Ramp-up rate to peak	3	°C /sec
Liquidus temperature	217	°C
Time above liquidus temperature	100	sec
Peak temperature (max.)	260	°C
Time within 5°C of the specified peak temperature	30	sec
Ramp-down Rate (max.)	6	°C /sec

10. Packaging Information

• Product Labeling

RoHS (Pb) EVERLIGHT 5

CPN: XXXXXXXXXXXXXXXXXXXX
 XXXXXXXXXXX-XXXXXXXX-XXXXXXXX-XXXXXXXX-XXXXXX
 P/N: XXXXXXXXXXX
 XXXXXXXXXXX-XXXXXXXX-XXXXXXXX-XXXXXXXX-XXXXXX
 LOT NO: Y150716XXX-XXXXXXXX-XXXXXXXX
 QTY: 0123456789 HUE: XXXXXXXXXXX
 CAT: XXXXXXXXXXX REF: XXXXXXXXXXX
 REFERENCE: BTPYMMDDXXXX
 MSL-X MADE IN XXXXXX



- CPN : Customer's Product Number
- P/N : Everlight Part Number
- QTY : Packing Quantity
- CAT : Luminous Flux (Brightness) Bin
- HUE : Color Bin
- REF : Forward Voltage Bin
- LOT No : Lot Number

• Packing: Loaded Quantity 2000 pcs Per Reel

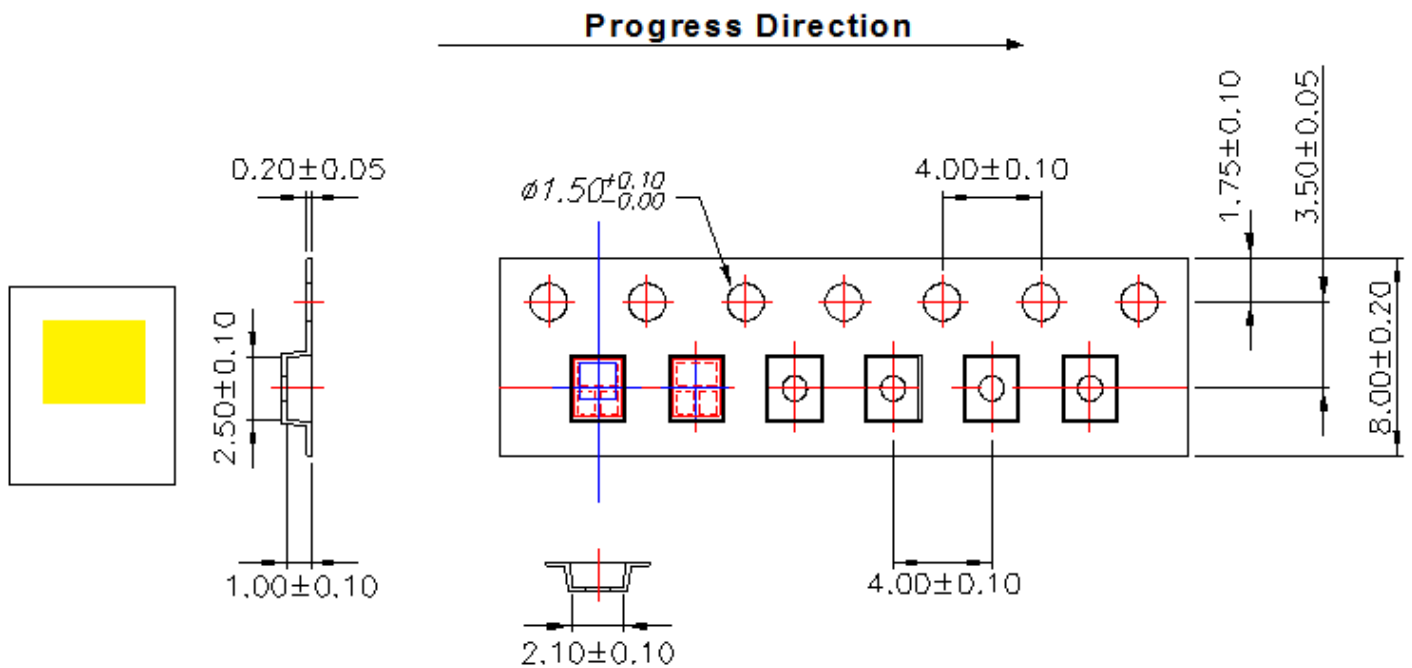

Notes:

1. Dimensions are in millimeters.
2. Tolerances for fixed dimensions are ±0.2mm.

● Reel Dimensions

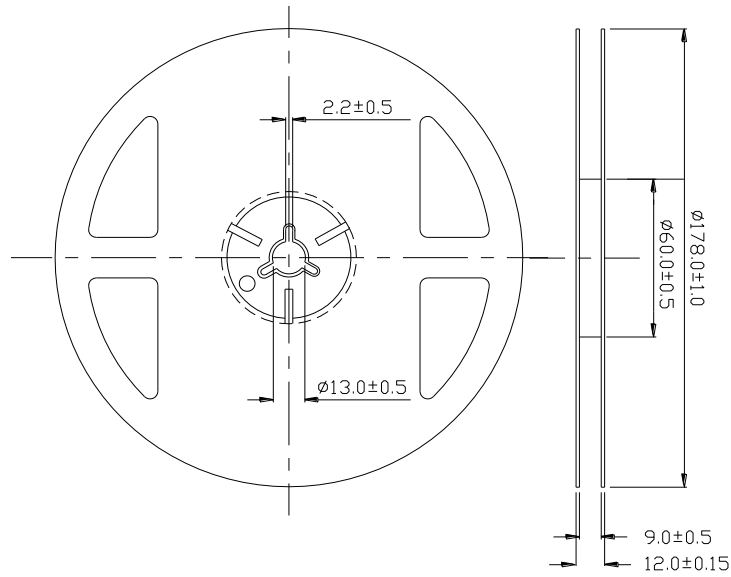

Notes:

1. Dimensions are in millimeters.
2. Tolerances unless mentioned are ± 0.2 mm.

● Moisture Resistant Packing Process

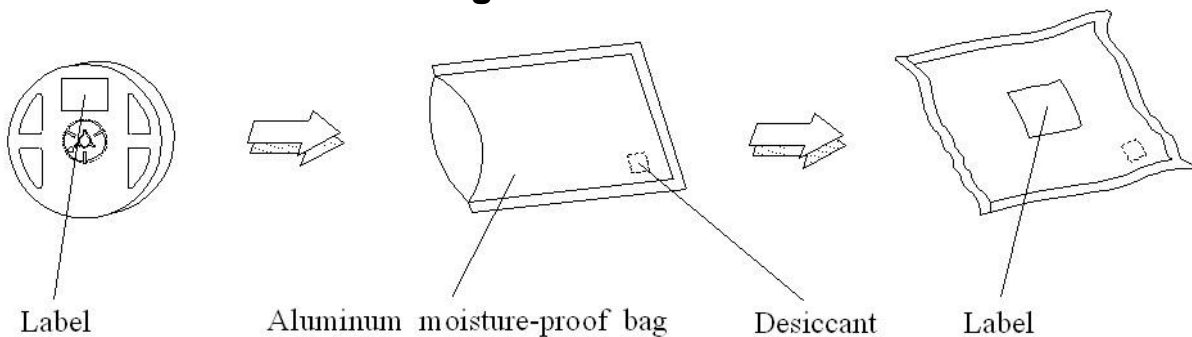

Notes:

1. Dimensions are in millimeters.
2. Tolerances unless mentioned are ± 0.2 mm.

11. Handling of Silicon Resin for LEDs

- Do not put mechanical stress on the LED.
- When handling the product, do not apply direct pressure on the optical surface. The LED surface could be damaged, which could affect the optical performance of the LED.
- In low-humidity work environment, please keep handling the LEDs with appropriate ESD grounding.
- It is recommended to handle the LED with powder-less latex gloves.
- Do not touch the resin with tweezers to avoid scratching or other damage.

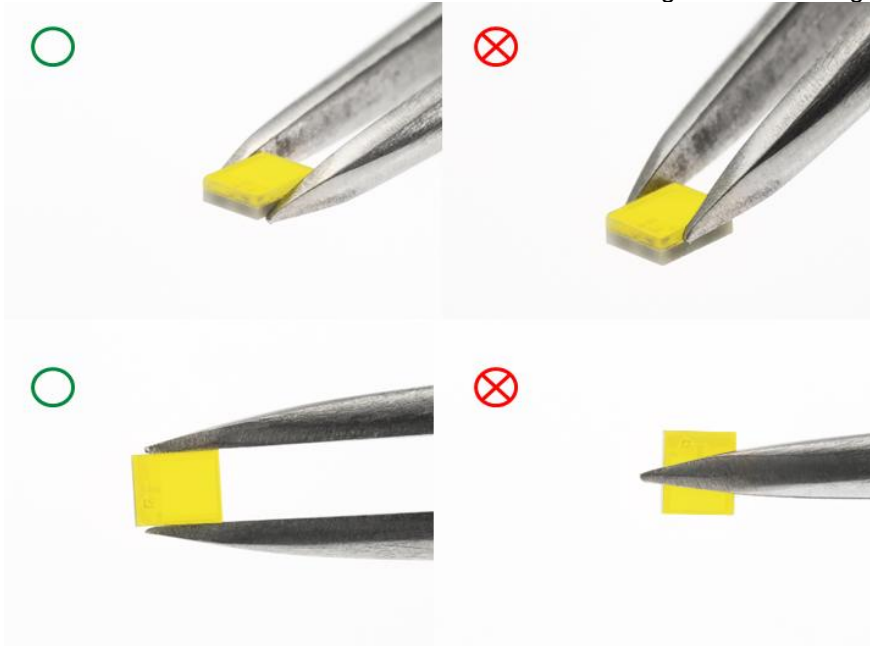

12. Precaution for Use

- Before the package is opened, the LEDs should be stored at 30°C or less and 90%RH or less after being shipped from Everlight and the storage life limits are 18 months. The LEDs can be stored up to 3 years in a sealed container with a nitrogen atmosphere and moisture absorbent material.
- After opening the package, all unused LEDs are recommended to be stored in moisture proof packages.
- If the moisture absorbent material (silica gel) has exceeded effectiveness or the LEDs have exceeded the storage time, baking treatment should be performed using the following conditions. Baking treatment: 60±5°C for 24 hours.

Revision History

Current version: Dec.28.2016
Issue No: Preliminary
Version: 0.1
Created by: Sherry Chen

Rev.	Subjects (major change in previous version)	Modified date
0.1	Preliminary	2016/12/28

单击下面可查看定价，库存，交付和生命周期等信息

[>>Everlight \(亿光\)](#)