

Halogen free

NOTE:

- MATERIAL
 - HOUSING/ACTUATOR:THERMOPLASTIC RESIN,UL94V-0,BLACK
 - TERMINAL:COPPER ALLOY,T=0.15
 - LOCK TERMINAL:COPPER ALLOY,T=0.12
 - GROUND TERMINAL:COPPER ALLOY,T=0.12
- FINISH
 - TERMINAL:Au FLASH ON ALL OVER Ni UNDER PLATING.
 - LOCK TERMINAL:MATTE TIN IN ALL OVER Ni UNDER PLATING.
 - GROUND TERMINAL:MATTE TIN ON ALL OVER Ni UNDER PATING.
- CO-PLANARITY:0.10 MAX.
- THICKNESS OF A METAL MASK:0.1MM
- FFC/FPC WITH SHIELDED
 - DIFFERENTIAL IMPEDANCE:100±10Ω @0.33t

- OTHER

THIS PRODUCT MEETS EUROPEAN UNION DIRECTIVES AND OTHER COUNTRY REGULATIONS AS DESCRIBED IN GS-47-0004
- PART NO.:

F308-1B7*1-210**-E200 (The high-speed version,With convex hull)

REV.	ECR/ECN No.	DESCRIPTION	DRAWN/DATE	CHECKED/DATE	APPROVED/DATE
A	/	New release	May 2019-06-10	Rain 2019-06-10	Leo 2019-06-10
B	/	Add plating Part No.	Shuhong Chen 2020-03-03	Rain 2020-03-03	Leo 2020-03-03
C	/	Update the format	Shuhong Chen 2020-06-22	Rain 2020-06-22	Leo 2020-06-22

DIMENSION LIST:

NO. OF POSITIONS	A	B	C	D	E	F	G
06	10.2	5.5	2.5	2.5	8.1	5.44	3.3
08	11.2	6.5	2.5	3.5	9.1	6.44	4.3
09	11.7	7.0	2.5	4.0	9.6	6.94	4.8
10	12.2	7.5	2.5	4.5	10.1	7.44	5.3
14	14.2	9.5	2.5	6.5	12.1	9.44	7.3
16	15.2	10.5	7.5	7.5	13.1	10.44	8.3
20	17.2	12.5	7.5	9.5	15.1	12.44	10.3
22	18.2	13.5	7.5	10.5	16.1	13.44	11.3
24	19.2	14.5	7.5	11.5	17.1	14.44	12.3
26	20.2	15.5	12.5	12.5	18.1	15.44	13.3
30	22.2	17.5	12.5	14.5	20.1	17.44	15.3
32	23.2	18.5	12.5	15.5	21.1	18.44	16.3
35	24.7	20.0	12.5	17.0	22.6	19.94	17.8
40	27.2	22.5	17.5	19.5	25.1	22.44	20.3
41	27.7	23.0	17.5	20.0	25.1	22.94	20.8
50	32.2	27.5	22.5	24.5	30.1	27.44	25.3
60	37.2	32.5	27.5	29.5	35.1	32.44	30.3
65	39.7	35.0	27.5	32.0	37.6	34.94	32.8
68	41.2	36.5	32.5	33.5	39.1	36.44	34.3

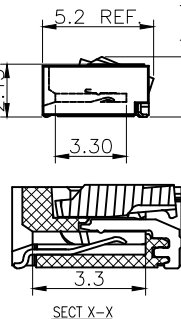
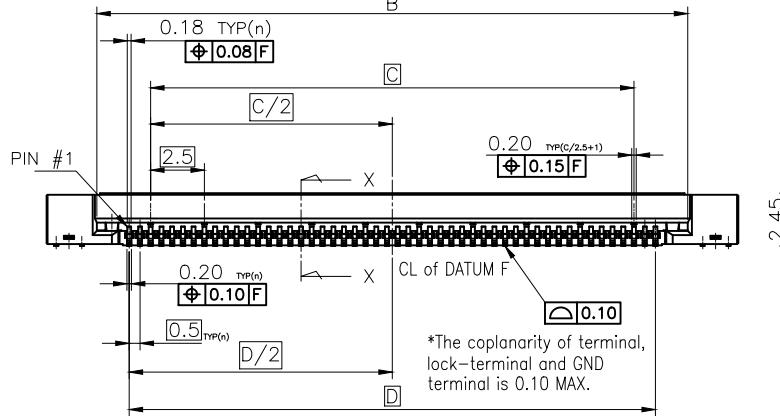
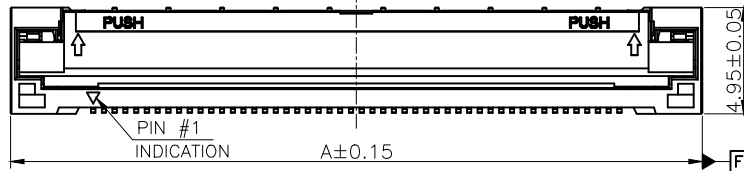

Lock release condition
2.8 REF.

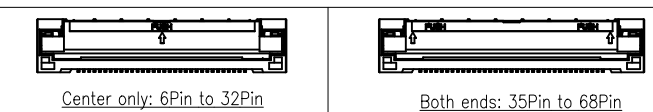
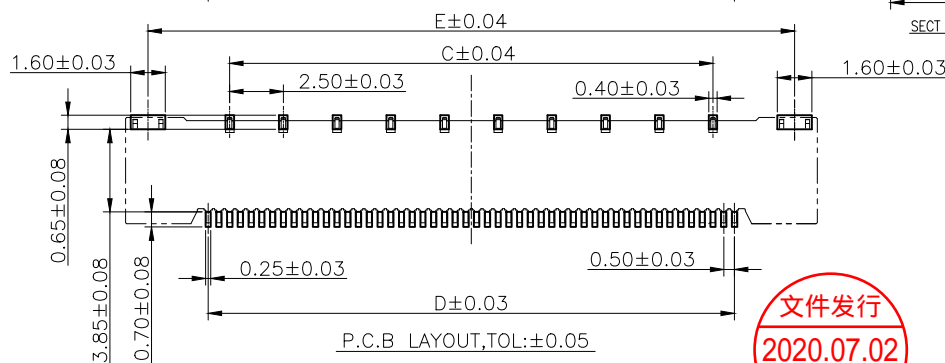
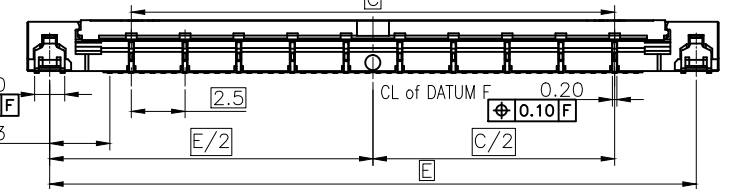

UNLESS OTHERWISE SPECIFIED TOLERANCES		ANGLE OF PROJECTION		Amphenol AORORA	
X.	±0.30	X. °	± 5'	Amphenol AORORA Technology (Huizhou) Co.,Ltd	
X.X	±0.25	X.X °	± 4'	TITLE:	
X.XX	±0.20	X.XX °	± 3'	Customer Drw	
X.XXX	±0.15	X.XXX °	± 2'	DRAWN DATE Shuhong Chen 2020-06-22	
LINEAR DIMS		ANGLES DIMS		DESIGN DATE Shuhong Chen 2020-06-22	
DWG NO.:	A-S0551	CHECKED DATE	Rain 2020-06-22	SIZE	PART NUMBER:
MATERIAL	SEE NOTES	APPROVED DATE	Leo 2020-06-22	A4	F308-1B7*1-210**-E200
FINISHED	SEE NOTES			SCALE	3:1
				UNIT	mm
				SHEET	1 OF 3

文件发行
2020.07.02
Aorora

This document is the property of and embodies CONFIDENTIAL and PROPRIETARY information of AORORA. No part of the information shown on this document may be used in any way or disclosed to others without the written consent of AORORA. © 2019 AORORA

This document is the property of and embodies CONFIDENTIAL and PROPRIETARY information of AOR. No part of the information shown on this document may be used in any way or disclosed to others without the written consent of AOR. © 2019 AOR



FFC PATTERN DIMENSION

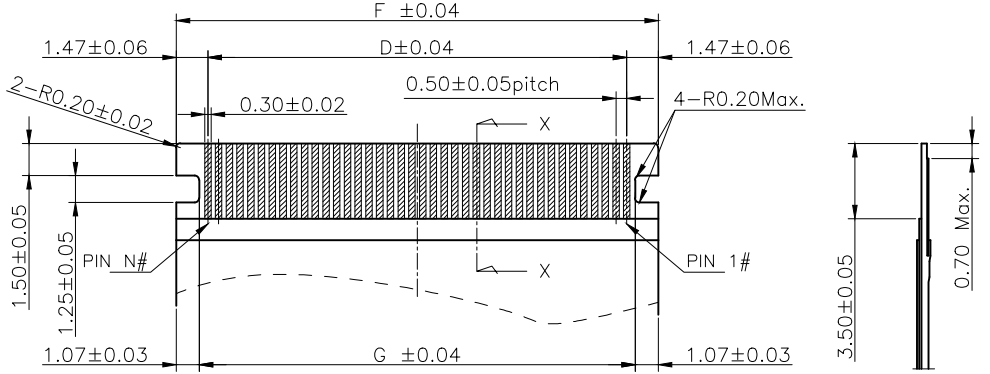

NO	COMPONENT NAME	MATERIAL	FINISH
1	CONDUCTOR	COPPER ALLOY	0.05um Min. Au plating, over 0.5Ni um plating
2	INSULATION FILM	OPTIONAL	
3	STIFFENER BOARD	OPTIONAL	Prohibition of multilayer construction of thin material
4	GROUND PLATE	MATAL FILM	Sn plating
5	Intermediate layer	OPTIONAL	
6	GROUND PLATE	MATAL FILM	

RECOMMENDED FFC TYPE-1 DIMENSION (WITH SHIELDED)

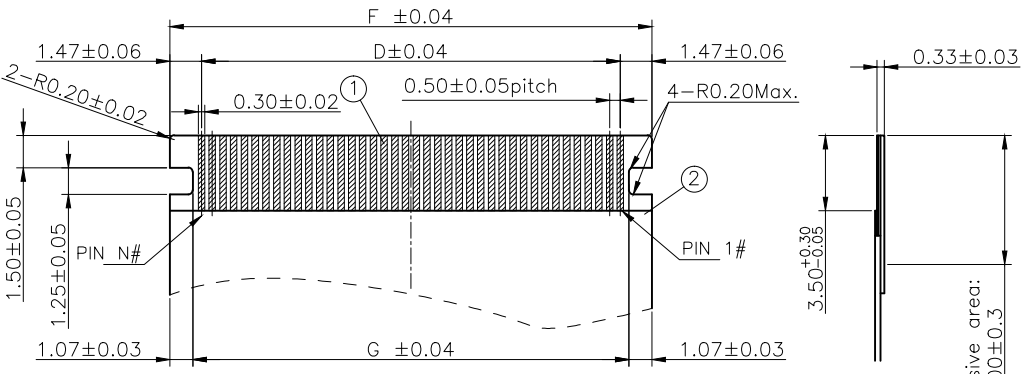

RECOMMENDED FFC TYPE-2 DIMENSION

NO	COMPONENT NAME	MATERIAL	FINISH
1	CONDUCTOR	COPPER ALLOY	0.05um Min. Au plating, over 0.5Ni um
2	INSULATION FILM	OPTIONAL	
3	STIFFENER BOARD	OPTIONAL	Prohibition of multilayer construction of thin material

REV.	ECR/ECN No.	DESCRIPTION	DRAWN/DATE	CHECKED/DATE	APPROVED/DATE
A	/	New release	May 2019-06-10	Rain 2019-06-10	Leo 2019-06-10
B	/	Add plating Part No.	Shuhong Chen 2020-03-03	Rain 2020-03-03	Leo 2020-03-03
C	/	Update the format	Shuhong Chen 2020-06-22	Rain 2020-06-22	Leo 2020-06-22

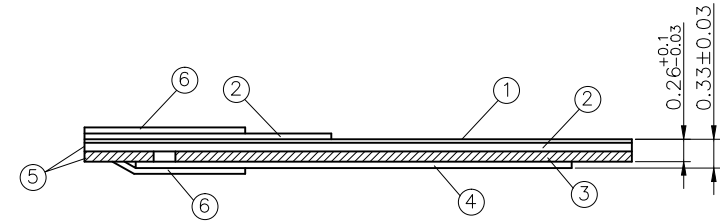
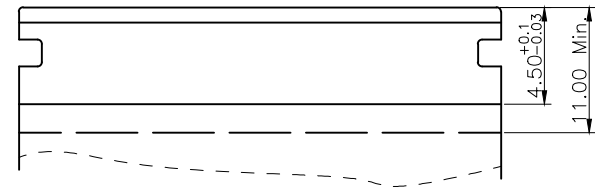

REFERENCE FFC SECT. X-X

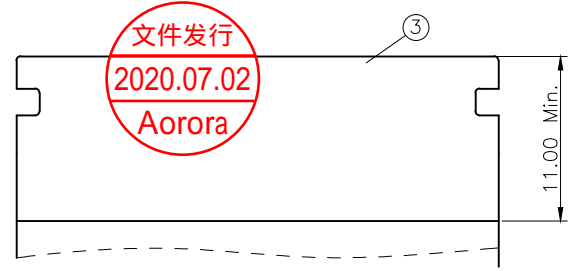

UNLESS OTHERWISE SPECIFIED TOLERANCES				ANGLE OF PROJECTION		Amphenol AORORA	
X.	±0.30	X. °	± 5'			Amphenol Aorora Technology (Huizhou) Co.,Ltd	
X.X	±0.25	X.X °	± 4'				
X.XX	±0.20	X.XX °	± 3'	Customer Drw		TITLE:	
X.XXX	±0.15	X.XXX °	± 2'	DRAWN DATE	Shuhong Chen 2020-06-22	Assembly Drawing For 0.50mm pitch Auto lock conn.	
LINEAR DIMS		ANGLES DIMS		DESIGN DATE	Shuhong Chen 2020-06-22	SIZE	PART NUMBER:
DWG NO.: A-S0551				CHECKED DATE	Rain 2020-06-22	A4	F308-1B7*1-210**-E200
MATERIAL SEE NOTES				APPROVED DATE	Leo 2020-06-22	SCALE	3:1
FINISHED SEE NOTES						UNIT	mm
						SHEET	2 OF 3

REV.	ECR/ECN No.	DESCRIPTION	DRAWN/DATE	CHECKED/DATE	APPROVED/DATE
A	/	New release	May 2019-06-10	Rain 2019-06-10	Leo 2019-06-10
B	/	Add plating Part No.	Shuhong Chen 2020-03-03	Rain 2020-03-03	Leo 2020-03-03
C	/	Update the format	Shuhong Chen 2020-06-22	Rain 2020-06-22	Leo 2020-06-22

- NOTES:
- MATERIAL:
 - CARRY TAPE:HIPS,T=0.40,CLEAR
 - REEL:HIPS,
 - SHIM:PE,CLEAR.
 - PRIMARY PACKING:1500PCS/REEL.
 - SECONDARY PACKING:SEE PACKING LIST
 - PEELING RESISTANCE: 0.4~1.4N(40~140gf); PEELING ANGLE: 165°~180°; PEELING SPEED: 300mm/minutes.

5. QTY. LIST:

DIM	NO.	6~16pin	20~26pin	30~40pin	50~68pin
P	24.00	32.00	44.00	56.00	
J	20.40	28.4	40.40	52.40	
K	11.5	14.20	20.2	26.2	
L	25.5	33.5	45.5	57.5	
N	10	8	6	5	
TOTAL(PCS)		25,000	20,000	15,000	12,500

1. PACKING INTO REEL:

PULL OUT DIRECTION

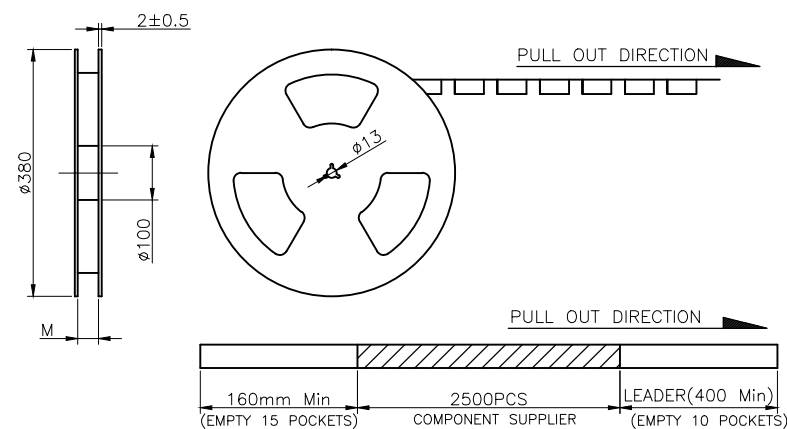
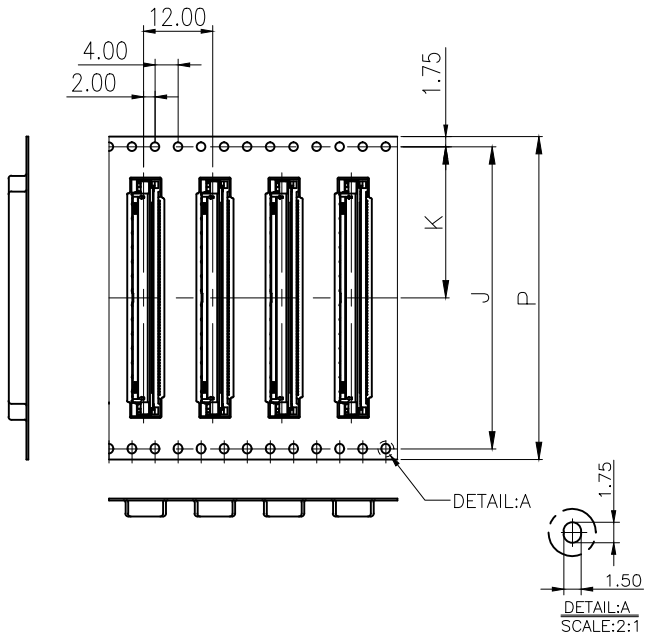

2:PACKING INTO OUTER BOX

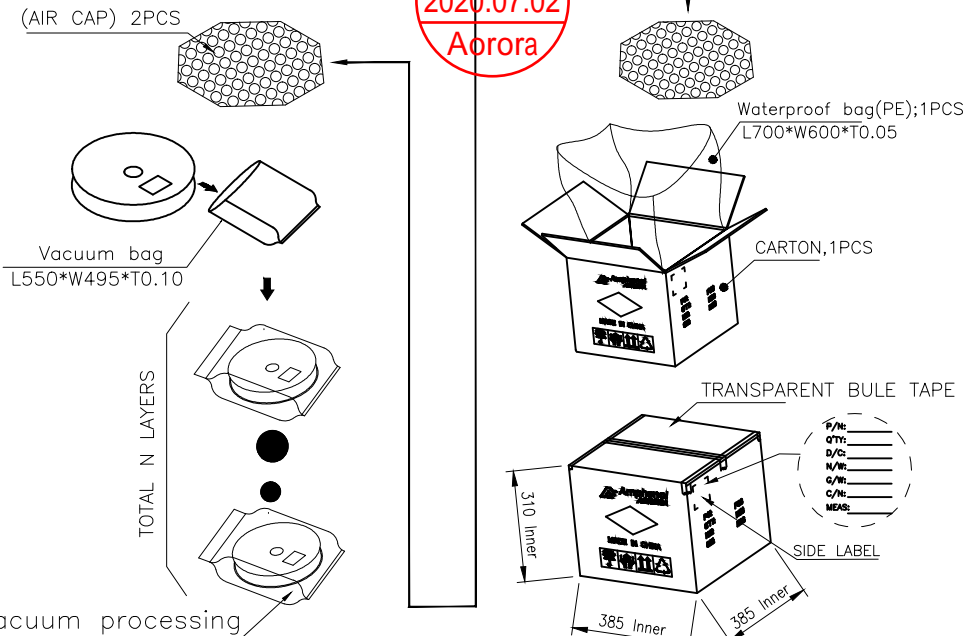

This document is the property of and embodies CONFIDENTIAL and PROPRIETARY information of AOR. No part of the information shown on this document may be used in any way or disclosed to others without the written consent of AOR. © 2019 AOR



UNLESS OTHERWISE SPECIFIED TOLERANCES				ANGLE OF PROJECTION		Amphenol AORORA	
X.	±0.30	X. °	± 5'			Amphenol AORORA Technology (Huizhou) Co.,Ltd	
X.X	±0.25	X.X °	± 4'				
X.XX	±0.20	X.XX °	± 3'	DOC TYP	Customer Drw	TITLE: Assembly Drawing For 0.50mm pitch Auto lock conn.	
X.XXX	±0.15	X.XXX °	± 2'	DRAWN DATE	Shuhong Chen 2020-06-22	SIZE	A4
LINEAR DIMS	ANGLES DIMS			DESIGN DATE	Shuhong Chen 2020-06-22	PART NUMBER:	F308-1B7*1-210**-E200
DWG NO.:	A-S0551			CHECKED DATE	Rain 2020-06-22	REV.	C
MATERIAL	SEE NOTES			APPROVED DATE	Leo 2020-06-22	SCALE	1:1
FINISHED	SEE NOTES					UNIT	mm
						SHEET	3 OF 3

单击下面可查看定价，库存，交付和生命周期等信息

[>>Amphenol\(安费诺\)](#)