

## CJ431/CD431 Adjustable Reference Source

### CJ431/CD431

Adjustable Accurate Reference Source

#### DEVICE DESCRIPTION

The CJ431/ CD431 is a three-terminal adjustable shunt regulator offering excellent temperature stability . This device has a typical dynamic output impedance of 0.2Ω. The device can be used as a replacement for zener diodes in many applications.

#### FEATURES

- The output voltage can be adjusted to 36V
- Low dynamic output impedance, its typical value is 0.2Ω
- Trapping current capability is 1 to 100mA
- Low output noise voltage
- Fast on -state response
- The effective temperature compensation in the working range of full temperature
- The typical value of the equivalent temperature factor in the whole temperature scope is 50 ppm/°C

#### APPLICATION

- Shunt Regulator
- High-Current Shunt Regulator
- Precision Current Limiter

#### Equivalent Circuit

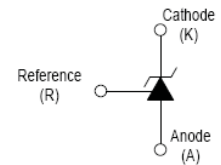

#### PIN CONNENCTIONS and MARKING

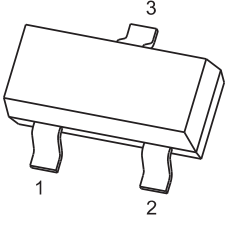
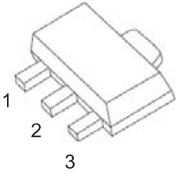
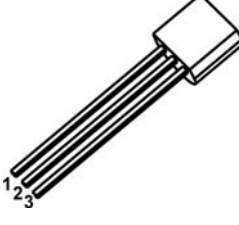
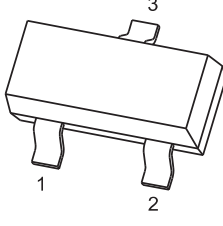
<p><b>CJ431</b></p> 	<p><b>SOT -23</b></p> <p>1.REFERENCE 2.CATHODE 3. ANODE</p>	<p><b>CJ431</b></p> 	<p><b>SOT-89</b></p> <p>1.REFERENCE 2.ANODE 3.CATHODE</p>
<p><b>CJ431</b></p> 	<p><b>TO-92</b></p> <p>1.REFERENCE 2.ANODE 3.CATHODE</p>	<p><b>CD431</b></p> 	<p><b>SOT-23</b></p> <p>1.CATHODE 2.REFERENCE 3. ANODE</p>

## ORDERING INFORMATION

Part Number	MARKING <sup>(1)</sup>	Package	Packing Method	Pack Quantity
CJ431	431	SOT-23	Reel	3000pcs/Reel
CD431	CD431	SOT-23	Reel	3000pcs/Reel
CJ431	CJ431	SOT-89	Reel	1000pcs/Reel
CJ431	CJ TL431 <sup>(2)</sup> XXX	TO-92	Bulk	1000pcs/Bag
CJ431-TA	CJ TL431 <sup>(2)</sup> XXX	TO-92	Tape	2000pcs/Box

Notes: (1). Solid dot= Green molding compound device, if none, the normal device.

(2). XXX=Code

### ABSOLUTE MAXIMUM RATINGS (Operating temperature range applies unless otherwise specified)

Parameter	Symbol	Value			Unit
		SOT-23	SOT-89	TO-92	
Cathode Voltage	$V_{KA}$	36			V
Cathode Current Range (Continuous)	$I_{KA}$	-100~+150			mA
Reference Input Current Range	$I_{ref}$	0.05~+10			mA
Power Dissipation	$P_D$	300	500	770	mW
Thermal Resistance from Junction to Ambient	$R_{\theta JA}$	417	250	162	°C/W
Operating Junction Temperature	$T_J$	-40~+125			°C
Storage Temperature Range	$T_{STG}$	-65~+150			°C

### ELECTRICAL CHARACTERISTICS ( $T_a=25^\circ\text{C}$ unless otherwise specified)

Parameter	Symbol	Test conditions	Min	Typ	Max	Unit
Reference input voltage	$V_{ref}$	$V_{KA}=V_{REF}, I_{KA}=10\text{mA}$	2.475	2.5	2.525	V
Deviation of reference Input voltage over temperature (note)	$\Delta V_{ref}/\Delta T$	$V_{KA}=V_{REF}, I_{KA}=10\text{mA}$ $T_{MIN}\leq T_a\leq T_{MAX}$		4.5	17	mV
Ratio of change in reference Input voltage to the change in cathode voltage	$\Delta V_{ref}/\Delta V_{KA}$	$I_{KA}=10\text{mA}$	$\Delta V_{KA}=10\text{V}\sim V_{REF}$	-1.0	-2.7	mV/V
			$\Delta V_{KA}=36\text{V}\sim 10\text{V}$	-0.5	-2.0	mV/V
Reference input current	$I_{ref}$	$I_{KA}=10\text{mA}, R_1=10\text{k}\Omega$ $R_2=\infty$		1.5	4	$\mu\text{A}$
Deviation of reference input current over full temperature range	$\Delta I_{ref}/\Delta T$	$I_{KA}=10\text{mA}, R_1=10\text{k}\Omega$ $R_2=\infty$ $T_A=-25\text{ to }85^\circ\text{C}$		0.4	1.2	$\mu\text{A}$
Minimum cathode current for regulation	$I_{KA(\text{min})}$	$V_{KA}=V_{REF}$		0.45	1.0	mA
Off-state cathode current	$I_{KA(\text{OFF})}$	$V_{KA}=36\text{V}, V_{REF}=0$		0.05	1.0	$\mu\text{A}$
Dynamic impedance	$Z_{KA}$	$V_{KA}=V_{REF}, I_{KA}=1\text{ to }100\text{mA}$ $f\leq 1.0\text{kHz}$		0.15	0.5	$\Omega$

Note:  $T_{MIN}=-25^\circ\text{C}$ ,  $T_{MAX}=+85^\circ\text{C}$

### CLASSIFICATION cZV<sub>ref</sub>

Rank	0.5%	1%
Range	2.487-2.513	2.475-2.525

**NOTE:** It is strongly recommended to connect a capacitor (value more than 0.1 $\mu\text{F}$ ) at the output pin to smooth the output. The capacitor should be placed as close as possible to the output pin, with the shortest path to GND.

# Typical Characteristics

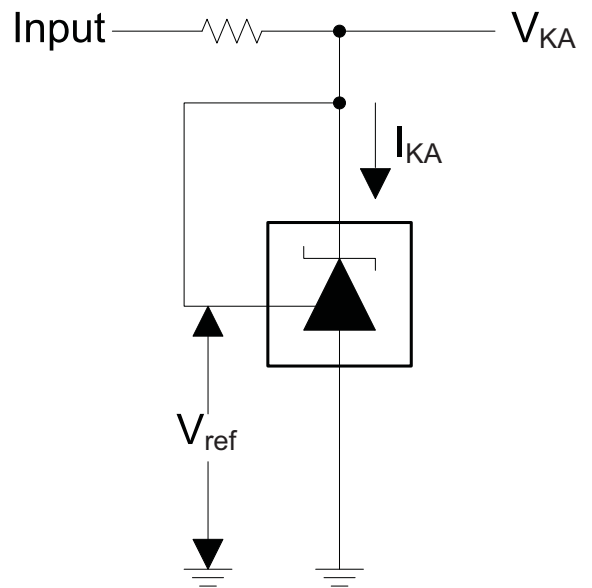
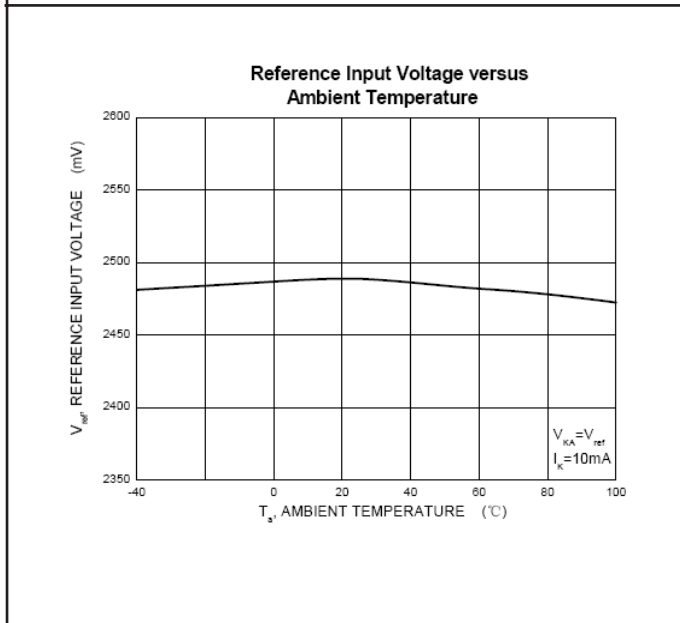
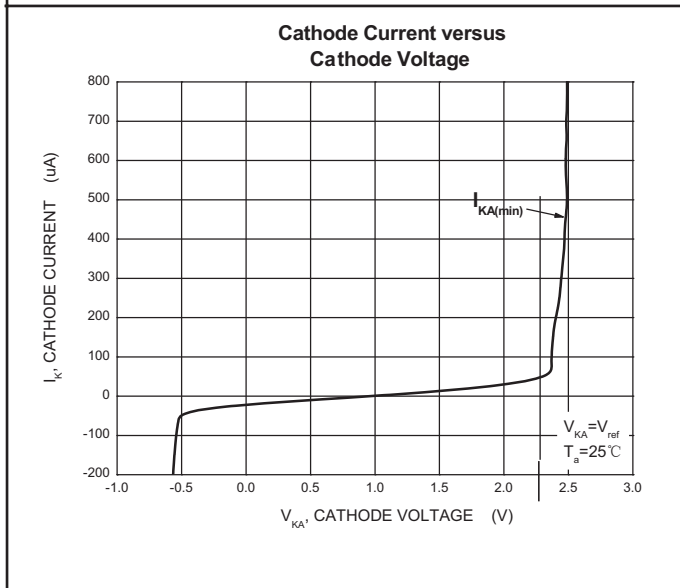
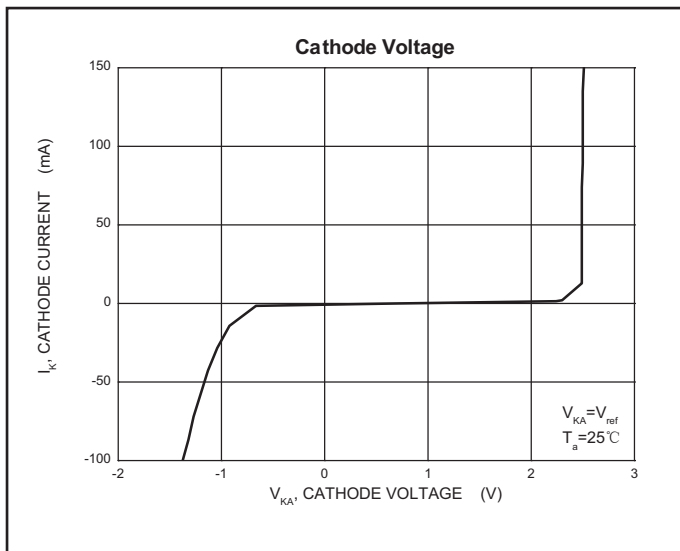

Test Circuit for  $V_{KA} = V_{ref}$

# Typical Characteristics

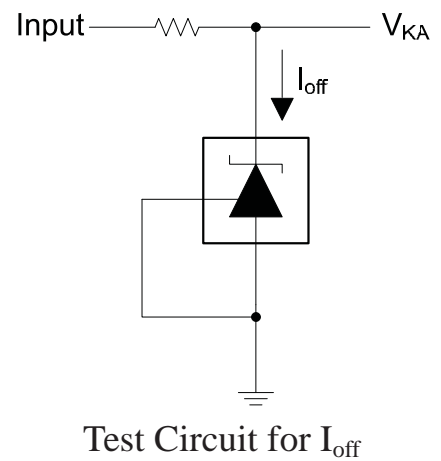
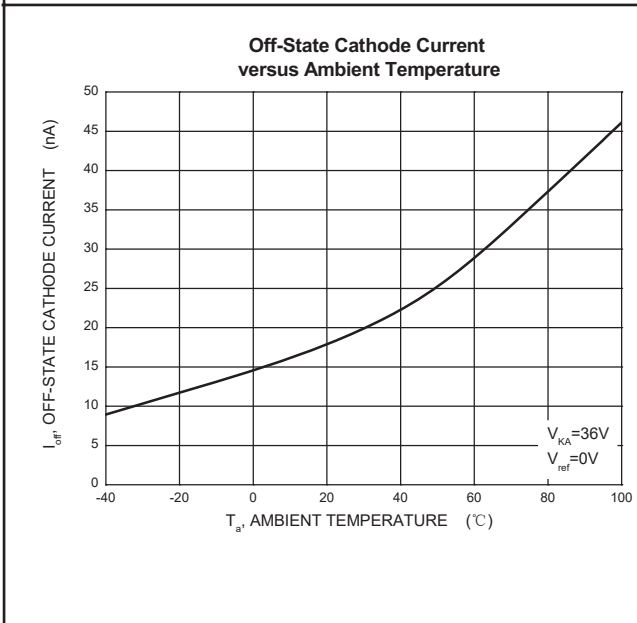
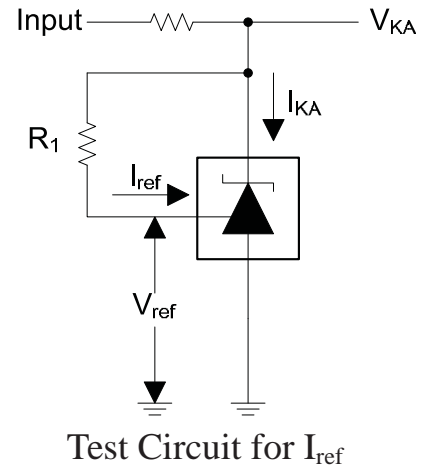
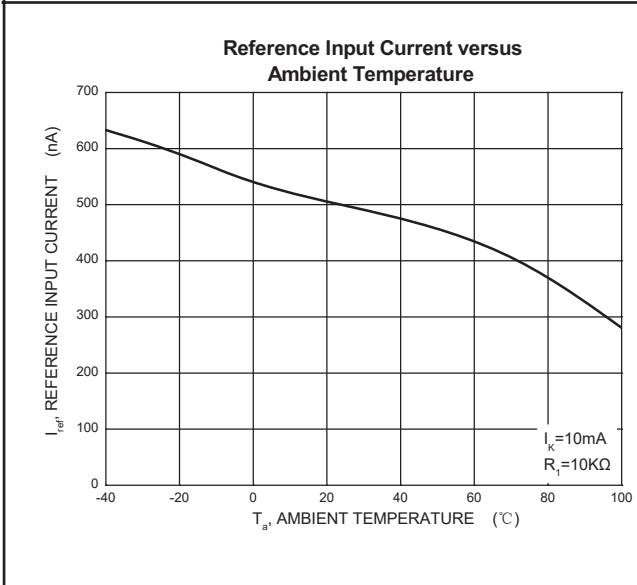
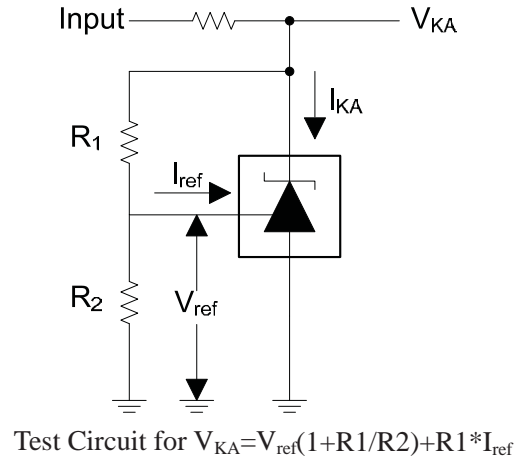
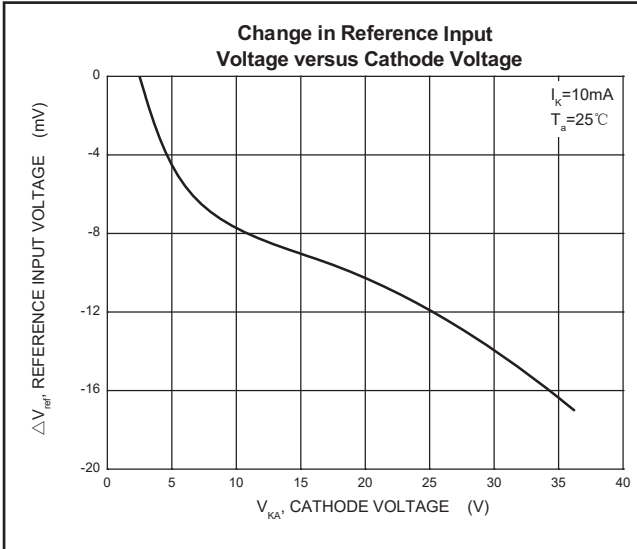

## SOT-23 Package Outline Dimensions

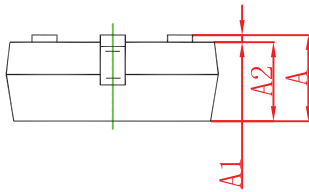
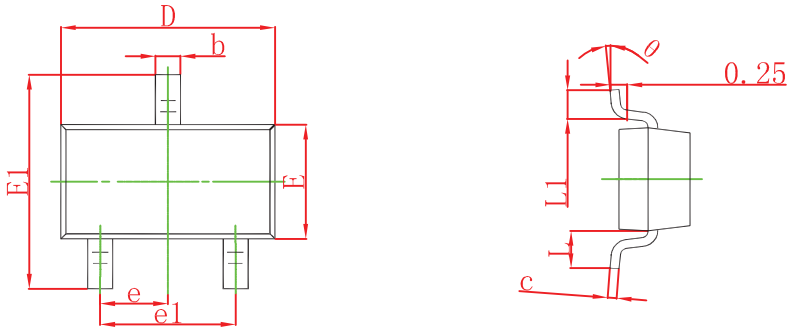

Symbol	Dimensions In Millimeters		Dimensions In Inches	
	Min	Max	Min	Max
A	0.900	1.150	0.035	0.045
A1	0.000	0.100	0.000	0.004
A2	0.900	1.050	0.035	0.041
b	0.300	0.500	0.012	0.020
c	0.080	0.150	0.003	0.006
D	2.800	3.000	0.110	0.118
E	1.200	1.400	0.047	0.055
E1	2.250	2.550	0.089	0.100
e	0.950 TYP		0.037 TYP	
e1	1.800	2.000	0.071	0.079
L	0.550 REF		0.022 REF	
L1	0.300	0.500	0.012	0.020
v	0°	8°	0°	8°

## SOT-23 Suggested Pad Layout

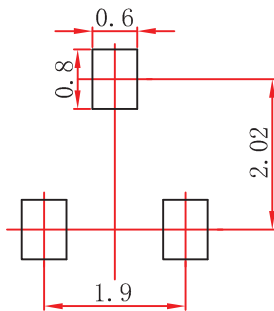

### Note:

1. Controlling dimension: in millimeters.
2. General tolerance:  $\pm 0.05\text{mm}$ .
3. The pad layout is for reference purposes only.

### NOTICE

JSCJ reserves the right to make modifications, enhancements, improvements, corrections or other changes without further notice to any product herein. JSCJ does not assume any liability arising out of the application or use of any product described herein.

# SOT-23 Tape and Reel

## SOT-23 Embossed Carrier Tape

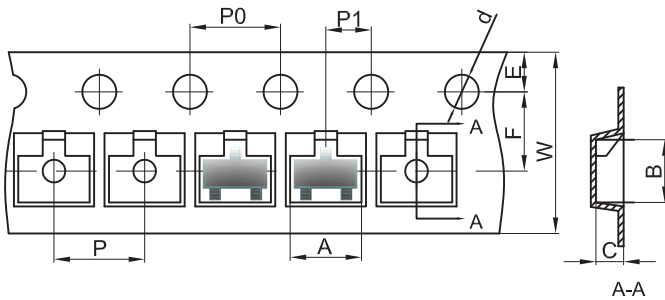

### Packaging Description:

SOT-23 parts are shipped in tape. The carrier tape is made from a dissipative (carbon filled) polycarbonate resin. The cover tape is a multilayer film (Heat Activated Adhesive in nature) primarily composed of polyester film, adhesive layer, sealant, and anti-static sprayed agent. These reeled parts in standard option are shipped with 3,000 units per 7" or 17.8cm diameter reel. The reels are clear in color and is made of polystyrene plastic (anti-static coated).

Dimensions are in millimeter

Pkg type	A	B	C	d	E	F	P0	P	P1	W
SOT-23	3.15	2.77	1.22	Ø1.50	1.75	3.50	4.00	4.00	2.00	8.00

## SOT-23 Tape Leader and Trailer

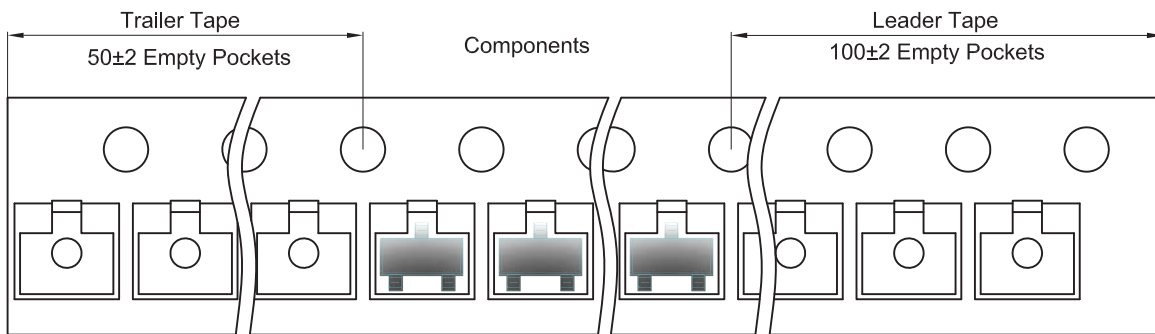

## SOT-23 Reel

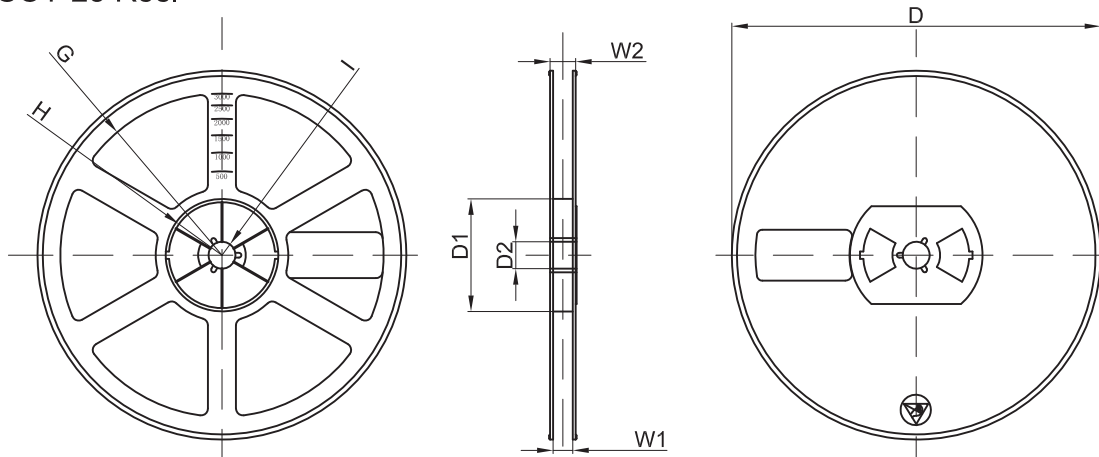

Dimensions are in millimeter

Reel Option	D	D1	D2	G	H	I	W1	W2
7" Dia	Ø178.00	54.40	13.00	R78.00	R25.60	R6.50	9.50	12.30

REEL	Reel Size	Box	Box Size(mm)	Carton	Carton Size(mm)	G.W.(kg)
3000 pcs	7 inch	45,000 pcs	203×203×195	180,000 pcs	438×438×220	

# SOT-89-3L Tape and reel

## SOT-89-3L Embossed Carrier Tape

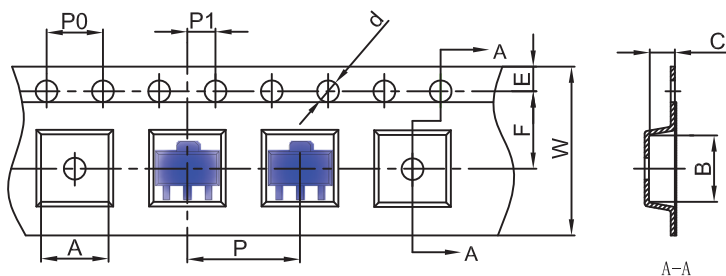

**Packaging Description:**  
 SOT-89-3L parts are shipped in tape. The carrier tape is made from a dissipative (carbon filled) polycarbonate resin. The cover tape is a multilayer film (Heat Activated Adhesive in nature) primarily composed of polyester film, adhesive layer, sealant, and anti-static sprayed agent. These reeled parts in standard option are shipped with 1,000 units per 7" or 18.0 cm diameter reel. The reels are clear in color and is made of polystyrene plastic (anti-static coated).

Dimensions are in millimeter										
Pkg type	A	B	C	d	E	F	P0	P	P1	W
SOT-89-3L	4.85	4.45	1.85	Ø1.50	1.75	5.50	4.00	8.00	2.00	12.00

## SOT-89-3L Tape Leader and Trailer

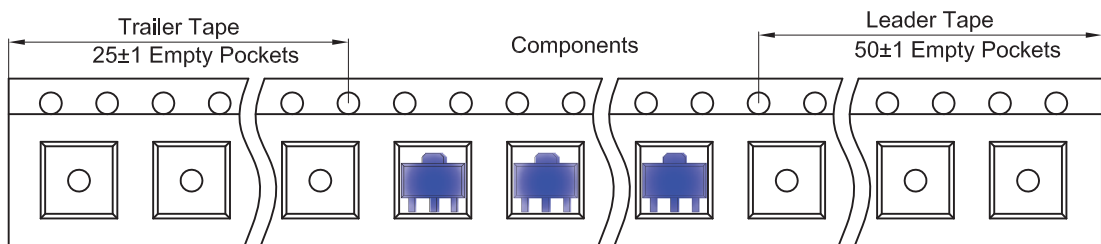

## SOT-89-3L Reel

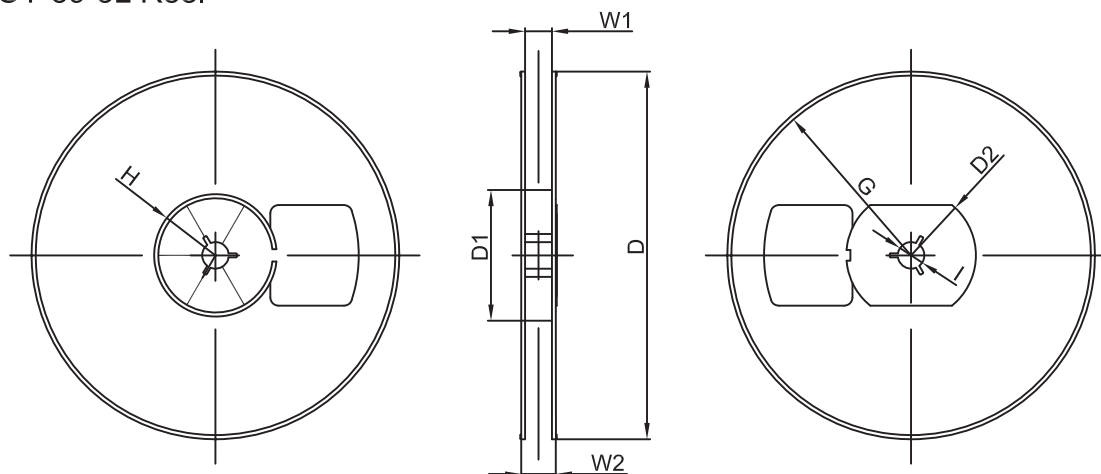

Dimensions are in millimeter								
Reel Option	D	D1	D2	G	H	I	W1	W2
7" Dia	Ø180.00	60.00	R32.00	R86.50	R30.00	Ø13.00	13.20	16.50

REEL	Reel Size	Box	Box Size(mm)	Carton	Carton Size(mm)	G.W.(kg)
1000 pcs	7 inch	10,000 pcs	203×203×195	40,000 pcs	438×438×220	

## TO-92 Package Outline Dimensions

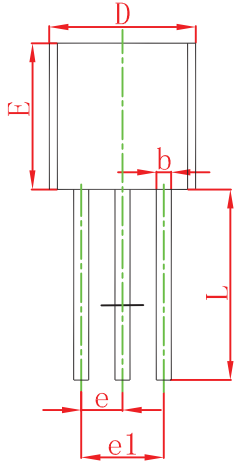
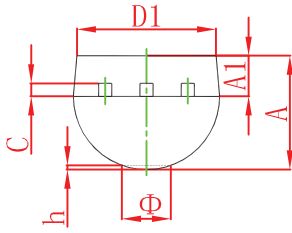

Symbol	Dimensions In Millimeters		Dimensions In Inches	
	Min	Max	Min	Max
A	3.300	3.700	0.130	0.146
A1	1.100	1.400	0.043	0.055
b	0.380	0.550	0.015	0.022
c	0.360	0.510	0.014	0.020
D	4.300	4.700	0.169	0.185
D1	3.430		0.135	
E	4.300	4.700	0.169	0.185
e	1.270 TYP		0.050 TYP	
e1	2.440	2.640	0.096	0.104
L	14.100	14.500	0.555	0.571
r		1.600		0.063
h	0.000	0.380	0.000	0.015

## TO-92 Suggested Pad Layout

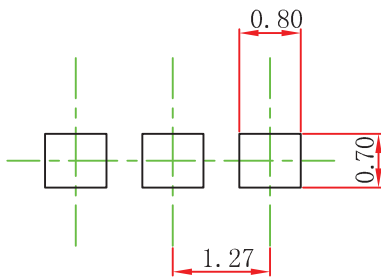

### Note:

1. Controlling dimension: in millimeters.
2. General tolerance:  $\pm 0.05$ mm.
3. The pad layout is for reference purposes only.

### NOTICE

JSCJ reserves the right to make modifications, enhancements, improvements, corrections or other changes without further notice to any product herein. JSCJ does not assume any liability arising out of the application or use of any product described herein.



TO-92 PACKAGE TAPEING DIMENSION

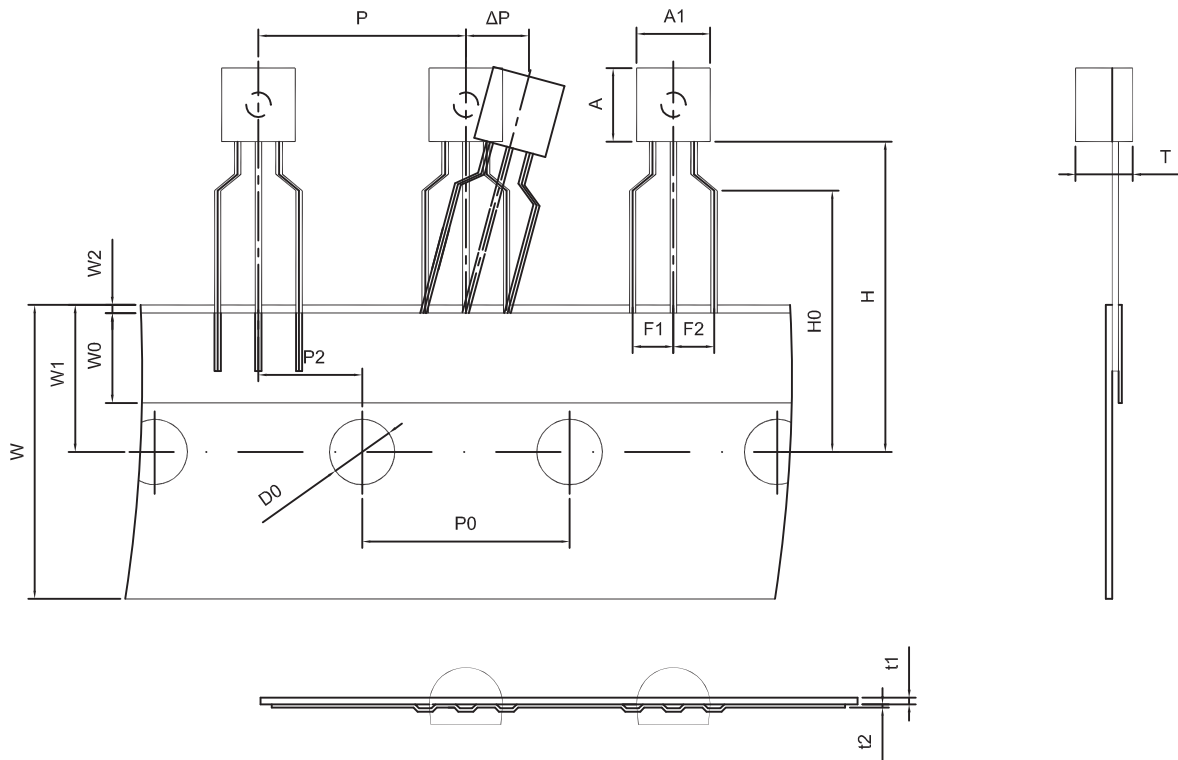

Dimiensions are in millimeter								
A1	A	T	P	P0	P2	F1	F2	W
4.5	4.5	3.5	12.7	12.7	6.35	2.5	2.5	18.0
W0	W1	W2	H	H0	D0	t1	t2	ΔP
6.0	9.0	1.0 MAX.	19.0	16.0	4.0	0.4	0.2	0

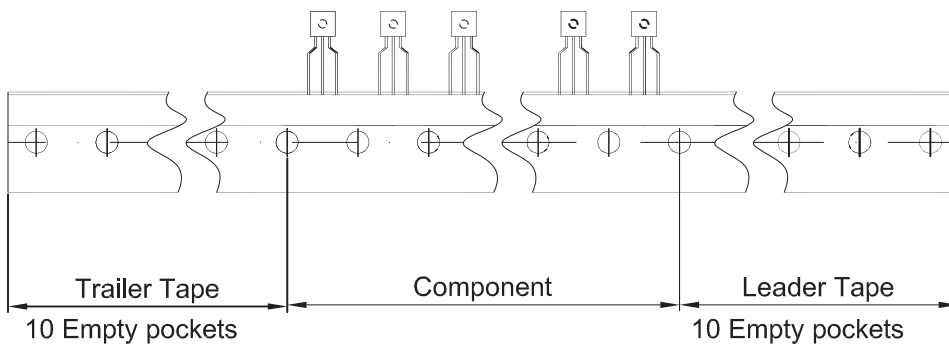

Package	Box	Box Size(mm)	Carton	Carton Size(mm)
TO-92	2000 pcs	333×162×43	20,000 pcs	350×340×250

单击下面可查看定价，库存，交付和生命周期等信息

[>>JSCJ](#)