

Power Top View LEDs with Lens 67-31EP3-URD1224EAGAZ7-ET0D-AM(TJB)



Features

Lead (Pb) Free Product - RoHS Compliant

- P-LCC-3 package.
- Colored diffused resin.
- Wide viewing angle 30°.
- Inner reflector and white package.
- Qualification according to AEC-Q101 rev C.
- Soldering methods: IR reflow soldering.
- Compliance with EU REACH

Applications

- Backlight: LCD, switches, symbol, mobile phone and illuminated advertising.
- Ideal for coupling into light guides.
- Substitution of traditional light.
- General applications.
- Optical indicator.
- Automotive

Device Selection Guide

Chip Materials	Emitted Color	Resin Color
AlGaInP	Reddish Orange	Diffused

Absolute Maximum Ratings (Ta=25°C)

Parameter	Symbol	Rating	Unit
Forward Current	I _F	70	mA
Power Dissipation	P _d	190	mW
Junction Temperature	T _j	125	°C
Operating Temperature	T _{opr}	-40 ~ +100	°C
Storage Temperature	T _{stg}	-40 ~ +110	°C
Thermal resistance	R _{th J-A}	500	K/W
	R _{th J-S}	300	K/W
ESD (Classification acc. AEC Q101)	ESD _{HBM}	2000	V
	ESD _{MM}	200	V
Soldering Temperature	T _{sol}	Reflow Soldering : 260 °C for 30 sec. Hand Soldering : 350 °C for 3 sec.	

Electro-Optical Characteristics (Ta=25°C)

Parameter	Symbol	Min.	Typ.	Max.	Unit	Condition
Luminous Intensity	I _v	7100	---	28000	mcd	I _F = 70mA
Viewing Angle	2θ _{1/2}	---	30	---	deg	
Dominant Wavelength	λ _d	612	---	624	nm	
Forward Voltage	V _F	1.8	---	2.6	V	V _R = 12V
Reverse Current	I _R	---	---	10	μA	

Note:

1. Tolerance of Luminous Intensity: ±11%
2. Tolerance of Dominant Wavelength: ±1nm
3. Tolerance of Forward Voltage: ±0.1V

Bin Range of Luminous Intensity

Bin Code	Min.	Max.	Unit	Condition
EA	7100	9000	mcd	I _F = 70mA
EB	9000	11200		
FA	11200	14400		
FB	14400	18000		
GA	18000	22400		
GB	22400	28000		

Bin Range of Dominant Wavelength

Bin Code	Min.	Max.	Unit	Condition
KJ-1	612.0	615.0	nm	I _F = 70mA
KJ-2	615.0	618.0		
KJ-3	618.0	621.0		
KJ-4	621.0	624.0		

Bin Range of Forward Voltage

Bin Code	Min.	Max.	Unit	Condition
G3-1	1.80	2.00	V	I _F =70mA
G3-2	2.00	2.20		
G3-3	2.20	2.40		
G3-4	2.40	2.60		

Typical Electro-Optical Characteristics Curves
Typical Curve of Spectral Distribution

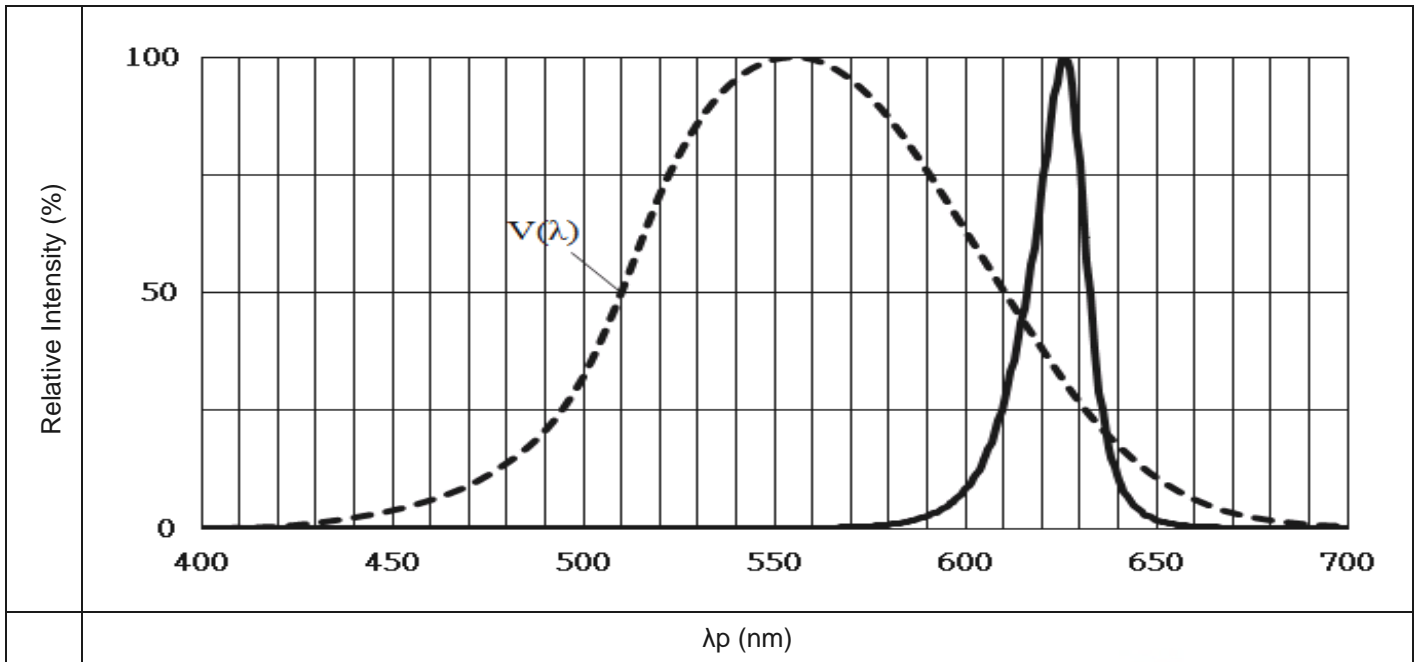

Note: V(λ)=Standard eye response curve;

Diagram Characteristics of Radiation

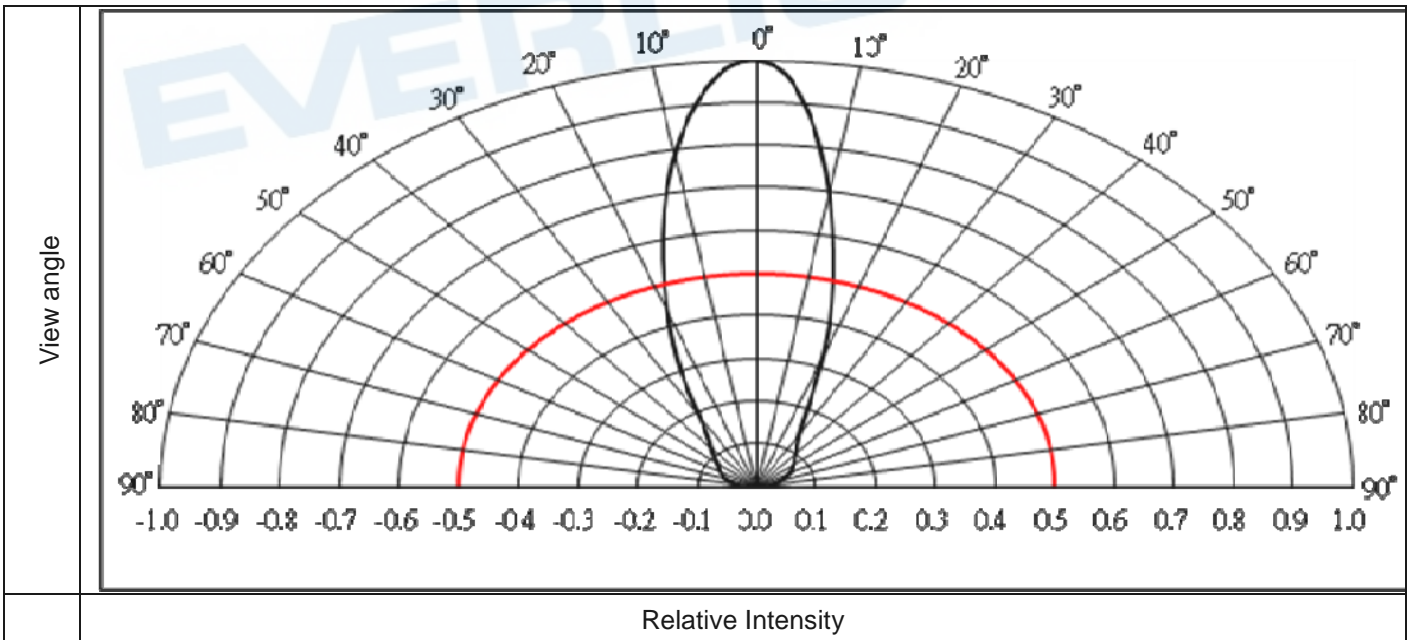

Typical Electro-Optical Characteristics Curves

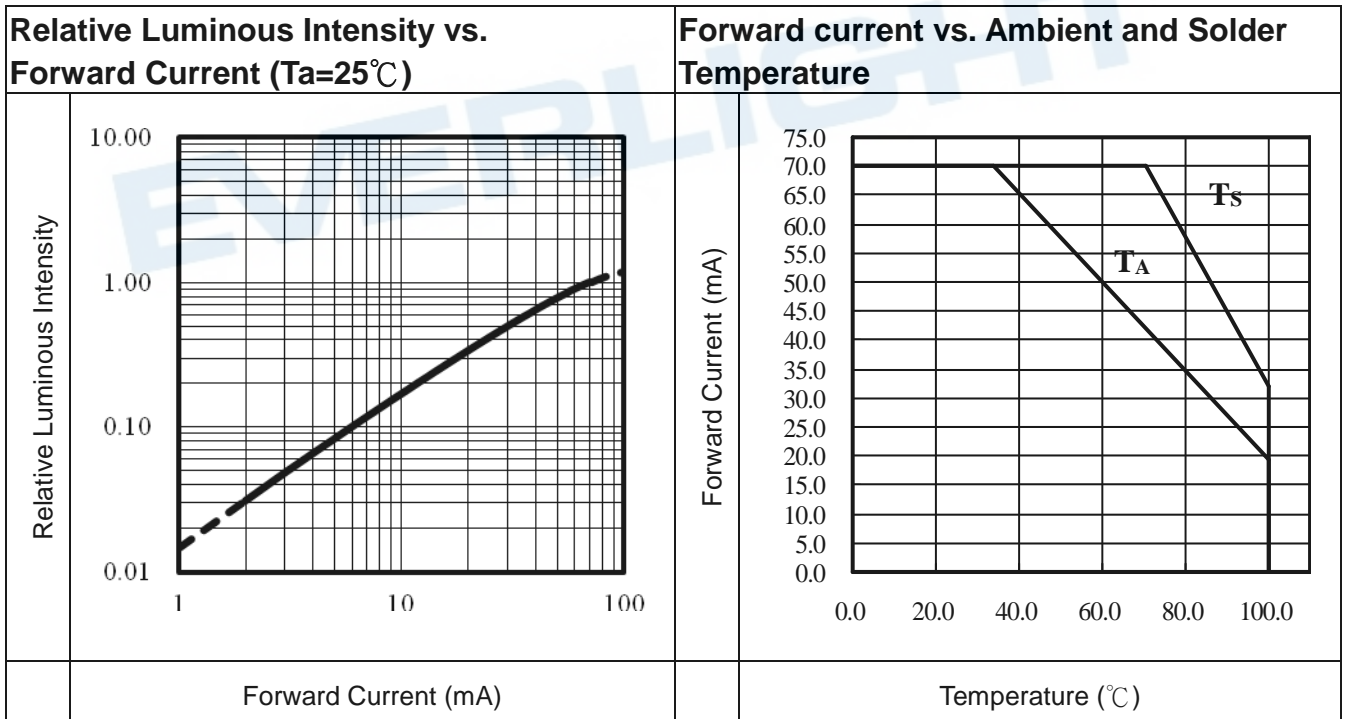
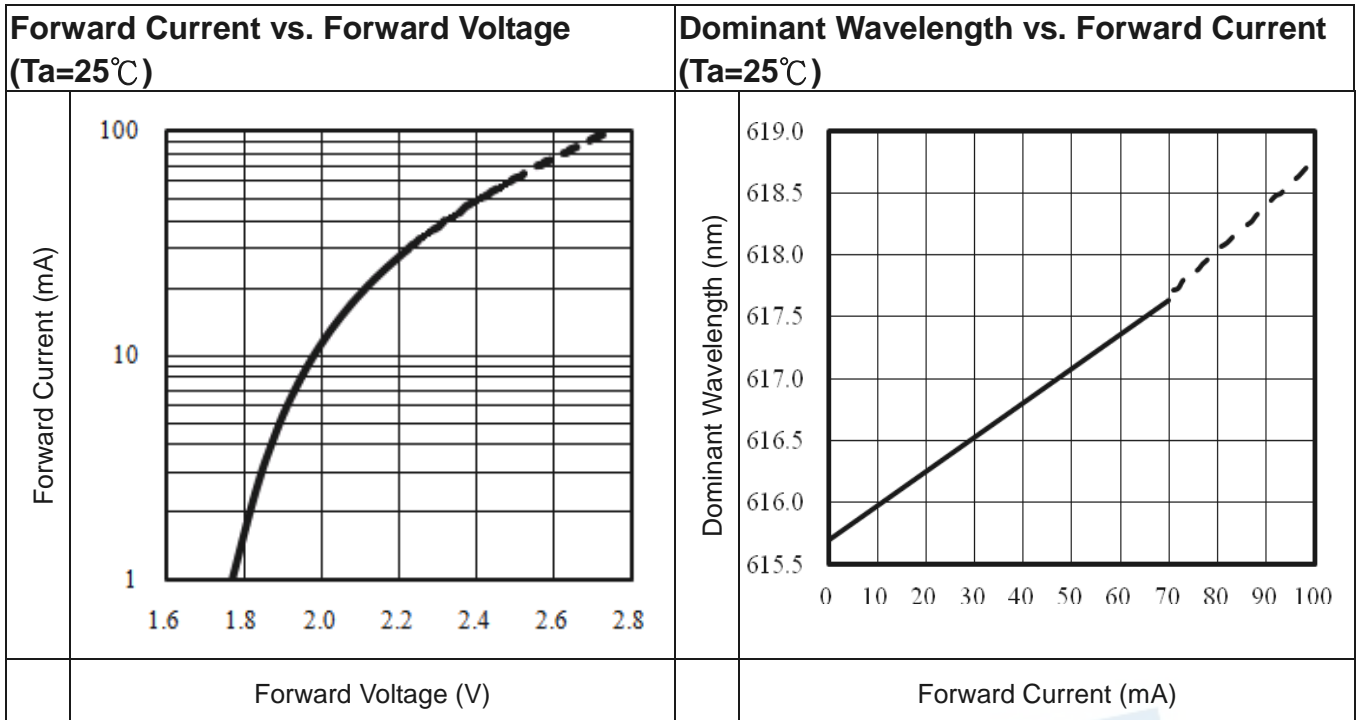

Package Dimension

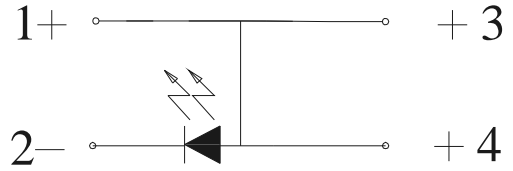
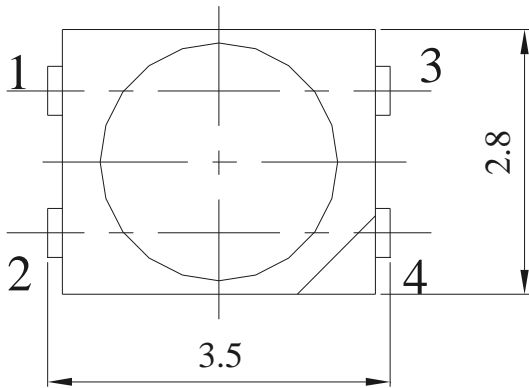

Polarity

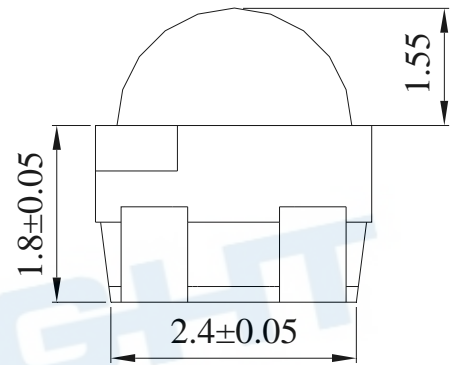
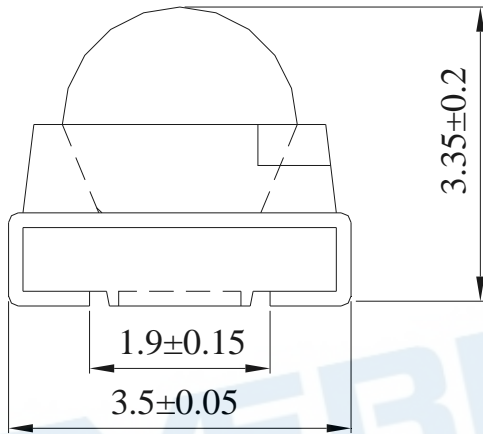

for reflow
 soldering (propose)

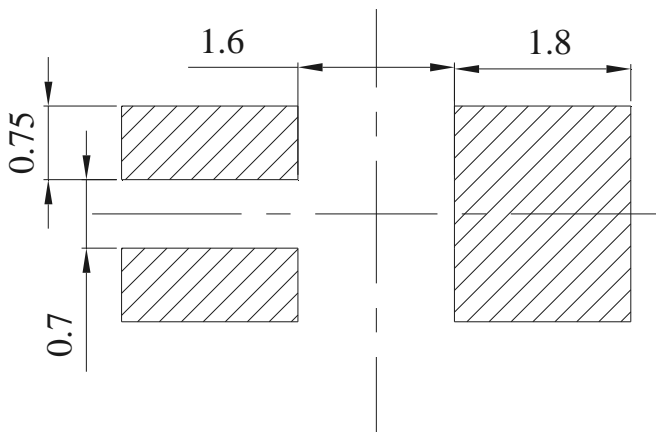
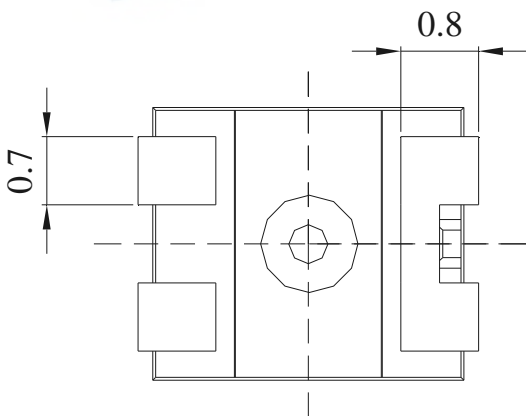

Note: Tolerances unless mentioned ± 0.1 mm. Unit = mm

Moisture Resistant Packing Materials

Label Explanation

- CPN: Customer's Product Number
- P/N: Product Number
- QTY: Packing Quantity
- CAT: Luminous Intensity Rank
- HUE: Dom. Wavelength Rank
- REF: Forward Voltage Rank
- LOT No: Lot Number

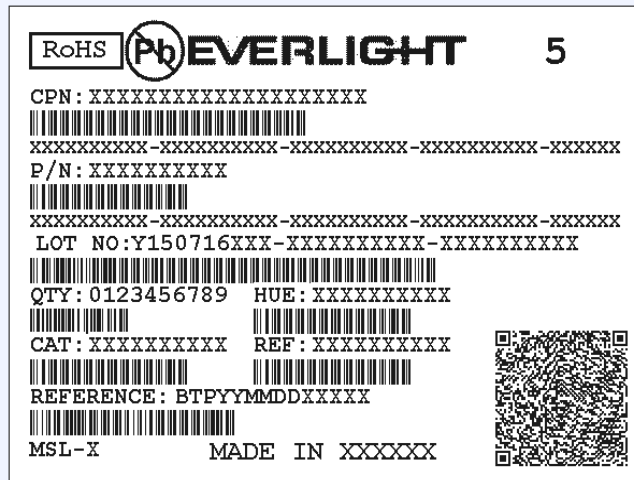

Reel Dimensions

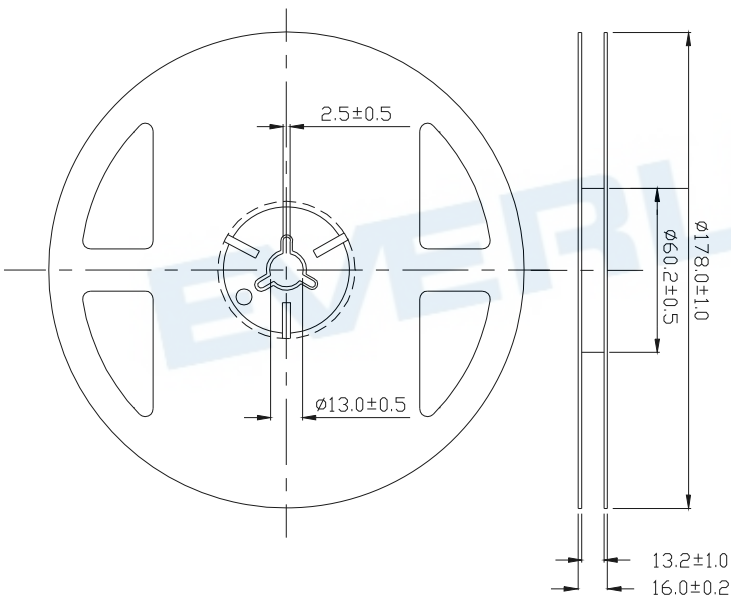

Note: Unit = mm

Carrier Tape Dimensions: Loaded Quantity 500 pcs Per Reel

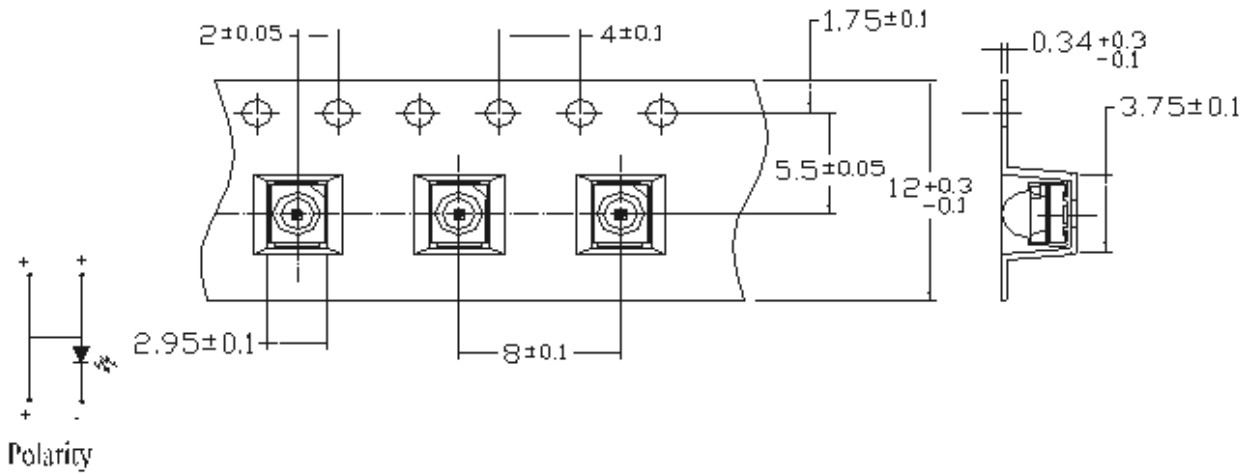

Note:
The tolerances unless mentioned is : ± 0.1 mm, Unit = mm

Moisture Resistant Packing Process

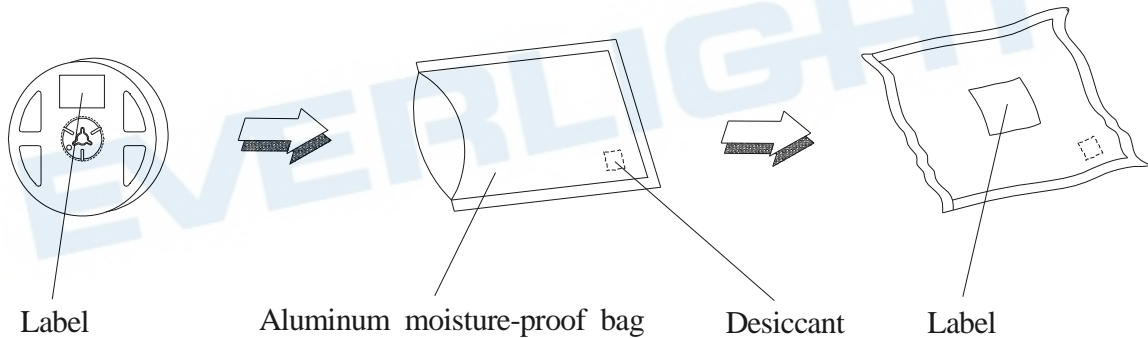

Note:
Tolerances unless mentioned ± 0.1 mm. Unit = mm

Precautions For Use

Precautions for Use

1. Soldering Condition (Reference: IPC/JEDEC J-STD-020D)

a. IR reflow

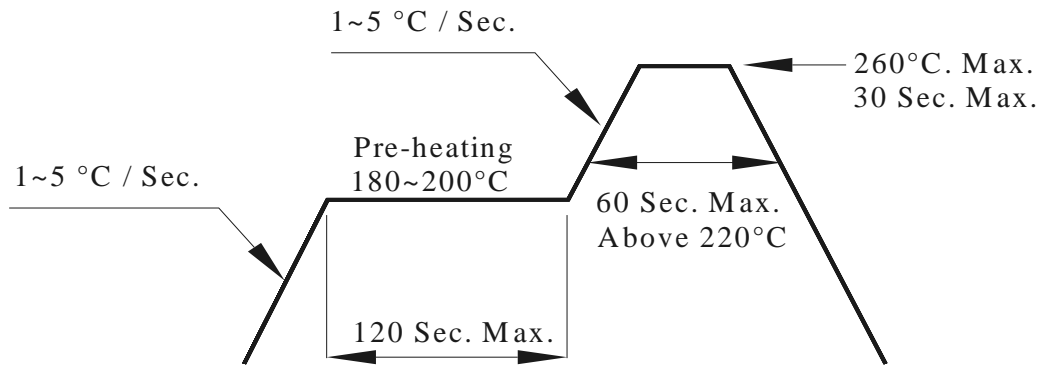

EVERLIGHT

(B) Recommend soldering pad

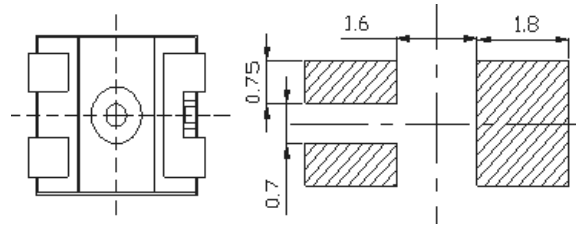

Note: Tolerances unless mentioned ± 0.1 mm. Unit = mm

2. Current limiting

A resistor should be used to limit current spikes that can be caused by voltage fluctuations. Otherwise damage could occur.

3. Storage

3.1 Moisture proof bag should only be opened immediately prior to usage.

3.2 Environment should be less than 30°C and 60% RH when moisture proof bag is opened.

3.3 After opening the package MSL Conditions stated on page 1 of this spec should not be exceeded.

3.4 If the moisture sensitivity card indicates higher than acceptable moisture, the component should be baked at min. 60deg +/-5deg for 24 hours.

4. Iron Soldering

Hand soldering is not recommended for regular production. These guidelines are for rework only. Soldering iron tip should contact each terminal no more than 3 sec at 350°C, using soldering iron with nominal power less than 25W. Allow min. 2 sec. between soldering intervals.

5. Usage

Do not exceed the values given in this specification.

Application Restrictions

High reliability applications such as military/aerospace, automotive safety/security systems, and medical equipment may require different product. If you have any concerns, please contact Everlight before using this product in your application. This specification guarantees the quality and performance of the product as an individual component. Do not use this product beyond the specification described in this document.

Revision History:

Rev.	Modified date	File modified contents
1	2017.07.14	New spec.
2	2017.09.10	Preliminary
3	2018.08.08	To add "GB"

EVERLIGHT

单击下面可查看定价，库存，交付和生命周期等信息

[>>Everlight \(亿光\)](#)