

## Data Sheet

Customer:	
Product:	Surge Withstanding Chip Resistor - SWR Series
Size:	0402/0603/0805/1206/1210/2010/2512
Issued Date:	15-Jun-22
Edition:	REV. B7



VIKING TECH CORPORATION  
光頡科技股份有限公司  
No.70 Guangfu N. Rd., Hukou  
Township, Hsinchu County 303,  
Taiwan

TEL:886-3-5972931  
FAX:886-3-5972935•886-3-5973494  
E-mail:sales@viking.com.tw

VIKING TECH CORPORATION KAOHSIUNG BRANCH  
光頡科技股份有限公司高雄分公司  
No.248-3, Sin-Sheng Rd., Cian-Jhen Dist., Kaohsiung,  
806, Taiwan

TEL:886-7-8217999  
FAX:886-7-8228229  
E-mail:sales@viking.com.tw

VIKING ELECTRONICS (WUXI) CO., LTD.  
光頡電子(無錫)有限公司  
No.22 Xixia Road, Machinery & Industry Park,  
National Hi-Tech Industrial Development Zone  
of Wuxi, Wuxi, Jiangsu Province, China  
Zip Code:214028  
TEL:86-510-85203339  
FAX:86-510-85203667•86-510-85203977  
E-mail:china@viking.com.tw

Produced by (QC)	Checked (QC)	Approved by (QC)	Prepared by (Sales)	Accepted by (Customer)
15-Jun-22	15-Jun-22	15-Jun-22		
<b>Alice Hsiao</b>	<b>Susan Huang</b>	<b>Susan Huang</b>		

## Surge Withstanding Chip Resistor – SWR Series

### ■ Features

- High power rating
- Excellent surge withstanding & pulse withstanding performance
- Improved working voltage ratings
- Standard package sizes of 0402~2512
- AEC-Q200 Compliance



### ■ Applications

- Metering (Testing/Measurement)
- Medical Devices
- Power supply
- Charger
- Inverter
- LCD Video Monitors

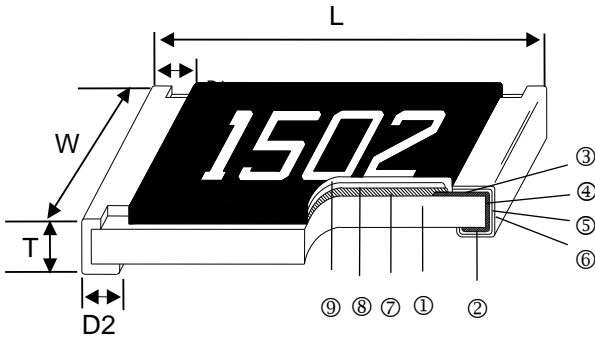

① Alumina Substrate	⑥ External Electrode
② Bottom Electrode	⑦ Resistor Layer
③ Top Electrode	⑧ Primary Overcoat
④ Edge Electrode	⑨ Secondary Overcoat
⑤ Barrier Layer	

### ■ Dimensions

Type	Size (Inch)	L (mm)	W (mm)	T (mm)	D1 (mm)	D2 (mm)	Weight (g) (1000pcs)
SWR02	0402	1.00±0.05	0.50±0.05	0.35±0.05	0.20±0.10	0.20±0.10	0.64
SWR03	0603	1.60±0.10	0.80±0.10	0.45±0.10	0.30±0.20	0.30±0.20	2.042
SWR05	0805	2.00±0.10	1.25±0.10	0.50±0.10	0.35±0.20	0.40±0.20	4.368
SWR05(1/2W)	0805	2.00±0.10	1.25±0.10	0.50±0.10	0.35±0.20	0.40±0.20	5.049
SWR06	1206	3.10±0.10	1.55±0.10	0.55±0.10	0.50±0.25	0.50±0.20	8.947
SWR06(3/4W)	1206	3.10±0.10	1.55±0.10	0.55±0.10	0.50±0.25	0.50±0.20	9.541
SWR13	1210	3.10±0.10	2.60±0.15	0.55±0.10	0.50±0.25	0.50±0.20	15.959
SWR10	2010	5.00±0.10	2.50±0.15	0.55±0.10	0.60±0.25	0.50±0.20	24.241
SWR12	2512	6.35±0.10	3.10±0.15	0.55±0.10	0.60±0.25	0.50±0.20	39.448
SWR12(2W)	2512	6.35±0.20	3.15±0.15	0.60±0.10	0.60±0.25	0.60±0.20	42

### ■ Derating Curve

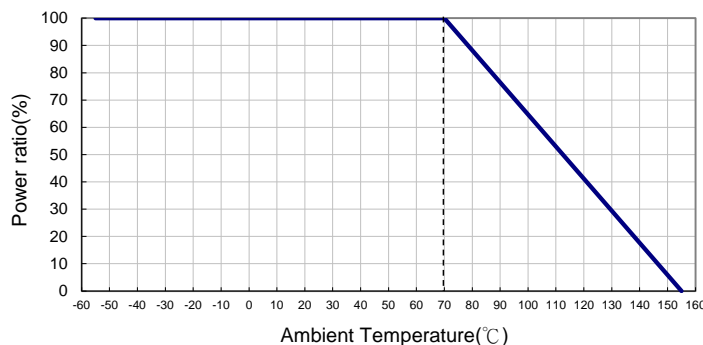

**Surge Withstanding Chip Resistor**

**Part Numbering**

SWR	05	J	T	E	V	1001	
Product Type	Dimensions	Resistance Tolerance	Packaging Code	TCR (PPM/°C)	Power Rating	Resistance	Marking
	02: 0402 03: 0603 05: 0805 06: 1206 13: 1210 10: 2010 12: 2512	J: ±5% K: ±10% M: ±20%	T: 7" Taping Reel V: 10" Taping Reel W: 13" Taping Reel	E: ±100 F: ±200 G: ±300 4: ±350	A: 1.5W T: 1W Q: 3/4W U: 1/2W G: 2/5W O: 1/3W V: 1/4W W: 1/8W P: 1/5W S: 2W	1001: 1KΩ 1004: 1MΩ 1005: 10MΩ	: Standard Marking N: No Marking

**Soldering Condition (Ref. IPC/JEDEC J-STD-020 & J-STD-002)**

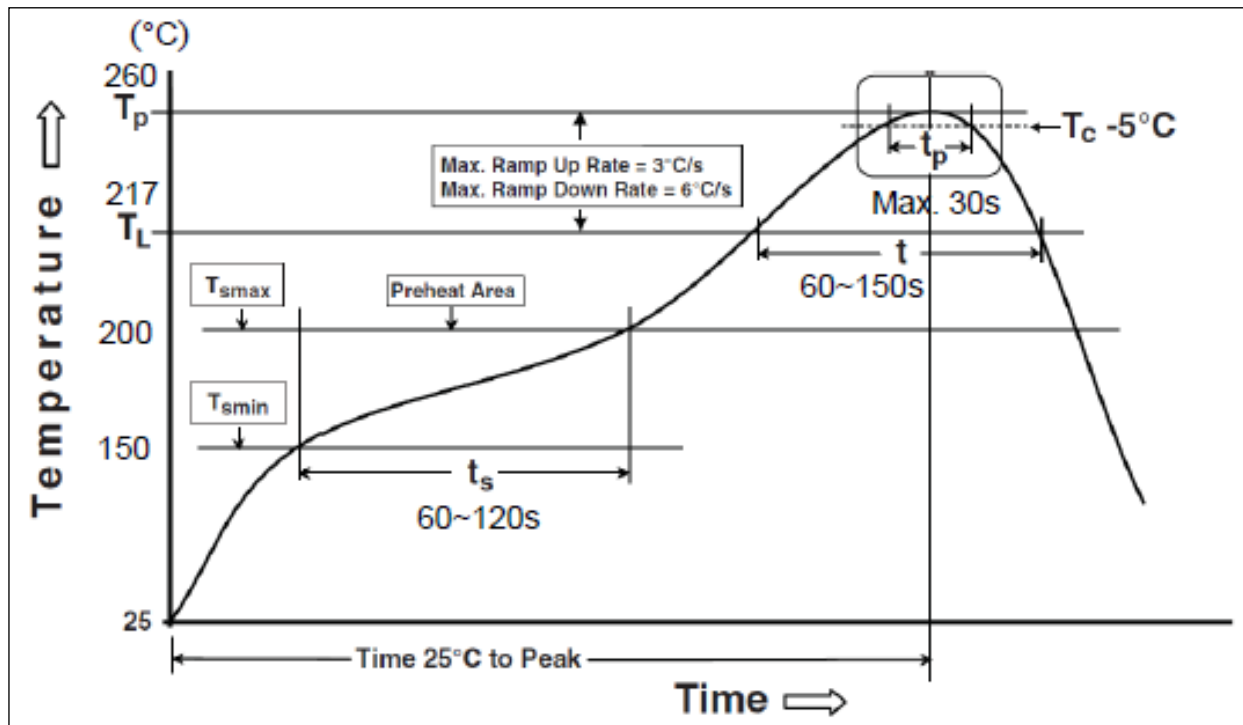

Reflow Profiles	
Profile Feature	Pb-Free Assembly
<b>Preheat</b> Min. Temperature (T <sub>smin</sub> ) Max Temperature (T <sub>smax</sub> ) Preheating time (t <sub>s</sub> ) from (T <sub>smin</sub> to T <sub>smax</sub> )	150 °C 200 °C 60-120 seconds
Ramp-up rate (T <sub>L</sub> to T <sub>p</sub> )	3 °C/second max.
Liquidous temperature (T <sub>L</sub> ) Time (t <sub>L</sub> ) maintained above T <sub>L</sub>	217 °C 60-150 seconds
Min. Peak temperature (T <sub>p</sub> min)	235°C
Max. Peak temperature (T <sub>p</sub> max)	260°C
Time (t <sub>p</sub> ) within 5 °C of the specified classification temperature (T <sub>c</sub> )	30 seconds max.
Ramp-down rate (T <sub>p</sub> to T <sub>L</sub> )	6 °C/second max.
Time 25 °C to peak temperature	8 minutes max.

**■ Standard Electrical Specifications**

Item Type	Power Rating at 70°C	Operating Temp. Range	Max. Operating Voltage	Max. Overload Voltage	Resistance Range(E24)			TCR (PPM/°C)
					±5%	±10%	±20%	
SWR02 (0402)	1/5W	-55 ~ +155°C	50V	100V	1Ω - 20Ω			±300
					22Ω - 1MΩ			±100
SWR03 (0603)	1/8W	-55 ~ +155°C	50V	100V	10Ω - 270Ω			±200
					300Ω - 1MΩ			±100
SWR05 (0805)	1/4W	-55 ~ +155°C	150V	300V	1Ω - 270Ω			±200
					300Ω - 20MΩ			±100
SWR06 (1206)	1/3W	-55 ~ +155°C	200V	400V	1Ω - 20Ω			±200
					22Ω - 20MΩ			±100
SWR13 (1210)	1/2W	-55 ~ +155°C	200V	400V	1Ω - 20Ω			±200
					22Ω - 20MΩ			±100
SWR10 (2010)	3/4W	-55 ~ +155°C	400V	800V	1Ω - 20Ω			±200
					22Ω - 20MΩ			±100
SWR12 (2512)	1.5W	-55 ~ +155°C	500V	1000V	1Ω - 20Ω			±200
					22Ω - 20MΩ			±100

**■ High Power & Ultra High Power Rating Electrical Specifications**

Item Type	Power Rating at 70°C	Operating Temp. Range	Max. Operating Voltage	Max. Overload Voltage	Resistance Range (E24)			TCR (PPM/°C)
					±5%	±10%	±20%	
SWR03 (0603)	1/4W	-55 ~ +155°C	75V	150V	10Ω - 270Ω			±200
					300Ω - 1MΩ			±100
SWR05 (0805)	2/5W	-55 ~ +155°C	150V	300V	1Ω - 270Ω			±200
					300Ω - 1MΩ			±100
SWR05 (0805)	1/2W *	-55 ~ +155°C	400V	600V	1Ω - 270Ω			±200
					300Ω - 1MΩ			±100
SWR06 (1206)	1/2W	-55 ~ +155°C	200V	400V	1Ω - 20Ω			±200
					22Ω - 1MΩ			±100
SWR06 (1206)	3/4W *	-55 ~ +155°C	500V	1000V	1Ω - 20Ω			±200
					22Ω - 1MΩ			±100
SWR13 (1210)	3/4W	-55 ~ +155°C	200V	400V	1Ω - 20Ω			±200
					22Ω - 1MΩ			±100
SWR10 (2010)	1W	-55 ~ +155°C	400V	800V	1Ω - 20Ω			±200
					22Ω - 1MΩ			±100
SWR12 (2512)	2W *	-55 ~ +155°C	500V	1000V	1Ω - 10Ω			±350
					11Ω - 200KΩ			±100

\*: Ultra High Power: double side printed resistor element

Operating Voltage= $\sqrt{P \cdot R}$  or Max. Operating Voltage listed above, whichever is lower.

Overload Voltage= $2.5 \cdot \sqrt{P \cdot R}$  or Max. Overload Voltage listed above, whichever is lower.

The power rating depends on the maximum temperature of the resistive element. Due to the power dissipation of the resistor, the temperature of the resistive element will rise depending on the condition of heat dissipation from PCB. The maximum power rating in application only applies if the temperature of the resistive element is not exceed 155 °C.

■ Viking is capable of manufacturing the optional spec based on customer's requirement.

**■ Environmental Characteristics**

Item	Requirement	Test Method
Temperature Coefficient of Resistance (T.C.R.)	As Spec.	<b>JIS-C-5201-1 4.8</b> <b>IEC-60115-1 4.8</b> At 25°C/-55°C and 25°C/+125°C, 25°C is the reference temperature
Short Time Overload	±(1.0%+0.05Ω)	<b>JIS-C-5201-1 4.13</b> <b>IEC-60115-1 4.13</b> RCWV*2.5 or Max. Overload Voltage whichever is lower for 5 seconds
Insulation Resistance	≥10G	<b>JIS-C-5201-1 4.6</b> <b>IEC-60115-1 4.6</b> Max. Overload Voltage for 1 minute
Endurance	±(3.0%+0.05Ω)	<b>JIS-C-5201-1 4.25</b> <b>IEC-60115-1 4.25.1</b> 70±2°C, RCWV for 1000 hrs with 1.5 hrs "ON" and 0.5 hr "OFF"
Damp Heat with Load	±(3.0%+0.05Ω)	<b>JIS-C-5201-1 4.24</b> <b>IEC-60115-1 4.24</b> 40±2°C, 90~95% R.H., RCWV for 1000 hrs with 1.5 hr "ON" and 0.5 hrs "OFF"
Dry Heat	±(3.0%+0.05Ω)	<b>JIS-C-5201-1 4.23</b> <b>IEC-60115-1 4.23.2</b> at +155°C for 1000 hrs
Bending Strength	±(1.0%+0.05Ω)	<b>JIS-C-5201-1 4.33</b> <b>IEC-60115-1 4.33</b> Bending once for 60 seconds 2010, 2512 sizes: 2mm Other sizes: 3mm
Solderability	95% min. coverage	<b>JIS-C-5201-1 4.17</b> <b>IEC-60115-1 4.17</b> 245±5°C for 3 seconds
Resistance to Soldering Heat	±(1.0%+0.05Ω)	<b>JIS-C-5201-1 4.18</b> <b>IEC-60115-1 4.18</b> 260±5°C for 10 seconds
Voltage Proof	No breakdown or flashover	<b>JIS-C-5201-1 4.7</b> <b>IEC-60115-1 4.7</b> 1.42 times Max. Operating Voltage for 1 minute
Leaching	Individual leaching area ≤5% Total leaching area ≤ 10%	<b>JIS-C-5201-1 4.18</b> <b>IEC-60068-2-58 8.2.1</b> 260±5°C for 30 seconds
Rapid Change of Temperature	±(1.0%+0.05Ω)	<b>JIS-C-5201-1 4.19</b> <b>IEC-60115-1 4.19</b> -55°C to +155°C, 5 cycles

RCWV(Rated Continuous Working Voltage)=√(P\*R) or Max. Operating Voltage whichever is lower.

**■ Storage Temperature: 15~28°C; Humidity < 80%RH**

**■ Shelf Life: 2 years from production date**

**■Packaging**

Reel Specifications & Packaging Quantity

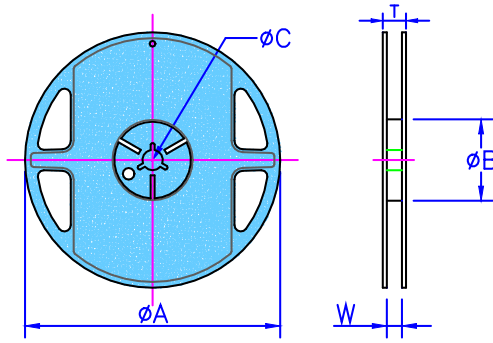

Type	Packaging Quantity	Tape Width	Reel Diameter	øA (mm)	øB (mm)	øC (mm)	W (mm)	T (mm)
SWR02	Paper	10K	7 inch	178.5±1.5	60 <sup>+1/-0</sup>	13.0±0.2	9.0±0.5	12.5±0.5
		20K	10 inch	254±1.0	100±0.5	13.0±0.2	9.5±0.5	13.5±0.5
		40K	13 inch	330±1.0	100±0.5	13.0±0.2	9.5±0.5	13.5±0.5
SWR03 SWR05 SWR06 SWR13	Paper	5K	7 inch	178.5±1.5	60 <sup>+1/-0</sup>	13.0±0.2	9.0±0.5	12.5±0.5
		10K	10 inch	254±1.0	100±0.5	13.0±0.2	9.5±0.5	13.5±0.5
		20K	13 inch	330±1.0	100±0.5	13.0±0.2	9.5±0.5	13.5±0.5
SWR10 SWR12	Embossed	4K	7 inch	178.5±1.5	60 <sup>+1/-0</sup>	13.0±0.5	13.0±0.5	15.5±0.5
		8K	10 inch	250±1.0	62±0.5	13.0±0.5	12.5±0.5	16.5±0.5

Paper Tape Specifications

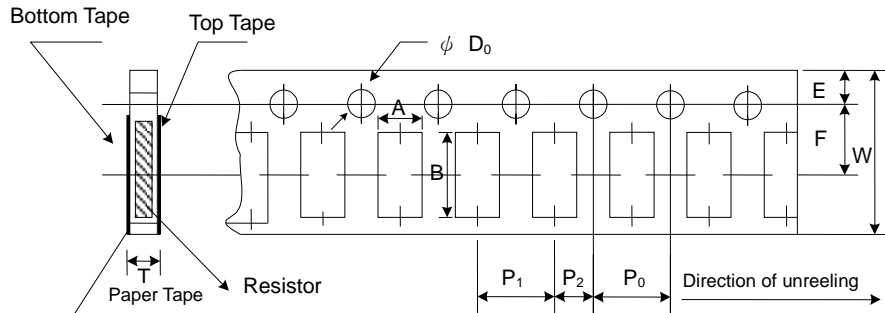

Type	A (mm)	B (mm)	W (mm)	E (mm)	F (mm)	P <sub>0</sub> (mm)	P <sub>1</sub> (mm)	P <sub>2</sub> (mm)	øD <sub>0</sub> (mm)	T (mm)
SWR02	0.65±0.10	1.15±0.10	8.00±0.2	1.75±0.1	3.50±0.05	4.00±0.10	2.00±0.05	2.00±0.05	1.50+0.1,-0	0.45±0.1
SWR03	1.10±0.10	1.90±0.1	8.00±0.2	1.75±0.1	3.50±0.05	4.00±0.10	4.00±0.05	2.00±0.05	1.50+0.1,-0	0.70±0.1
SWR05	1.60±0.10	2.40±0.2	8.00±0.2	1.75±0.1	3.50±0.05	4.00±0.10	4.00±0.05	2.00±0.05	1.50+0.1,-0	0.85±0.1
SWR06	1.90±0.10	3.50±0.2	8.00±0.2	1.75±0.1	3.50±0.05	4.00±0.10	4.00±0.05	2.00±0.05	1.50+0.1,-0	0.85±0.1
SWR13	2.90±0.10	3.50±0.2	8.00±0.2	1.75±0.1	3.50±0.05	4.00±0.10	4.00±0.05	2.00±0.05	1.50+0.1,-0	0.85±0.1

Embossed Plastic Tape Specifications

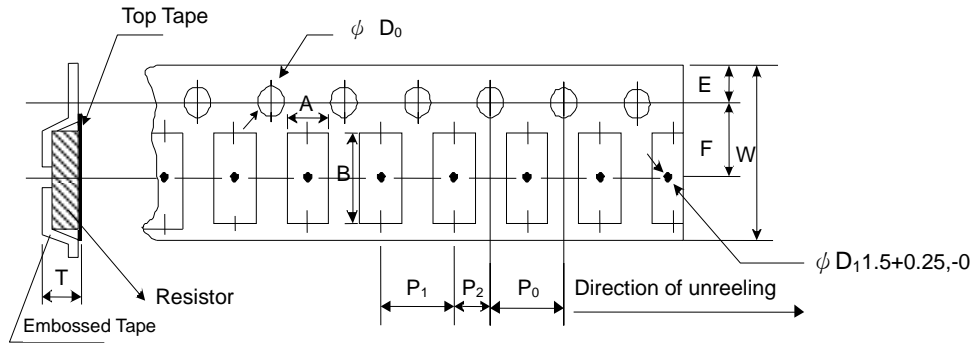

Type	A (mm)	B (mm)	W (mm)	E (mm)	F (mm)	P <sub>0</sub> (mm)	P <sub>1</sub> (mm)	P <sub>2</sub> (mm)	ΦD <sub>0</sub> (mm)	T (mm)
SWR10	2.80±0.10	5.40±0.20	12.0±0.3	1.75±0.1	5.5±0.05	4.00±0.10	4.00±0.1	2.00±0.05	1.50+0.1, -0	1.2 <sup>+0</sup>
SWR12	3.50±0.10	6.70±0.10	12.0±0.3	1.75±0.1	5.5±0.05	4.00±0.10	4.00±0.1	2.00±0.05	1.50+0.1, -0	1.2 <sup>+0</sup>

**■ Marking**

No Marking for 0402

0805~2512 4 digits marking for Example

Resistance	100Ω	2.2KΩ	10KΩ	100KΩ	1MΩ
Marking	1000	2201	1002	1003	1004

0603: 3 digits marking in E24

Example: 101=100Ω 102=1KΩ (1<sup>st</sup> and 2<sup>nd</sup> are E24 code and 3<sup>rd</sup> code is multiplier)

E24 code	10	11	12	13	15	16	18	20	22	24	27	30	33	36	39	43	47	51	56	62	68	75	82	91

**■ Recommend Land Pattern**

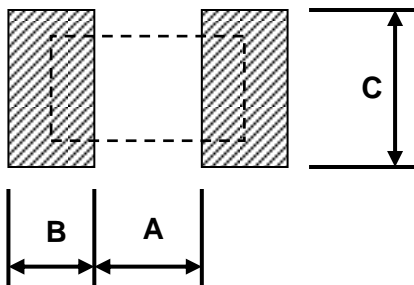

Type	A (mm)	B (mm)	C (mm)
SWR02	0.50	0.45	0.60
SWR03	0.90	0.60	0.90
SWR05	1.20	0.70	1.30
SWR06	2.00	0.90	1.60
SWR13	2.00	0.90	2.80
SWR10	3.80	0.90	2.80
SWR12	4.90	1.00	3.40

**Lightning Surge**

Resistors are tested in accordance with IEC 60115-1 using both 1.2/50us and 10/700 pulse shapes. The limit of acceptance is a shift in resistance of less than 1% from the initial value.

SWR Series 1.2/50us Lightning Surge

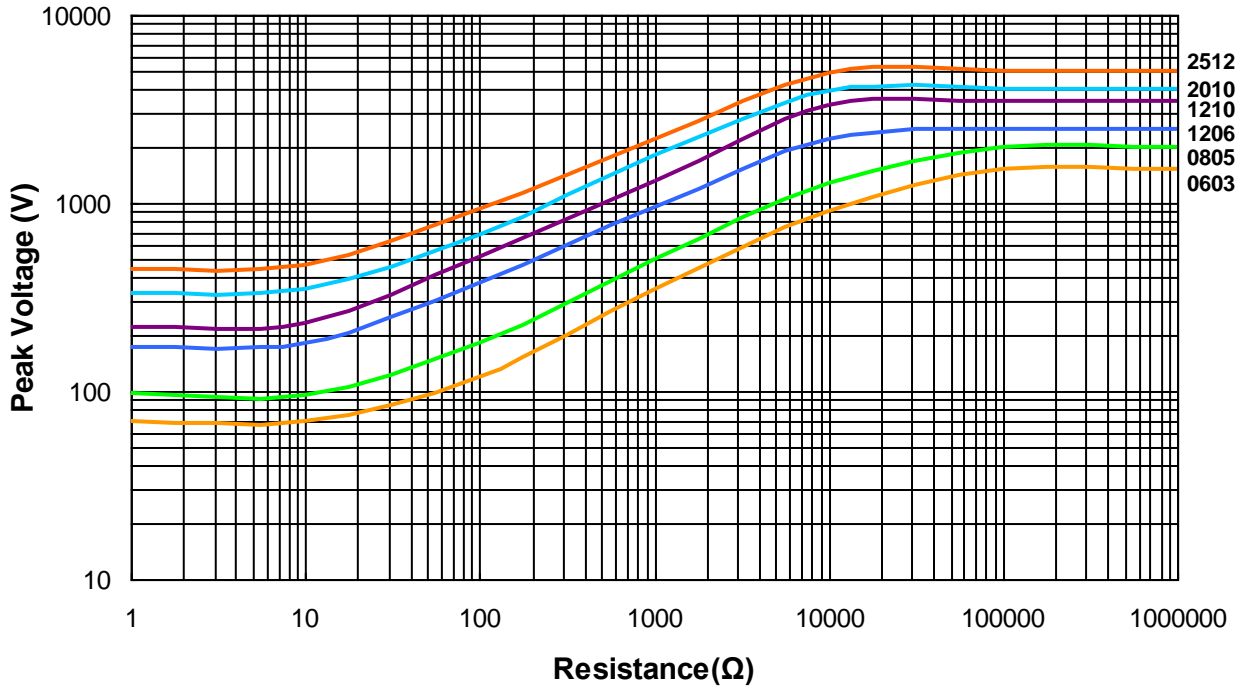

SWR Series 10/700us Lightning Surge

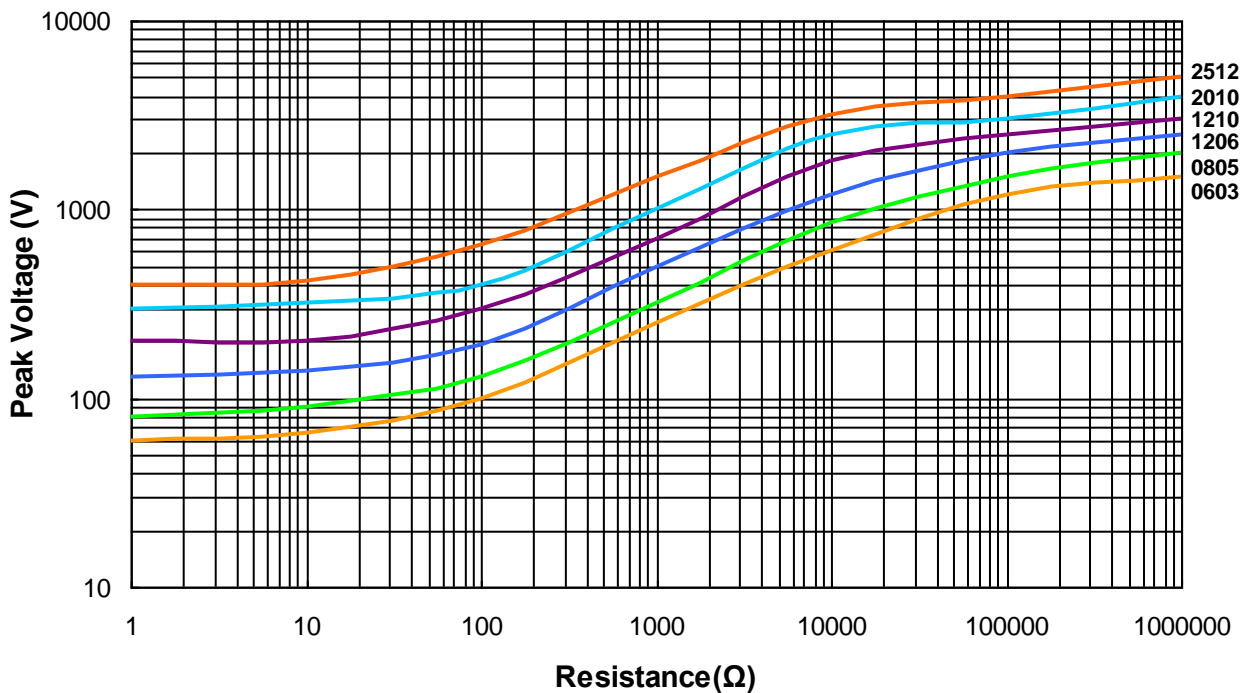



### ■ Pulse withstanding capacity

The limit of acceptance was a shift in resistance of less than 1% from the initial value. The power applied was subject to the restrictions of the maximum permissible impulse voltage graph shown.

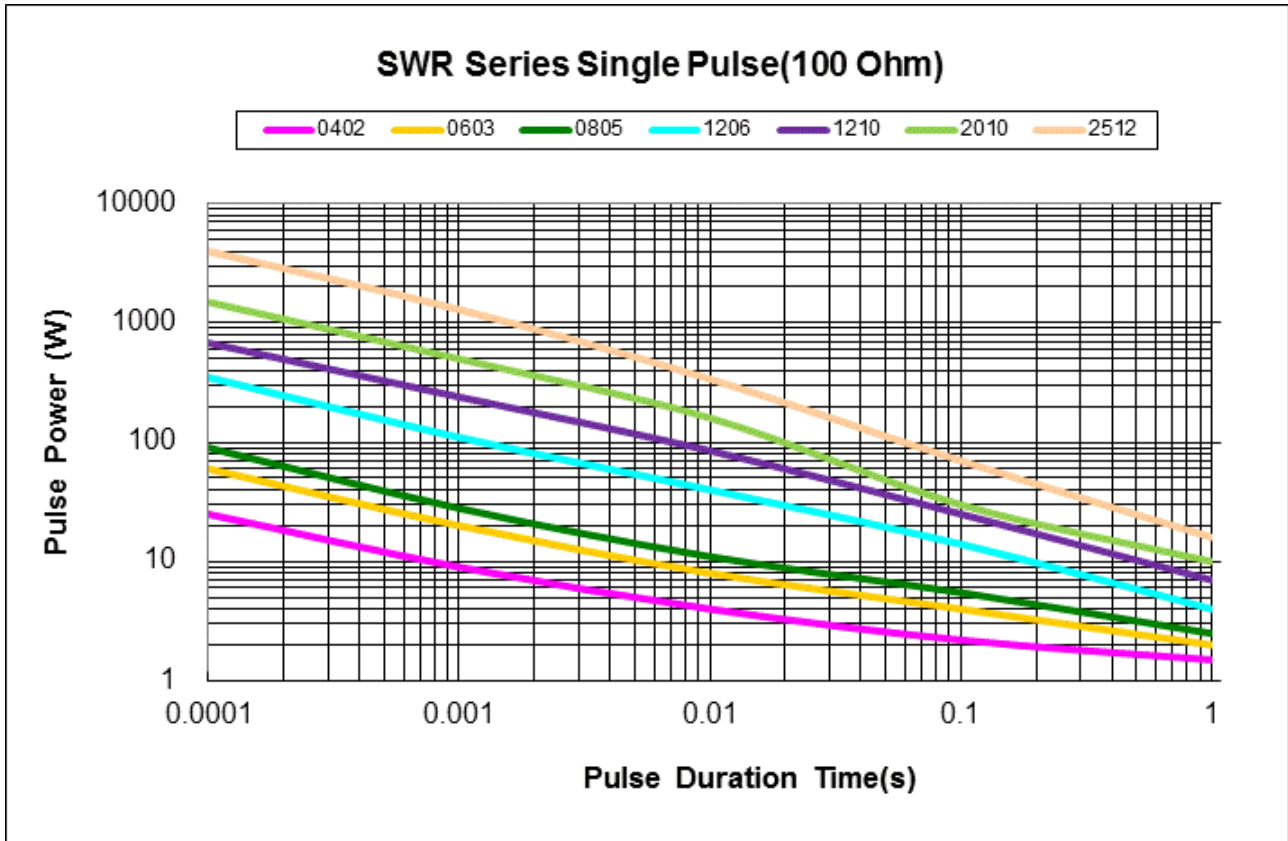

**Continuous Pulse**

The continuous load graph was obtained by applying repetitive rectangular pulses where the pulse period was adjusted so that the average power dissipated in the resistor was equal to its rated power at 70°C. Again the limit of acceptance was a shift in resistance of less than 1% from the initial value.

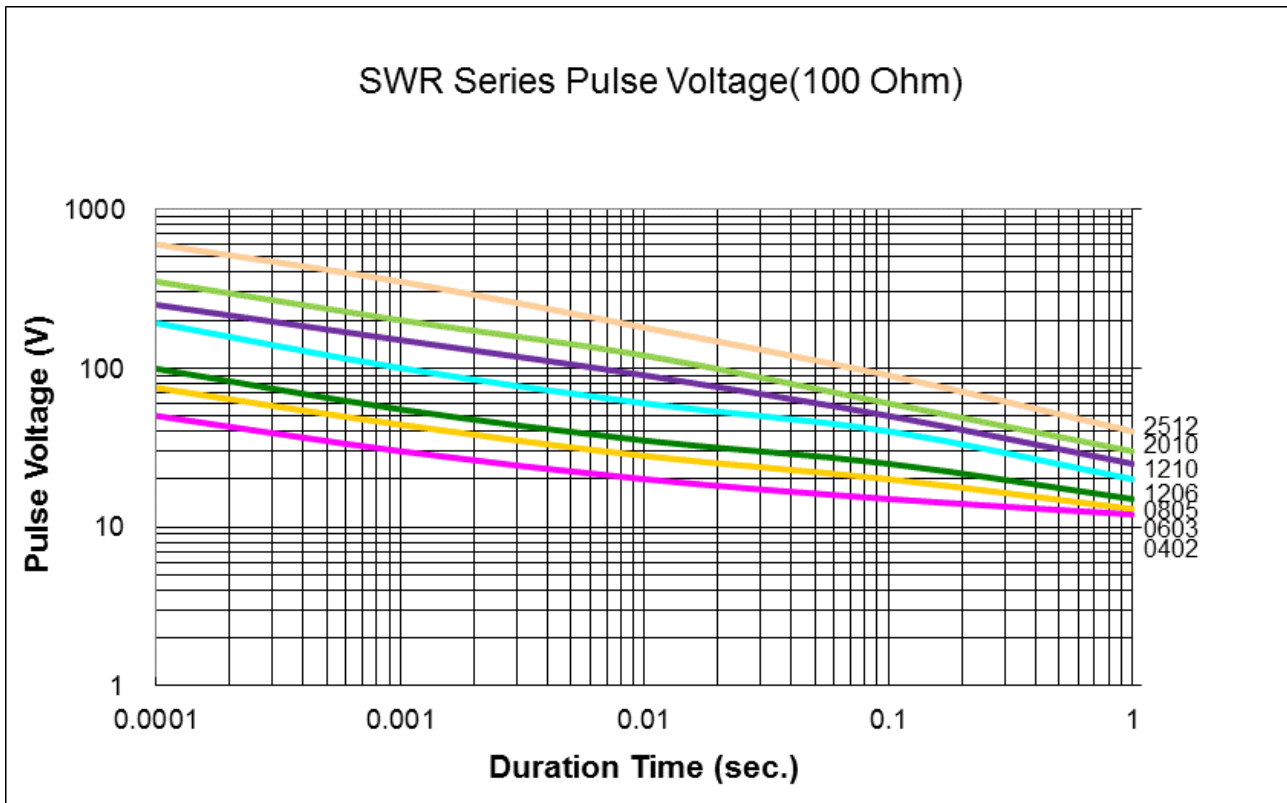
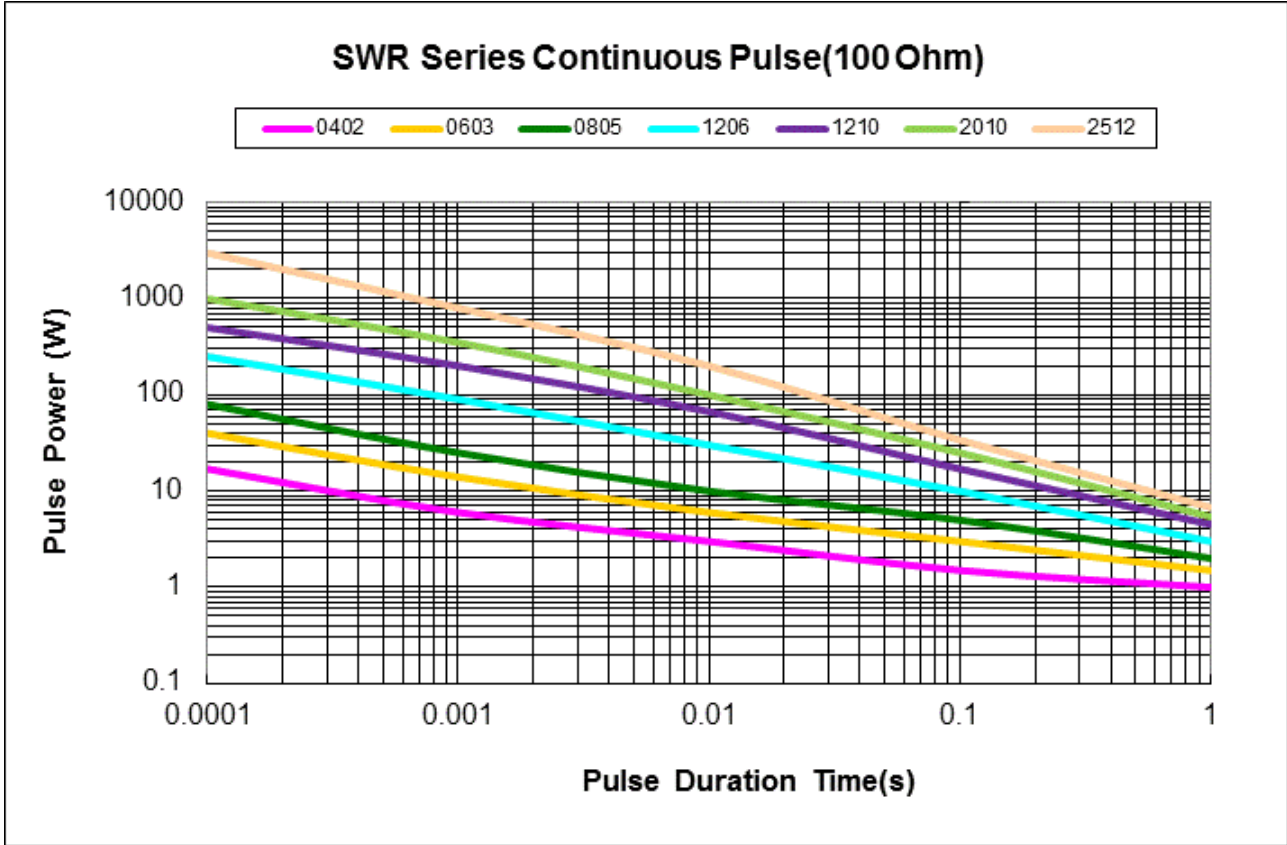

**REVISION HISTORY**

REVISION	DATE	CHANGE NOTIFICATION	DESCRIPTION
Version A8	Jun 03, 2014	-	- Environmental Characteristics updated
Version A9	Jul 15, 2016	-	- Remove Material Description - Modify Storage Temperature
Version B	Oct 13, 2017	-	- Increase High Power Specifications
Version B1	Jul 27, 2018	-	- Increase 0402 size Electrical Specifications - Increase 0805/1206 Ultra High Power Electrical Specifications
Version B2	May 20, 2019	-	- Modify TCR Test description
Version B3	Jan 31, 2020	-	- Increase SWR2512 2W
Version B4	Mar 10, 2021	-	- Modify Bending Test description - Increase large reel packaging code - Modify 2010 Embossed Plastic Tape B Specification - Modify Soldering Condition (IPC/JEDEC J-STD-020)
Version B5	Nov 15, 2021	-	- Increase the shelf life description
Version B6	Feb 15, 2022	-	- Derating Curve changes the temperature range
Version B7	Jun 15, 2022	-	- Modify Soldering Condition

单击下面可查看定价，库存，交付和生命周期等信息

[>>VIKING\(光颧\)](#)