



SILERGY

SY6863B3

5.5V, 3A Low Loss Power Distribution Switch with Reverse Block Rating Up to 28V

General Description

SY6863B3 is an ultra-low $R_{DS(ON)}$, 3A Low Loss power distribution switch with current limit to protect the power source from over current and short circuit conditions.

SY6863B3 has over voltage protection and the output pin can withstand 28V. It incorporates the over-temperature protection and reverse blocking functions.

SY6863B3 supports USB PD3.0 fast role swap. The output voltage can recover to USB valid voltage range within 110 μ s during USB PD fast role swap event.

Ordering Information

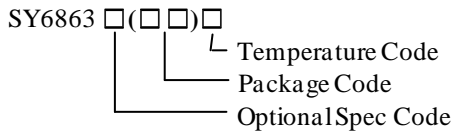

Ordering Number	Package Type	Note
SY6863B3ABC	SOT23-6	Active High

Features

- Input Voltage: 2.5V to 5.5V
- Output Voltage Withstanding 28V
- Extremely Low Power Path Resistance: 45m Ω (typ.)
- 3A Load Current Capability
- Reverse Blocking in Normal Operation or Shutdown
- Fault Flag (OCB) Output For Over Current and Fault Conditions
- Fast Role Swap Support
- Compact Package: SOT23-6
- RoHS Compliant and Halogen Free

Applications

- USB 3.1 Application
- USB 3G Datacard
- USB Dongle
- MiniPCI Accessories
- USB Charger
- Public Place Multi-USB Charger

Typical Applications

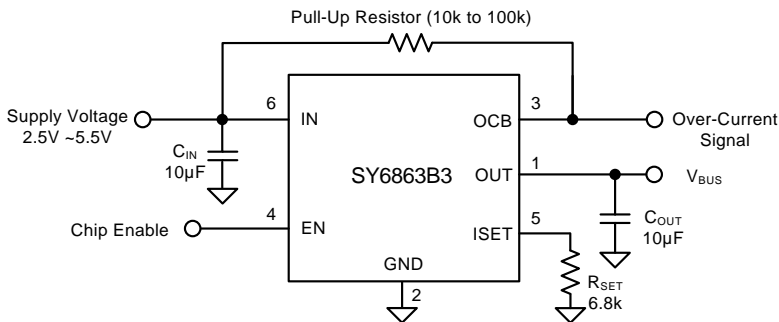

Note: If 1uF input cap will lead to large Vin voltage spike, it is strongly recommended to add additional 10uF ceramic cap.

Figure1. Schematic Diagram

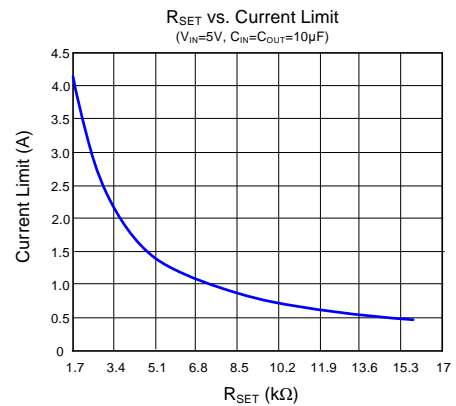
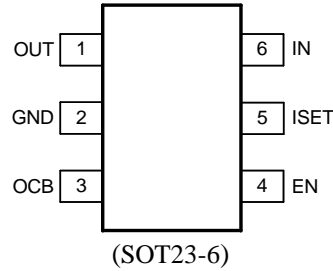

Figure2. RSET vs. Current Limit

Pinout (top view)



Top Mark: **dExyz** for SY6863B3ABC (Device code: dE; x=*year code*, y=*week code*, z=*lot number code*)

Pin Name	Pin number	Pin Description
OUT	1	Output pin.
GND	2	Ground pin.
OCB	3	Fault Flag. Open drain under normal conditions, grounded under fault operation.
EN	4	ON/OFF control. Active high. Do not leave it floating.
ISET	5	Current limit programming pin. Connect a resistor R_{SET} from this pin to ground to program the current limit: $I_{LIM} (A) = 7100/R_{SET} (\Omega)$
IN	6	Input pin.

Block Diagram

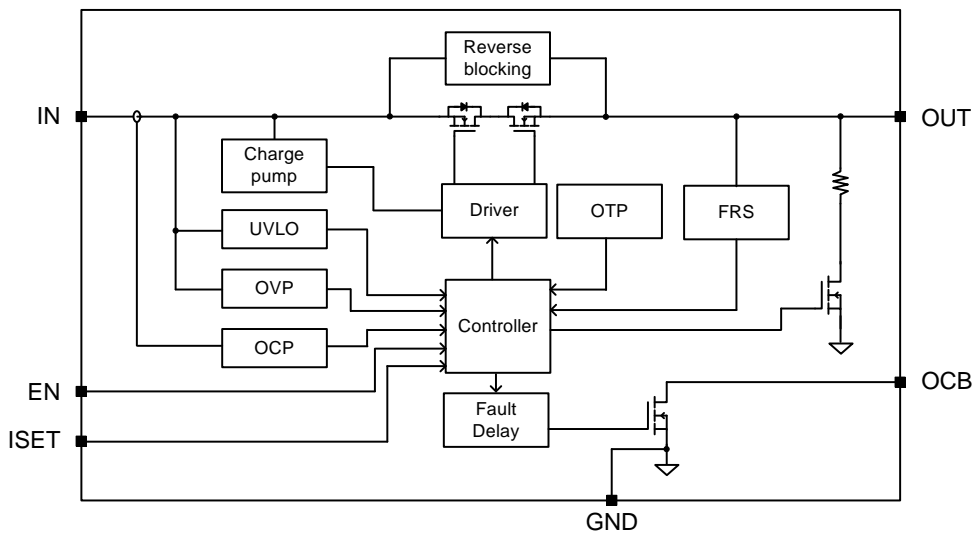

Figure3. Block Diagram



Absolute Maximum Ratings (Note 1)

IN-----	-0.3V to 7V
ISET -----	-0.3V to 3.6V
OCB, EN, OUT -----	-0.3V to 28V
Power Dissipation, P _D @ T _A = 25°C SOT23-6-----	1.2W
Package Thermal Resistance (Note 2)	
θ _{JA} -----	81°C/W
θ _{JC} -----	14°C/W
Junction Temperature Range-----	-40°C to 150°C
Lead Temperature (Soldering, 10 sec.) -----	260°C
Storage Temperature Range -----	-65°C to 150°C

Recommended Operating Conditions (Note 3)

IN-----	2.5V to 5.5V
ISET -----	0V to 3.3V
OCB, EN, OUT -----	0V to 22V
Junction Temperature Range -----	-40°C to 125°C
Ambient Temperature Range -----	-40°C to 85°C

Electrical Characteristics

($V_{IN} = 5V$, $C_{OUT} = 10\mu F$, $T_A = 25^\circ C$, unless otherwise specified)

Parameter	Symbol	Test Conditions	Min	Typ	Max	Unit
Input Voltage Range	V_{IN}		2.5		5.5	V
Output Over Voltage Protection	V_{OVP}			5.6		V
OVP Hysteresis	V_{OVP_HYS}			0.1		V
Shutdown Input Current	I_{SHDN}	Open load, switch OFF		5	30	μA
		Output grounded, switch OFF		5	30	μA
Quiescent Supply Current	I_Q	Open load, switch ON		150		μA
FET $R_{DS(ON)}$	$R_{DS(ON)}$	$V_{IN} = 5V$, $I_{OUT} = 2A$		45	50	m Ω
Current Limit	I_{LIM}	$R_{SET} = 1.878k$, $V_{IN} = 5V$, $V_{OUT} = 4.75V$	3.47	3.78	4.08	A
Programmable Current Limit Range	I_{LIM_RANGE}		0.4		4	A
EN Threshold	Logic-Low Voltage	V_{IL}			0.4	V
	Logic-High Voltage	V_{IH}	1.0			V
IN UVLO Threshold	$V_{IN,UVLO}$				2.45	V
IN UVLO Hysteresis	$V_{IN,HYS}$			0.1		V
Rise Time	t_{RISE}	$V_{IN} = 3.3V$, $R_L = 10\Omega$, $C_L = 1\mu F$	1.0	1.9	3.0	ms
		$V_{IN} = 5.0V$, $R_L = 10\Omega$, $C_L = 1\mu F$	1.5	3.0	4.5	ms
OCB Low Resistance	R_{OCB}			125		Ω
OCB Delay Time	t_{OCB_Delay}			15		ms
OUT Shutdown Discharge Resistance	R_{DSG}		90	115	140	Ω
Discharge Time	t_{DSG}			130		ms
Fast Role Swap Response	t_{FRS}	From V_{OUT} drops below 4.75V to V_{OUT} back to 4.75V		100		μs
Thermal Shutdown Temperature	T_{SD}			150		$^\circ C$
Thermal Shutdown Hysteresis	T_{HYS}			20		$^\circ C$

Note 1: Stresses beyond the “Absolute Maximum Ratings” may cause permanent damage to the device. These are stress ratings only. Functional operation of the device at these or any other conditions beyond those indicated in the operational sections of the specification is not implied. Exposure to absolute maximum rating conditions for extended periods may affect device reliability.

Note 2: θ_{JA} is measured in the natural convection at $T_A = 25^\circ C$ on a Silergy’s test board. Pin 2 of SOT23-6 package is the case position for θ_{JC} measurement.

Note 3: The device is not guaranteed to function outside its operating conditions.

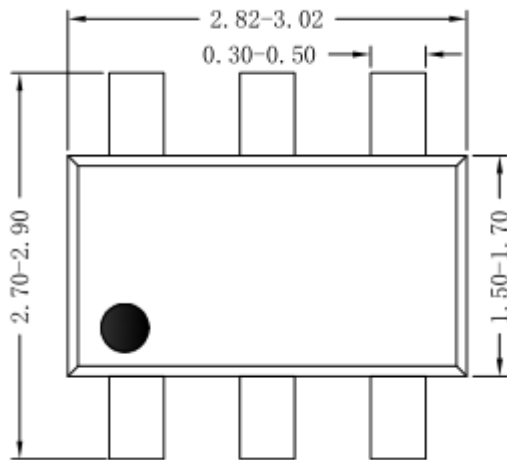
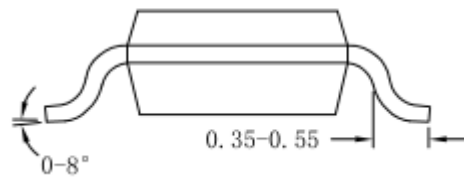
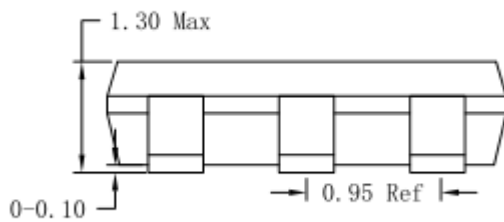
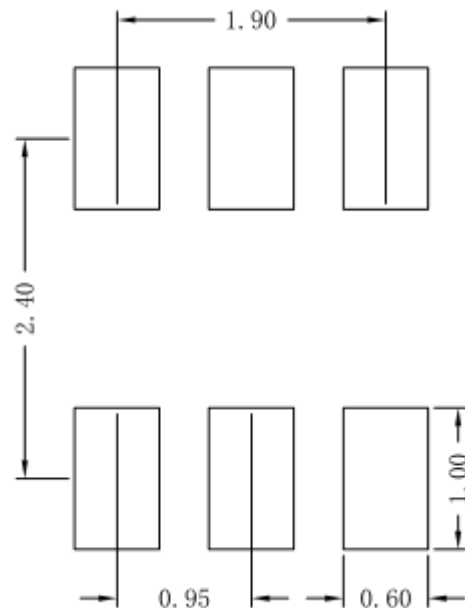
SOT23-6 Package Outline & PCB Layout

Top View

Side View

Side View

Recommended Pad Layout

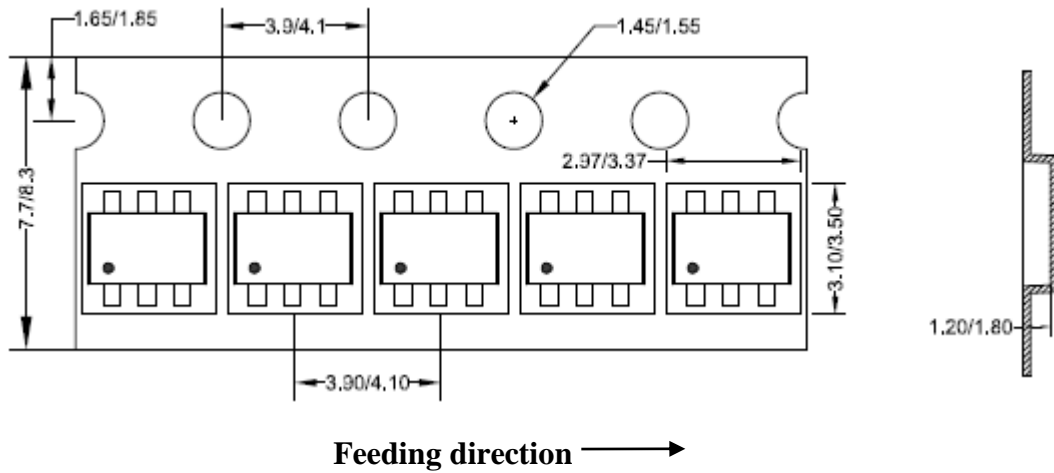
Notes: All dimension in millimeter and exclude mold flash & metal burr.

Taping & Reel Specification

1. Taping orientation

SOT23-6



2. Carrier Tape & Reel specification for packages

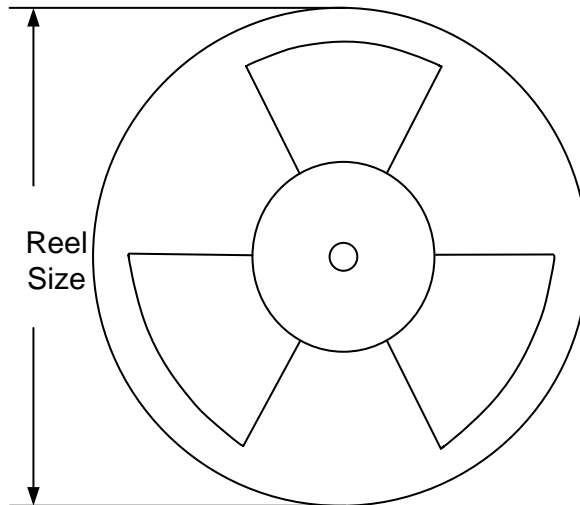

Package type	Tape width (mm)	Pocket pitch (mm)	Reel size (Inch)	Trailer length (mm)	Leader length (mm)	Qty per reel
SOT23-6	8	4	7"	280	160	3000

3. Others: NA

单击下面可查看定价，库存，交付和生命周期等信息

[>>SILERGY\(矽力杰\)](#)