

## USB Type-C PD and PWM Buck Controller with AnyPower<sup>™</sup> and PD Safe<sup>®</sup> Features

### General Description

The RTQ7881A-QT is a USB Type-C Power Delivery (USB-C PD) and PWM buck controller with highly integrated functions and the flexibility for USB PD provider applications. The IC has embedded an ARM Cortex<sup>™</sup>-M0 MCU so as to handle various functions of communication protocol, smart control of the PWM converter, firmware-based protections, and customized functions. The IC features hardware-based protections, such as inductor peak current limit, VBUS over-voltage protection (VBUS OVP), VO under-voltage protection (VO UVP), and VCONN current limit protection, so that the protections have faster responses and can still function properly even when the MCU is not activated. The RTQ7881A-QT hereby offers an excellent USB PD solution for a USB-PD Provider application with minimal external components and simple PCB layout.

### Ordering Information

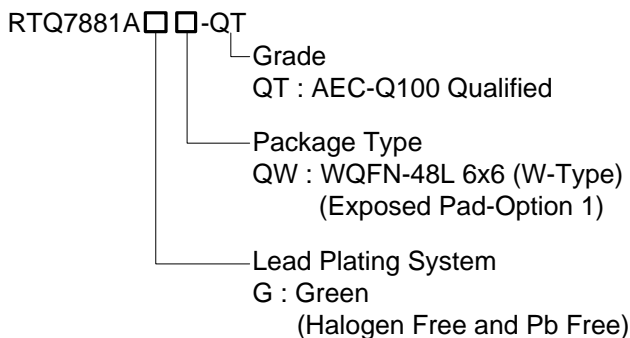

Note :

Richtek products are :

- ▶ RoHS compliant and compatible with the current requirements of IPC/JEDEC J-STD-020.
- ▶ Suitable for use in SnPb or Pb-free soldering processes.

### Features

- Support USB Type-C Power Delivery (PD) Provider Application
- AEC-Q100 Grade 2 Qualified
- Operating Ambient Temperature : -40°C to 105°C
- Type-C, USB PD and Communication Protocols
  - ▶ Compliant with USB PD 3.0 Specification, USB Type-C Cable and Connector Specification 1.2
  - ▶ Alternate Mode and VCONN Output
  - ▶ Support Other Proprietary Communication Protocols through Internal MCU, DP and DM Pins
- Integrated PWM Buck Controller
  - ▶ Wide Input Voltage Range : 4V to 36V
  - ▶ Peak-Current Mode PWM Operation
  - ▶ Programmable PWM Switching Frequency (200kHz to 600kHz)
  - ▶ Pulse-Skipping Mode for Light-Load Efficiency; Selectable Forced CCM Operation
- AnyPower<sup>™</sup> for Constant Voltage Output (11.7 or 23.4mV/step, typ.) and Constant Current (in 9-Bit Resolution) Output Settings
- PD Safe<sup>®</sup>
  - ▶ Adjustable Converter Input Current Limit
  - ▶ Programmable VBUS OVP and VO UVP
  - ▶ Adjustable External OTP
  - ▶ VCONN1/2 Output Current Limit
- Cable Voltage Drop Compensation for VBUS
- Master and Slave I<sup>2</sup>C Interfaces
- GPIOs for MUX Control or Customized Functions
- Built-in Output Bleeders for Quick VBUS Discharge
- Built-in Charge Pump for Driving Cost-Effective N-MOSFETs
- Available in WQFN-48L 6x6 Package
- Online Firmware Update via Slave I<sup>2</sup>C Interface

### Applications

- Automotive USB Type-C Power Delivery Charger

## Marking Information

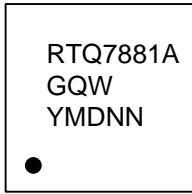

RTQ7881AGQW-QT : Product Number  
YMDNN : Date Code

## Pin Configuration

(TOP VIEW)

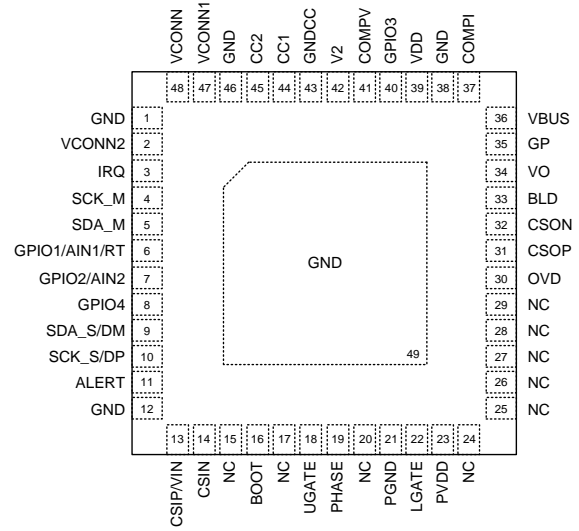

WQFN-48L 6x6

## Simplified Functional Block Diagram

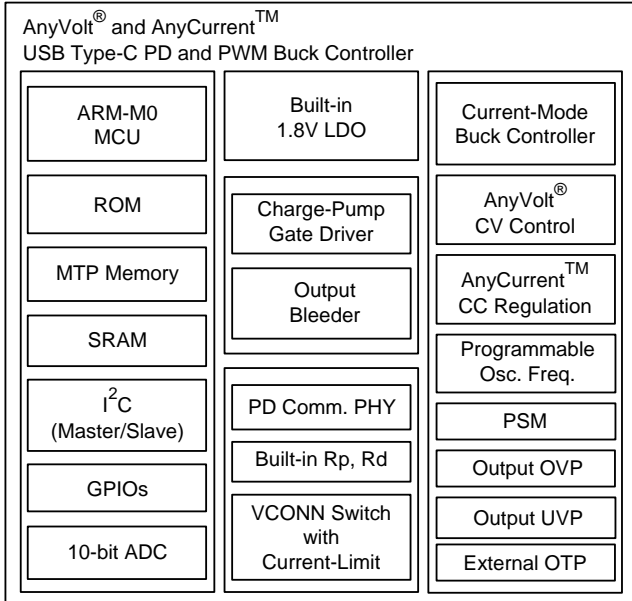

## Simplified Application Circuit

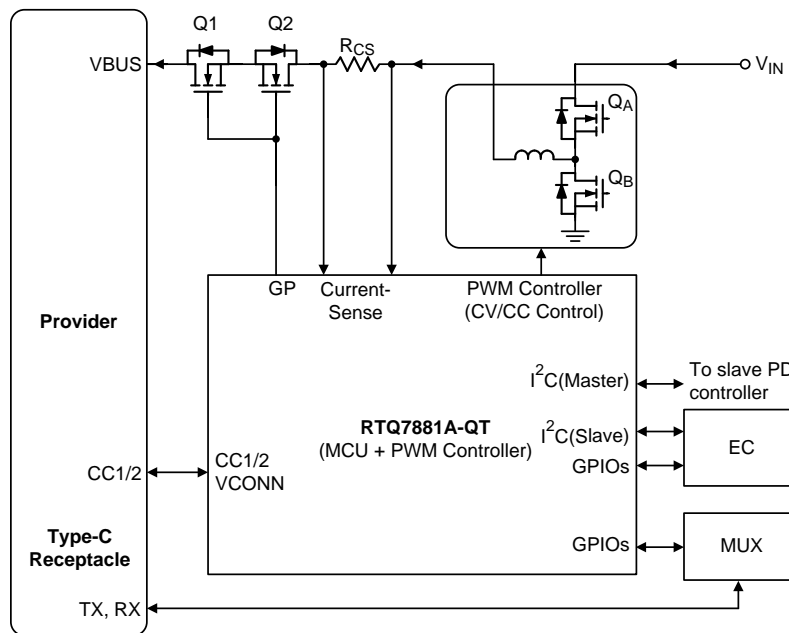

**Functional Pin Description**

Pin No.	Pin Name	Pin Function
1, 12, 38, 46	GND	Analog ground.
2	VCONN2	Power output to supply USB plug power (V <sub>CONN</sub> ) via USB Type-C CC2. A MOSFET is to turn on/off the power path from VCONN to VCONN2. This pin is connected to USB Type-C CC2 via a Schottky diode.
3	IRQ	Interrupt input. The RTQ7881A-QT will do emergency control when it receives a low-level signal via this pin. This pin can be set as an open-drain or push-pull GPIO pin.
4	SCK_M	Open-drain clock signal output from the master I <sup>2</sup> C interface. This pin can be set as an open-drain or push-pull GPIO pin.
5	SDA_M	Open-drain data signal input / output for the master I <sup>2</sup> C interface. This pin can be set as an open-drain or push-pull GPIO pin.
6	GPIO1/AIN1/RT	Open-drain/push-pull GPIO, analog input or input for external over-temperature protection (EOTP). An NTC is connected from this pin to GND for the EOTP.
7	GPIO2/AIN2	Open-drain/push-pull GPIO or analog input. Connect this pin to GND if it is not used.
8	GPIO4	Open-drain/push-pull GPIO.
9	SDA_S/DM	Open-drain data signal input / output for the slave I <sup>2</sup> C interface or USB D-data line input / output. This pin can be set as an open-drain GPIO or connected to USB D- terminal for special communication protocol.
10	SCK_S/DP	Clock signal input for the slave I <sup>2</sup> C or USB D+ data line. It is set as an open-drain GPIO or connected to USB D+ for special communication protocol.
11	ALERT	Open-drain Interrupt signal output. An external MCU can check the slave I <sup>2</sup> C registers to do emergency control when it receives a low-level signal from this pin. This pin can be set as an open-drain or push-pull GPIO.
13	CSIP/VIN	Positive input for input current sensing or voltage-sense input for input voltage of the converter.
14	CSIN	Negative input for input current sensing.
15, 17, 20, 24, 25, 26, 27, 28, 29	NC	No internal connection.
16	BOOT	Bootstrap capacitor connection node. Connect a 0.1μF ceramic capacitor from this pin and the PHASE pin to power the internal high-side gate driver.
18	UGATE	High-side gate driver output.
19	PHASE	Negative power-rail pin of the high-side gate driver.
21	PGND	Ground of the low-side gate drivers and one input pin of zero-current detection at the MOSFET controlled by LGATE. Connect this pin to the source of the MOSFET.
22	LGATE	Low-side gate driver output.
23	PVDD	Bias voltage (5V typ.) supply for the low-side gate drivers. It is recommended to connect an external MLCC (1μF) from this pin to PGND pin.
30	OVD	Output over-voltage protection input pin.

Pin No.	Pin Name	Pin Function
31	CSOP	Positive input of an offset-cancelled current-sense amplifier to sense the output current for constant current regulation and also through an ADC to the MCU. Connect this pin to the positive terminal of output current-sense resistor via an RC filter.
32	CSON	Negative input of an offset-cancelled current-sense amplifier for output constant-current regulation and output current detection. Connect this pin to the negative terminal of output current-sense resistor via an RC filter.
33	BLD	Bleeder connection node. An output bleeder, comprising a pull-low NMOS, is built in to provide another path to discharge the output capacitor of the PWM converter. Connect this pin to the converter output through an external resistor.
34	VO	Input of feedback voltage from converter output. The voltage is monitored for output under-voltage protection.
35	GP	Charge-pump gate driver output. It drives N-channel power MOSFET(s) to turn on / off the output power path.
36	VBUS	USB-C VBUS voltage input. The voltage at this pin is monitored for USB-C VBUS over-voltage protection with an 8-bit programmable threshold voltage.
37	COMPI	Constant-current (CC) loop error amplifier output. Connect an external RC circuit between this pin and GND for the CC loop feedback compensation.
39	VDD	IC bias voltage (5V typ.) input. It is recommended to connect this pin to a 5V system voltage via an RC filter of 1 $\mu$ F and 4.7 $\Omega$ .
40	GPIO3	Open-drain / push-pull GPIO.
41	COMPV	Constant-voltage (CV) loop error amplifier output. Connect an external RC network between this pin and GND for constant-voltage (CV) loop feedback compensation.
42	V2	Internal 1.8V linear regulator output to supply power for internal circuitry. An MLCC (1 $\mu$ F typ. or greater) must be connected from this pin to ground.
43	GNDCC	Ground for Configuration Channel (CC) circuitry.
44	CC1	Type-C connector Configuration Channel (CC) 1. Generally, this input/output pin is connected to USB Type-C connector CC1 terminal.
45	CC2	Type-C connector Configuration Channel (CC) 2. Generally, this input/output pin is connected to USB Type-C connector CC2 terminal.
47	VCONN1	Power output to supply USB plug power (VCONN) through USB Type-C CC1 terminal. A MOSFET is built in to turn on/off the power path, from VCONN to VCONN1. This pin is connected to CC1 terminal via a Schottky diode.
48	VCONN	Power input for sourcing VCONN via the power path to VCONN1 or VCONN2. This pin is connected to a regulated 5V voltage source.
49 (Exposed Pad)	GND	Ground. The exposed pad must be soldered to a large PCB and connected to GND for maximum power dissipation.

**Functional Block Diagram**

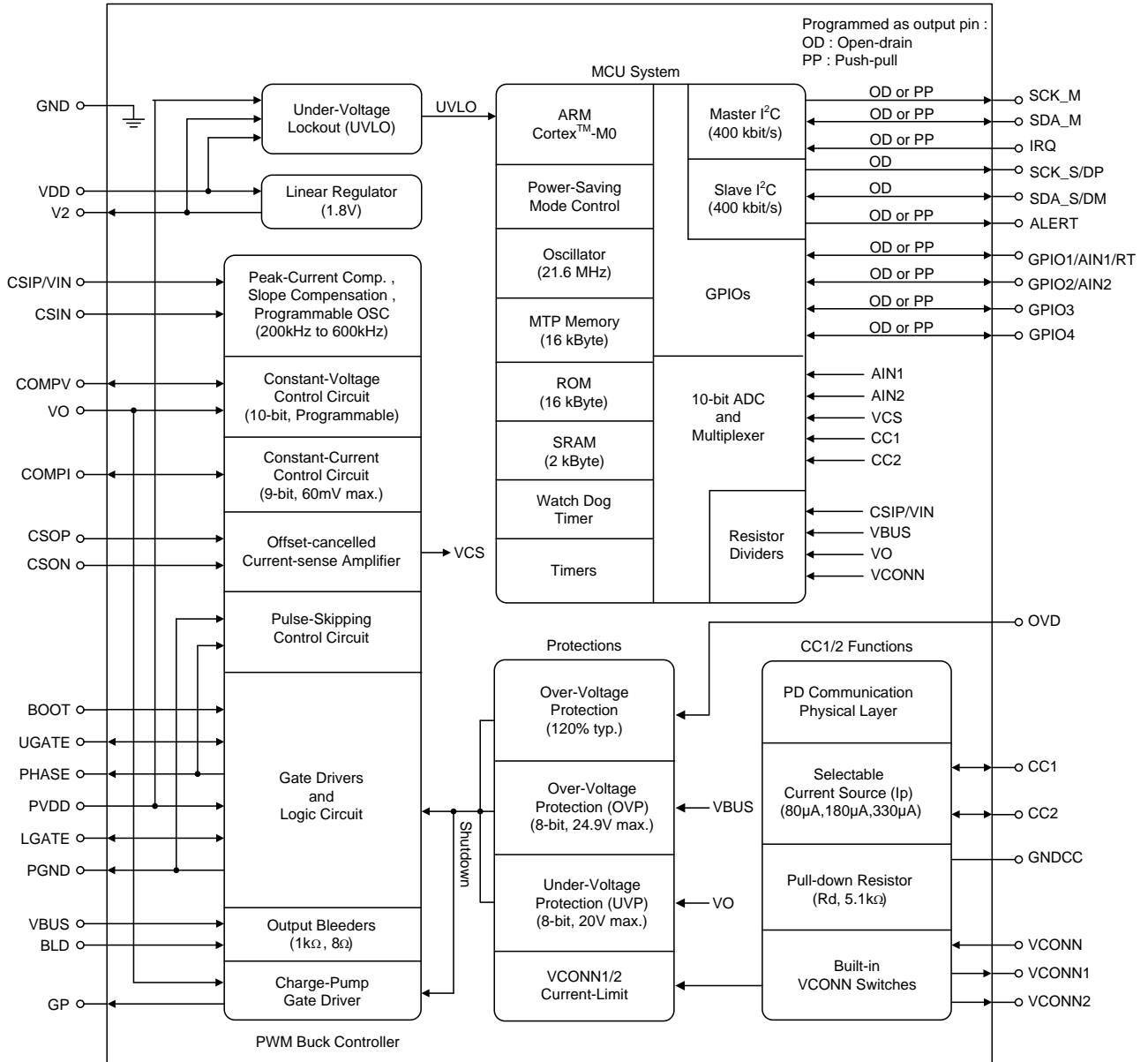

## Operation

The RTQ7881A-QT is a versatile USB Type-C Power Delivery (USB-C PD) and PWM Buck controller designed especially for applications as Providers. It's a highly integrated solution, comprising four main functional blocks: MCU System, PWM Buck Controller, Protections and CC1/2 Functions as depicted in the "Functional Block Diagram".

The MCU System embeds an ARM Cortex™-M0 MCU, a multi-time programming (MTP) memory, a ROM, an SRAM, a 10-bit ADC (analog to digital converter), two I<sup>2</sup>C interfaces (slave and master) and GPIO (general purpose input or output) pins. The MCU System is programmed to perform power controls, customized functions, as a policy engine and a device policy manager. This MCU reports the operating status of PD operation, such as present input/output voltage, output current and external temperature to an EC (embedded controller) or AP (application processor) and receives commands from the EC/AP, as a system policy manager, via the slave I<sup>2</sup>C interface. The GPIO pins can be used to control high-speed multiplexers or other customized functions.

The "PWM Buck controller" consists of an AnyVolt® constant-voltage (CV) control circuit (11.7 or 23.4mV/step, typ.), an AnyCurrent™ constant-current (CC) control circuit, an offset-cancelled output current-sense amplifier (23.5mA to 47mA/step, depending on the current-sense resistor), built-in gate drivers, one charge-pump gate driver and output bleeders (at BLD and VBUS pins). Generally, either the CV or the CC control circuit regulates the output voltage or current through peak-current mode PWM operation. Diode emulation function and pulse-skipping mode (PSM) are built in to improve power efficiency at light loads. The output current-sense amplifier (OCS-AMP) allows current-sense resistors as low as 5mΩ to 15mΩ for reducing power loss. Moreover the charge-pump driver adopts N-channel MOSFETs for on/off control of output power-path, instead of P-channel MOSFETs having higher cost. In operation the output bleeders at BLD and VBUS pins can be turned on to discharge output voltage (VBUS) during the VBUS negative transition, in the hard reset process, or after the removal of the USB-C connector.

The PD Safe® power delivery operation consists of over-voltage protection (OVP) at the VBUS pin, under-voltage protection at the VO pin, output CC regulation and VCONN1/2 output current-limit function. With the PD Safe® feature, trip levels of the OVP and UVP can be set dynamically for each output voltage target. The CC regulation level is also adaptively programmed according to the current level in full load.

The "CC1/2 Functions" block consists of the physical layer, three selectable levels of the pull-up current sources Ip (instead of resistors Rp), a controllable pull-down resistor Rd and programmable VCONN power-path switches.

### Under-Voltage Lockout (UVLO)

The RTQ7881A-QT UVLO function continuously monitors bias voltages at the VDD and V2 pins. When both of the supply voltages (VDD and V2) rise above the respective rising UVLO thresholds, the internal UVLO signals will go low to activate the MCU. In addition, the IC also monitors the bias voltage at the PVDD pin for UVLO function. Only when all of the UVLO signals go low, or the PWM Buck controller will not be activated; meanwhile the MCU or PWM controllers will be kept in the "Under-Voltage Lockout" state to prevent any undesirable operation.

### Pulse-Skipping Mode (PSM) with Diode Emulation

When a switch-mode converter operates in light load condition, most power loss is caused by switching losses. To reduce switching loss in light load condition, the switching frequency needs to be reduced by entering the pulse-skipping mode (PSM) and the discontinuous conduction mode (DCM). In this operation, an internal compensation voltage VCOMP is compared by a PSM comparator, which has a programmable PSM threshold.

When the compensation voltage VCOMP (which follows the voltage at COMPV, or COMPI pin) is above the PSM threshold, the converter works in normal fixed-frequency PWM mode. As long as the VCOMP drops below the PSM threshold, the converter will enter the pulse-skipping mode to reduce switching frequency and thus diminish switching losses. The PSM

threshold also defines the minimum inductor peak current in PSM operation. Setting a larger PSM threshold will give a higher minimum peak current which in turn gives a lower switching frequency at light load for better light load efficiency at the cost of increased output voltage ripple. Conversely, a lower PSM threshold gives lower peak current and lower PSM ripple at the cost of worse light load efficiency.

A Diode Emulation Mode (DEM) is also a necessary function to avoid delivering energy from converter output to converter input during dynamic output voltage control. The DEM function is equipped with a zero-current detection (ZCD) circuits. The Source-to-Drain voltage ( $V_{SD}$ , detected via PGND and PHASE pins) of the low-side MOSFET is compared with a zero-current threshold ( $V_{TH\_ZCD}$ ). When the  $V_{SD}$  drops below the  $V_{TH\_ZCD}$  voltage, the RTQ7881A-QT turns off the low-side MOSFET thereby avoiding reverse inductor current. In DEM operation, the behavior of the low-side MOSFET resembles a diode.

**Cable Voltage Drop Compensation (CDC)**

In a power delivery system with both a Provider and a Consumer, the Provider with the RTQ7881A-QT AnyVolt® feature can slightly adjust its CV output voltage to compensate voltage drop across the USB cable. A PD controller of the Consumer can request higher VBUS voltage from the Provider through PD communication to achieve an accurate application voltage.

There is another method to implement the CDC function without PD communication. The RTQ7881A-QT can use the ADC to detect the output current-sense voltage ( $V_{CSO}$ ) between CSOP and CSON pins and adaptively add a proper output voltage offset ( $V_{CDC}$ ) to compensate the cable voltage drop. The output voltage offset ( $V_{CDC}$ ) is gradually added by adjusting the CV regulated output voltage ( $V_{REG\_VO}$ ) and is approximately proportional to the converter output current ( $I_{OUT}$ ).  $V_{CDC}$  is approximately determined by the following equation :

$$V_{CDC} = I_{OUT} \times R_{CABLE}$$

where :

$R_{CABLE}$  is a preset value of parasitic resistance of USB cable.

**VBUS Over-Voltage Protection (VBUS OVP)**

In Figure 1, the VBUS OVP function is a hardware-based protection which monitors the voltage at the VBUS pin via a built-in resistor-divider. When the VBUS voltage exceeds its OVP threshold, the output of the OVP comparator goes high and starts the debounce time counting. At the end of the debounce time counting, the signal VBUS OVP goes high to turn off the PWM controller. The OVP trip voltage is programmable from 3V to 24.9V (8-bit, 97.66mV/step typ.) and its debounce time is also selectable to meet various application requirements.

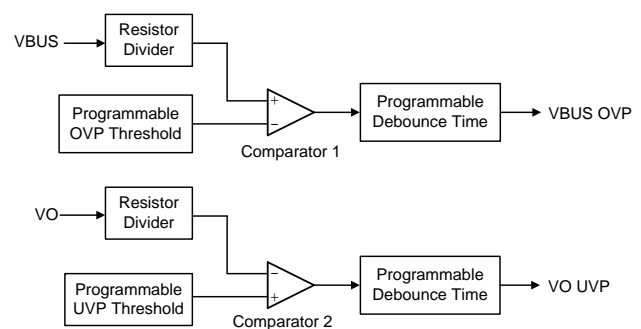

Figure 1. Functional diagram of VBUS OVP and VO UVP

**VO Under-Voltage Protection (VO UVP)**

In Figure 1, the VO UVP function is a hardware-based protection which monitors the voltage at the VO pin via a built-in resistor-divider. When the VO voltage falls below its UVP threshold, the output of the UVP comparator goes high and starts the debounce time counting. At end of the debounce time, the signal VO UVP goes high to turn off PWM controller. The UVP trip voltage is programmable from 3V to 20V (8-bit, 93.75mV/step typ.) and its debounce time is also selectable to avoid false triggering and to meet various application requirements.

## AnyCurrent™ Constant-Current (CC) Regulation

It is noted that a robust system is very important in USB PD operations, the AnyCurrent™ CC regulation allows setting the most suitable CC level for a negotiated PD system.

The RTQ7881A-QT integrates a current-sense amplifier to sense output current for CC regulation and also through an ADC to the MCU for the output current to be recorded.

The amplifier is embedded with offset cancellation function to accurately sense the current-sense voltage (i.e.,  $VCS = \text{output current} \times \text{current-sense resistor}$ ) between the CSOP and CSON pins. The recommended current-sense voltage range for CC regulation is from 10mV to 60mV which is programmed by an internal 9-bit DAC (digital-to analog converter) with 0.1174mV/step resolution.

## Power-Path Gate Driver for Driving N-Channel MOSFETs

The RTQ7881A-QT integrates a power-path gate driver to control external output blocking MOSFETs between the output of the PWM converter and the USB-C VBUS terminal. A built-in charge pump is included to supply the gate driver to turn on the external N-channel power MOSFETs, which allow power systems to be more

cost-effective, compared to the counterpart, P-channel power MOSFETs.

## Power Output for USB Plug Power (VCONN)

In Figure 2, either one of the VCONN1 and VCONN2 pins is selected to power an external electrically marked (E-mark) or active cable. Two internal MOSFETs, between VCONN to VCONN1 and VCONN2 pins, are used to control the VCONN power path to VCONN1 or to VCONN2. It is recommended to connect the VCONN1/2 pins to USB-C CC1/2 terminals via Schottky diodes (D1/2) to prevent reverse current. The input pin VCONN must be connected to an external 5V power source.

## Online Firmware Update via Slave I<sup>2</sup>C Interface

The embedded MTP memory allows the RTQ7881A-QT's firmware to be updated by an EC (Embedded Controller) or AP (Application Processor) through the I<sup>2</sup>C slave interface. The RTQ7881A-QT provides some firmware-programmable design features, which greatly eases the design efforts during product development stage. End users are also allowed to update the firmware through internet to make software changes based on their needs.

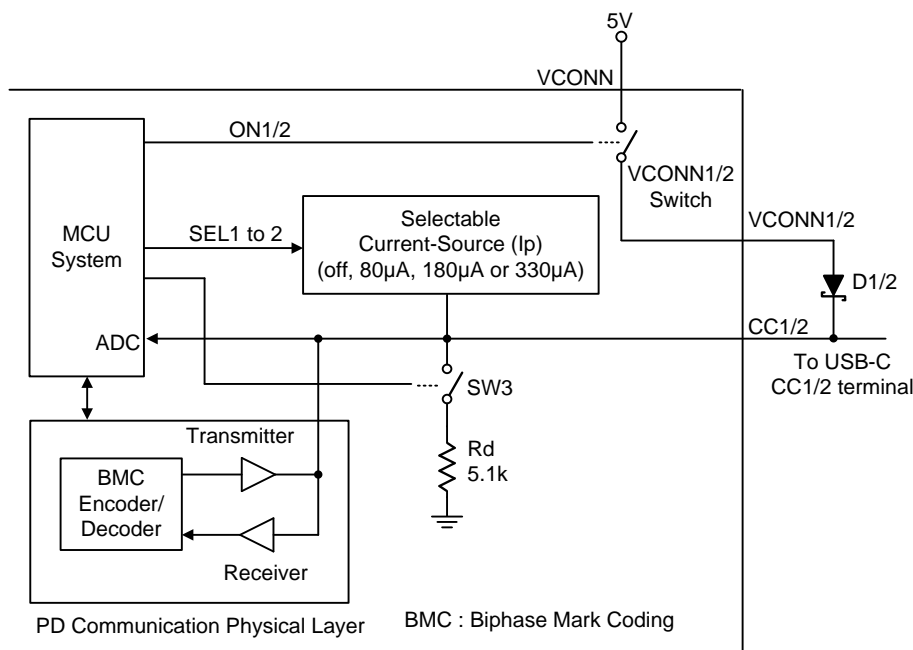

Figure 2. Functional diagram of VCONN and CC1/2 functions



**Absolute Maximum Ratings** (Note 1)

- V2 to GND----- -0.3V to 2.5V
- VDD, PVDD, VCONN to GND----- -0.3V to 6.5V
- COMPV, COMPI to GND----- -0.3V to 6.5V
- VCONN1, VCONN2 to GND----- -0.3V to  $V_{VCONN} + 0.3V$
- VBUS, CSOP, CSON, VO, BLD, OVD to GND ----- -0.3V to 25V
- CSOP to CSON Voltage----- -5V to 5V
- GP to GND----- -0.3V to 33V
- CSIP/VIN, CSIN to GND----- -0.3V to 40V
- CSIP/VIN to CSIN Voltage ----- -5V to 5V
- I<sup>2</sup>C Pins (SCK\_S/DP, SDA\_S/DM, ALERT, SCK\_M, SDA\_M, IRQ) to GND----- -0.3V to 6.5V
- GPIO Pins (GPIO1/AIN1/RT, GPIO2/AIN2, GPIO3, GPIO4) to GND ----- -0.3V to 6.5V
- CC1, CC2 to GND----- -0.3V to 25V
- BOOT to PHASE ( $V_{BOOT-PHASE}$ )----- -0.3V to 6.5V
- UGATE to PHASE ----- -0.3V to  $V_{BOOT-PHASE} + 0.3V$
- PHASE to GND (DC)----- -5V to 40V
- <20ns ----- -5V to 45V
- LGATE to PGND ----- -0.3V to  $V_{PVDD} + 0.3V$
- PGND, GNDCC to GND----- -0.3V to 0.3V
- Power Dissipation,  $P_D$  @  $T_A = 25^\circ C$
- WQFN-48L 6x6 ----- 3.73W
- Package Thermal Resistance (Note 2)
- WQFN-48L 6x6,  $\theta_{JA}$  ----- 26.8°C/W
- WQFN-48L 6x6,  $\theta_{JC}$  ----- 1.3°C/W
- Lead Temperature (Soldering, 10 sec.)----- 260°C
- Junction Temperature----- 150°C
- Storage Temperature Range----- -65°C to 150°C
- ESD Susceptibility (Note 3)
- HBM (Human Body Model) ----- 2kV

**Recommended Operating Conditions** (Note 4)

- PWM Converter Input Voltage,  $V_{IN}$  ----- 4V to 36V
- PWM Converter Output Voltage,  $V_{OUT}$  ----- 3V to 22V
- VDD Supply Voltage----- 4.25V to 5.5V
- PVDD Supply Voltage----- 4.5V to 5.5V
- Junction Temperature Range ----- -40°C to 125°C
- Ambient Temperature Range----- -40°C to 105°C
- Minimum MTP Memory Write/Erase Cycles ----- 100cycles

## Electrical Characteristics

(V<sub>DD</sub> = V<sub>PVDD</sub> = V<sub>VCONN</sub> = 5V, T<sub>J</sub> = -40°C to 105°C, unless otherwise specified)

Parameter	Symbol	Test Conditions	Min	Typ	Max	Unit
<b>Operating Currents and V2 Linear Regulator</b>						
VDD Normal Operating Current	I <sub>OP_VDD</sub>	PWM = MCU = on, digital output pins = open	--	10	15	mA
VDD Operating Current in Green-Mode (GM)	I <sub>GM_VDD</sub>	PWM = on, MCU = off, GP = on, digital output pins = open	--	5	8	mA
VDD Operating Current in Deep Green-Mode (DGM)	I <sub>DGM_VDD</sub>	PWM = MCU = off, digital output pins = open	--	75	450	μA
V2 Output Voltage	V <sub>REGV2</sub>	I <sub>V2</sub> = 0A	1.58	1.76	1.94	V
V2 Short-Circuit Current			30	50	80	mA
PVDD Input Current in PWM Shutdown			--	--	3	μA
VCONN Input Current		Resistor-divider and switches are off	--	--	3	μA
BOOT Input Current in PWM Shutdown		V <sub>BOOT</sub> = 4.5V	--	--	3	μA
<b>Under-Voltage Lockout (UVLO), Over/Under-Voltage Protection (OVP/UVP) and Max. On-Time Protection</b>						
VDD UVLO Voltage Threshold		V <sub>DD</sub> rising	3.8	4	4.2	V
VDD UVLO Voltage Hysteresis			--	0.25	--	V
V2 UVLO Voltage Threshold		V <sub>V2</sub> rising	--	1.4	--	V
V2 UVLO Voltage Hysteresis			--	0.2	--	V
PVDD UVLO Threshold		V <sub>PVDD</sub> rising	3.8	4	4.2	V
PVDD UVLO Hysteresis			--	0.2	--	V
CSIP/VIN UVP Threshold		Enabled by firmware, V <sub>CSIP/VIN</sub> rising	2.7	2.9	3.1	V
CSIP/VIN UVP Hysteresis			--	0.25	--	V
VBUS OVP Voltage Threshold Range	V <sub>TH_VBUSOV</sub>	Programmable(8-bit), 97.66mV/step at V <sub>VBUS</sub> pin	3.03	--	24.9	V
VBUS OVP Voltage Threshold Accuracy		Setting of V <sub>TH_VBUSOV</sub> = 5.96V/24V, V <sub>VBUS</sub> rising	-5	--	5	%
VBUS OVP Debounce Time	t <sub>DB_VBUSOV</sub>	Programmable, V <sub>VBUS</sub> rising	--	4.5 7 12 22	6.6 9.6 15.6 27.6	μs
VO UVP Voltage Threshold Range	V <sub>TH_VOUV</sub>	Programmable (8-bit), 93.75mV/step (typ.)	3	--	19.97	V
VO UVP Voltage Threshold Accuracy		Nominal V <sub>TH_VOUV</sub> = 3V/15V, V <sub>VO</sub> falling	-5	--	5	%
VO UVP Debounce Time		V <sub>VO</sub> falling, programmable	--	8 10.5 15.5 25.5	13.6 16.6 22.6 34.6	μs

Copyright © 2021 Richtek Technology Corporation. All rights reserved. RICHTEK is a registered trademark of Richtek Technology Corporation.

www.richtek.com

DSQ7881A-QT-00 July 2021

Parameter	Symbol	Test Conditions	Min	Typ	Max	Unit
VO UVP Blanking Time during Start-Up		Programmable	4 8 16 32	5 10 20 40	6 12 24 48	ms
<b>CC1/2 Voltage Detections, BMC Transmitter/Receiver and VCONN Switches</b>						
CC1/2 Voltage Detection Range		Using the 10-bit ADC	0	--	2.7	V
CC1/2 Voltage Detection Accuracy		Using the 10-bit ADC, V <sub>CC1/2</sub> = 0.1 to 2.7V	-40	--	40	mV
CC1/2 Pull-Up Current Source – 1	Ip1	For default USB power	64	80	96	μA
CC1/2 Pull-Up Current Source – 2	Ip2	For 1.5A and 5V	165.6	180	194.4	μA
CC1/2 Pull-Up Current Source – 3	Ip3	For 3A and 5V	303.6	330	356.4	μA
CC1/2 Pull-Down Resistor	Rd	Reserved	4.6	5.1	5.6	kΩ
CC1/2 Maximum Output Voltage		CC1/2 = open	--	V <sub>DD</sub> - 0.7V	--	V
Transmitter High-Level Output Voltage Range			1.05	--	1.2	V
Transmitter Low-Level Output Voltage Range			0	--	75	mV
Receiver High-Level Input Voltage Range			0.67	--	1.45	V
Receiver Low-Level Input Voltage Range			-0.25	--	0.43	V
Rising Time of the Transmitter Output Voltage		From 10% to 90%, C <sub>L</sub> = 200pF to 600pF	300	--	--	ns
Falling Time of the Transmitter Output Voltage		From 90% to 10%, C <sub>L</sub> = 200pF to 600pF	300	--	--	ns
On-Resistance of VCONN-to-VCONN1/2 MOSFET			--	0.4	0.8	Ω
VCONN1/2 Output Voltage Accuracy		Output current = 0 to 200mA	4.7	--	--	V
VCONN1/2 Current-Limit Threshold		VCONN1/2 = GND	350	500	650	mA
<b>MCU Section</b>						
MCU Clock Frequency	f <sub>MCU</sub>		19.4	21.6	23.8	MHz
MCU Clock Frequency in Deep Green-Mode	f <sub>MCU_DGM</sub>		--	80	--	kHz
<b>Charge-Pump Gate Driver (GP), I<sup>2</sup>C Pins (SCK_S, SDA_S, ALERT, SCK_M, SDA_M, IRQ) and GPIO Pins (GPIO1/2/3/4)</b>						
GP Pull-Low MOSFET On-Resistance			--	100	--	Ω

Parameter	Symbol	Test Conditions	Min	Typ	Max	Unit
Maximum GP Voltage		$V_{VO} = 20V$ , $R_{GP-to-GND} = 50M\Omega$	$V_{VO} + V_{DD}$	$V_{VO} + 2 \times V_{DD} - 3V$	$V_{VO} + 2 \times V_{DD} - 1V$	V
I <sup>2</sup> C/GPIO High-Level Input Voltage Range	$V_{IH}$	For the pins configured as input pins	1.5	--	--	V
I <sup>2</sup> C/GPIO Low-Level Input Voltage Range	$V_{IL}$	For the pins configured as input pins	--	--	0.4	V
I <sup>2</sup> C/GPIO High-Level Output Voltage	$V_{OH}$	Sourcing current = 2mA, for the pins configured as push-pull output pins	--	$V_{DD} - 0.8V$	--	V
I <sup>2</sup> C/GPIO Low-Level Output Voltage	$V_{OL}$	Sinking current = 2mA	--	--	0.3	V
I <sup>2</sup> C/GPIO Leakage Current		Pin input voltage = 5V	--	--	1	$\mu A$
Internal DP-to-DM On-Resistance	$R_{ON\_DPDM}$		--	12	30	$\Omega$
RT Current Source		$V_{RT} < 2.7V$	92	100	108	$\mu A$
<b>PWM Controller – Programmable Oscillator</b>						
Oscillator Frequency Range	$f_{OSC}$	Programmable	200	--	600	kHz
Oscillator Frequency Accuracy			-10	--	10	%
Maximum On-Time Range	$t_{ON\_MAX}$	Programmable	0.32	--	5.88	$\mu s$
<b>PWM Controller – Constant-Voltage (CV) Control Loop</b>						
CV Regulated Voltage Range at VO	$V_{REG\_VO}$	Programmable (10-bit), 11.719 or 23.438mV/step	3	--	11.99 23.98	V
Output Voltage Accuracy (at VO Pin)		$V_{OUT} = 5V/9V/12V/15V/20V$ , 23.438mV/step $V_{OUT} = 5V/9V$ , 11.719mV/step	-3	--	3	%
Trans-Conductance of COMPV Amplifier	$G_{mv}$	$I_{COMPV} = \pm 20\mu A$	330	550	770	$\mu A/V$
COMPV Maximum Output Voltage		COMPV = open	3.2	3.5	--	V
<b>PWM Controller – Constant-Current (CC) Control Loop and Output Current-Sense Amplifier (OCS-AMP)</b>						
CSON and CSOP Operating Voltage Range			3	--	22	V
CC Regulated Voltage Range between CSOP and CSON Pins	$V_{REF\_CC}$	Programmable (9-bit), 0.1174mV/step (typ.), $V_{CSON}$ and $V_{CSOP} > 3V$	10	--	60	mV
CC Reference Voltage Accuracy		Nominal $V_{REF\_CC} = 20mV/60mV$	-3	--	3	mV
Trans-conductance of COMPI Amplifier	$G_{mi}$	$I_{COMPI} = \pm 20\mu A$	330	550	770	$\mu A/V$
COMPI Maximum Output Voltage		COMPI = open	3.2	3.5	--	V

Parameter	Symbol	Test Conditions	Min	Typ	Max	Unit
<b>PWM Controller – Input Current Comparison and Slope Compensation</b>						
Maximum Input Current-Sense Voltage Threshold Range	V <sub>TH_CS</sub> MAX	Programmable	--	--	140	mV
Maximum Input Current-Sense Voltage Threshold Accuracy		V <sub>TH_CS</sub> MAX = 50mV, 100mV, 140mV	-15	--	15	mV
Leading Edge Blanking (LEB) Time of Input Peak/Over-Current Comparator	t <sub>LEBA</sub>	From V <sub>UGATE</sub> rising edge, programmable	--	100 150 200 250	--	ns
Voltage Rate Range of Slope Compensation		Programmable	0	--	92	mV/μs
<b>PWM Controller – Pulse-Skipping Mode (PSM) Operation with Zero-Current Detection (ZCD)</b>						
PSM Voltage Threshold Range at COMPV or COMPI Pin	V <sub>TH_PSM</sub>	Programmable	--	--	1.969	+V <sub>OFS</sub> 1/2
ZCD Voltage Threshold between PGND and PHASE Pins	V <sub>TH_ZCD</sub>	To compare the PGND-to-PHASE voltage	--	4	--	mV
ZCD LEB Time	t <sub>LEBB</sub>	Programmable, from V <sub>LGATE</sub> rising edge	--	100 150 200 250	--	ns
<b>PWM Controller – Gate Drivers</b>						
UGATE Pull-High Resistance		V <sub>BOOT-PHASE</sub> = 5V, V <sub>BOOT-UGATE</sub> = 0.1V	--	1.7	--	Ω
UGATE Pull-Low Resistance		V <sub>UGATE-PHASE</sub> = 0.1V	--	0.8	--	Ω
LGATE Pull-High Resistance		V <sub>PVDD</sub> - V <sub>LGATE</sub> = 0.1V	--	1.7	--	Ω
LGATE Pull-Low Resistance		V <sub>LGATE</sub> = 0.1V	--	0.8	--	Ω
Dead-Time before UGATE Rising Edge			--	20	--	ns
Dead-Time after UGATE Falling Edge			--	20	--	ns
<b>PWM Controller – Output Bleeders</b>						
On-Resistance of BLD Pull-Low MOSFET		Pull-low NMOS is on, sinking I <sub>BLD</sub> = 10mA	--	8	16	Ω
BLD Leakage Current		V <sub>BLD</sub> = 20V, pull-low NMOS is off	--	--	1	μA
V <sub>BUS</sub> Pull-Low Resistor		Pull-low NMOS is on	--	1.1	1.5	kΩ

- Note 1.** Stresses beyond those listed under “Absolute Maximum Ratings” may cause permanent damage to the device. These are stress ratings only, and functional operation of the device at these or any other conditions beyond those indicated in the operational sections of the specifications is not implied. Exposure to absolute maximum rating conditions may affect device reliability.
- Note 2.**  $\theta_{JA}$  is measured under natural convection (still air) at  $T_A = 25^\circ\text{C}$  with the component mounted on a high effective-thermal-conductivity four-layer test board on a JEDEC 51-7 thermal measurement standard.  $\theta_{JC}$  is measured at the exposed pad of the package.
- Note 3.** Devices are ESD sensitive. Handling precaution is recommended.
- Note 4.** The device is not guaranteed to function outside its operating conditions.

**Typical Application Circuit**

**Provider Circuit with Buck Converter for USB Car Charger Applications**

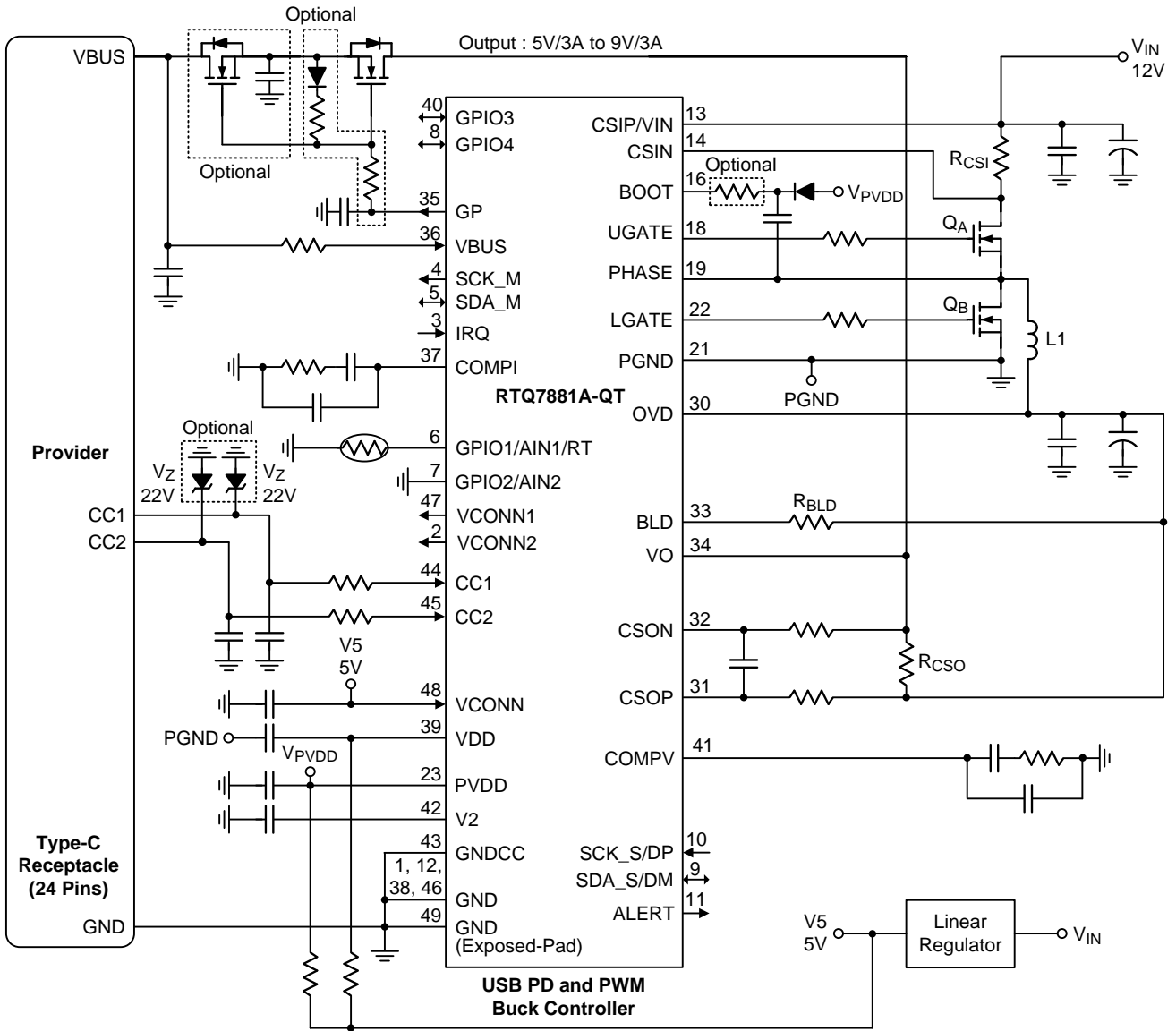

## Typical Operating Characteristics

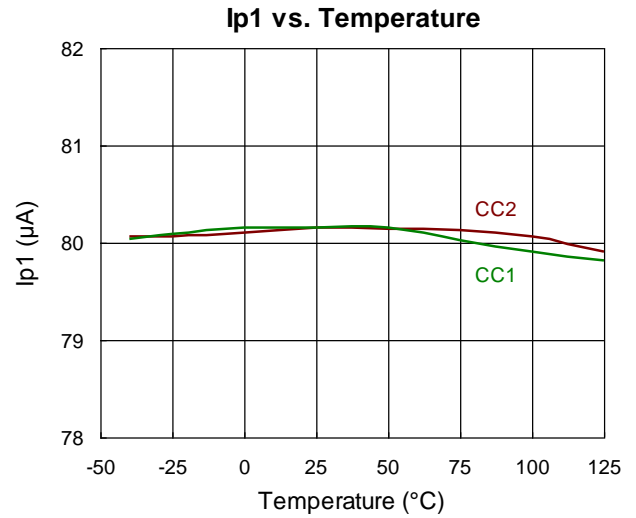
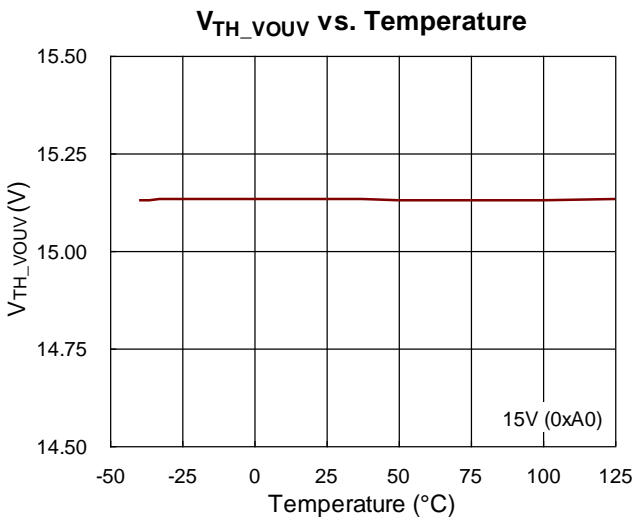
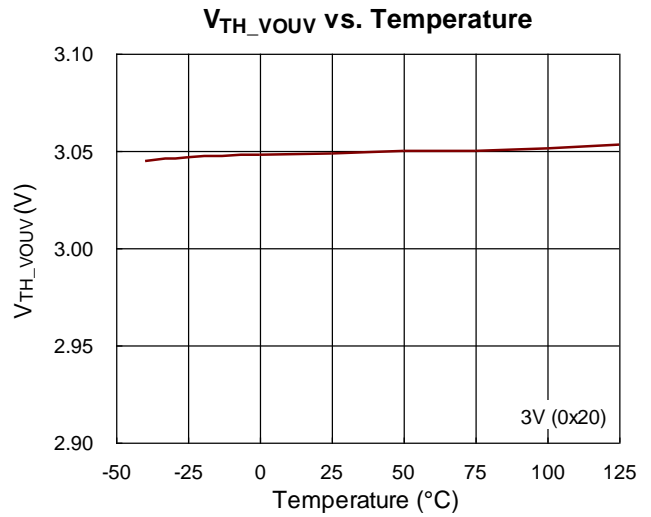
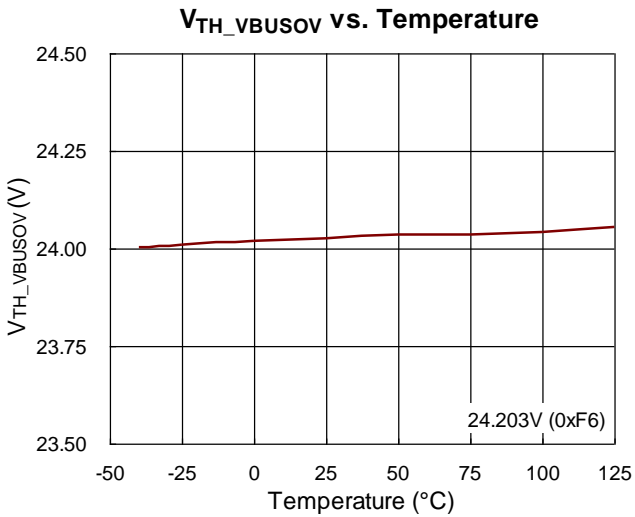
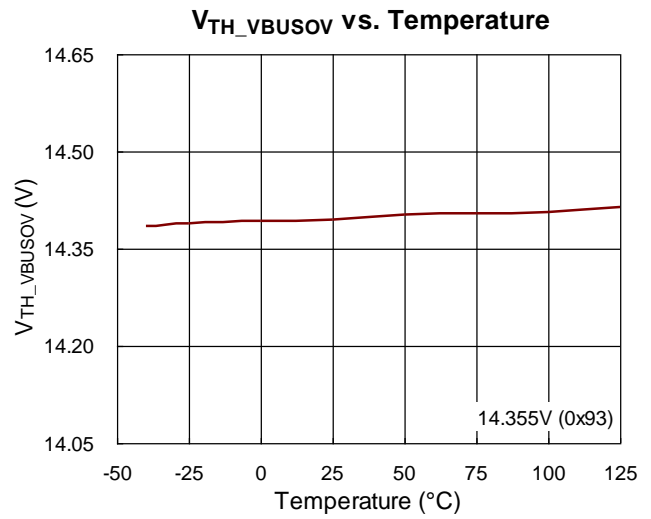
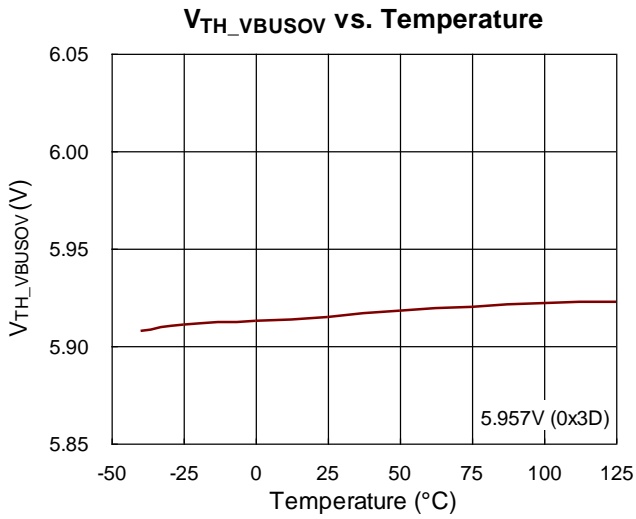



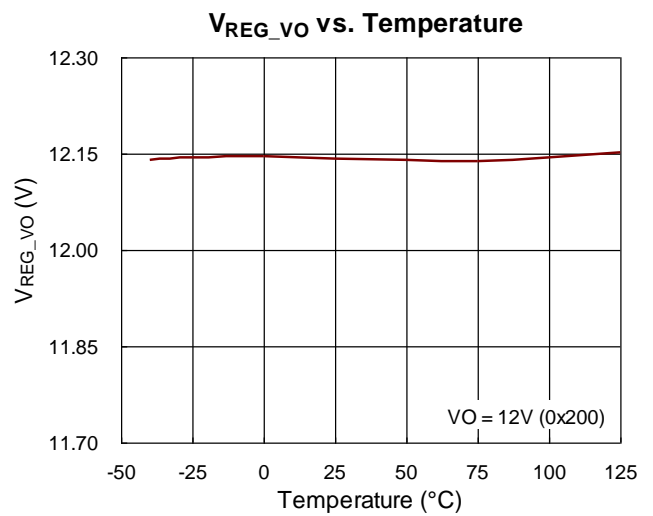
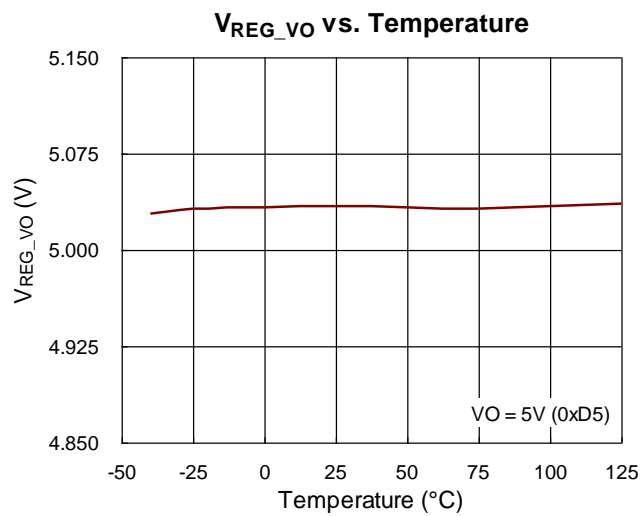
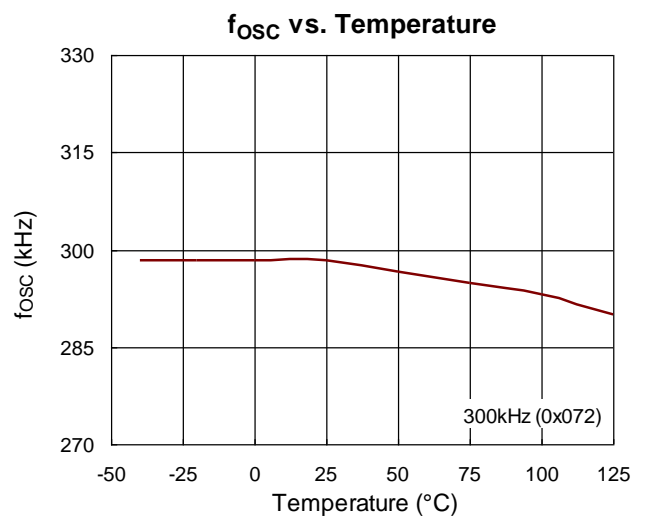
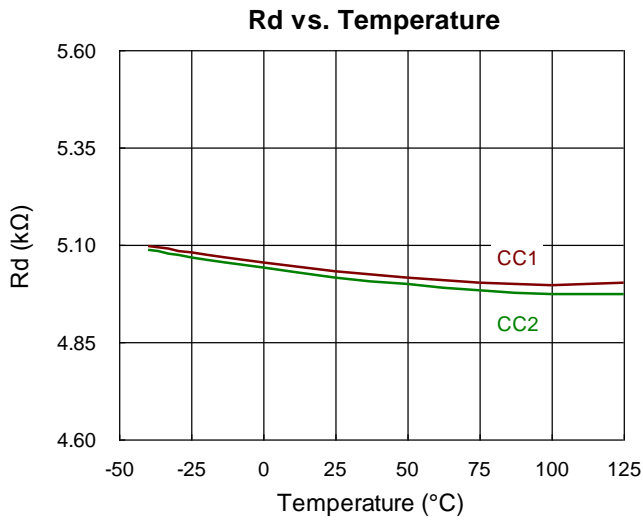
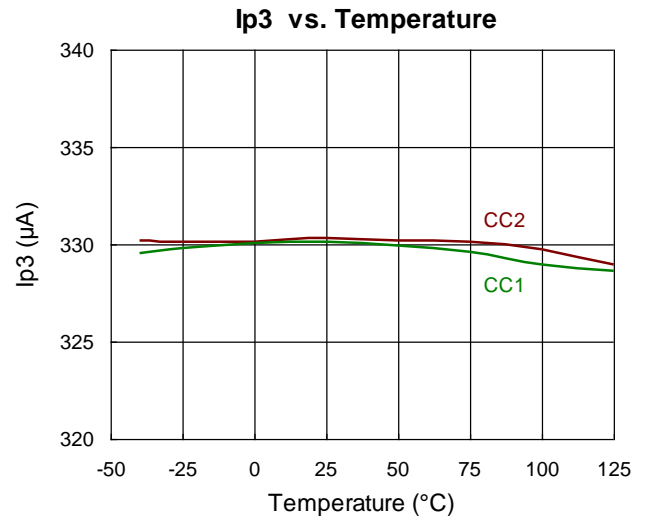
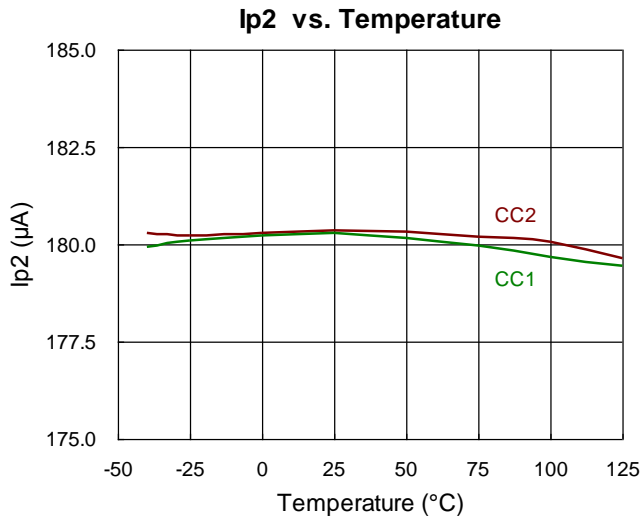

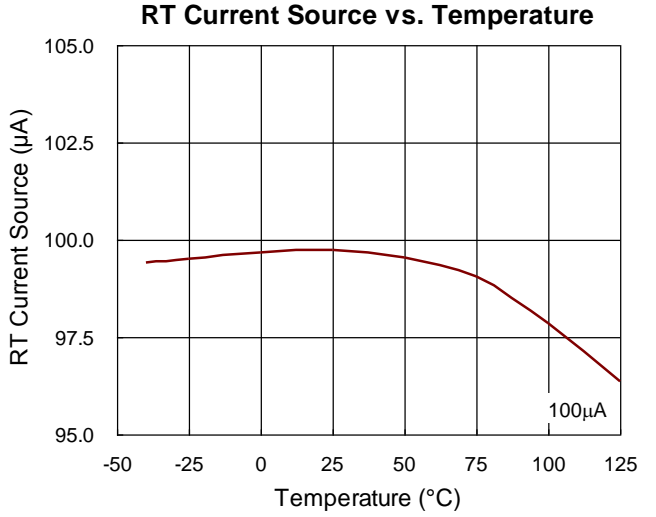
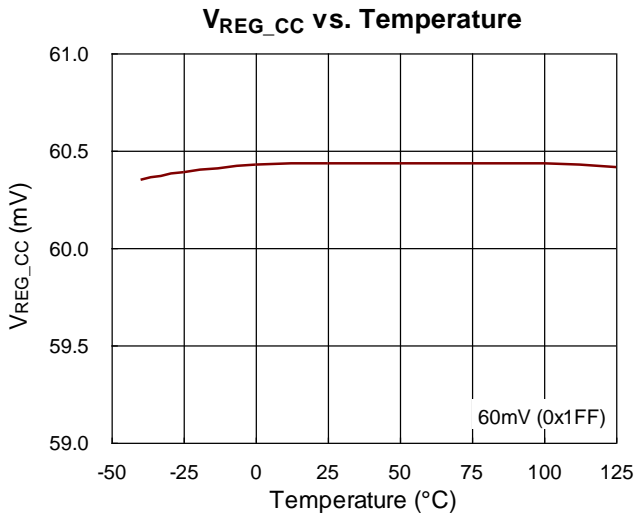
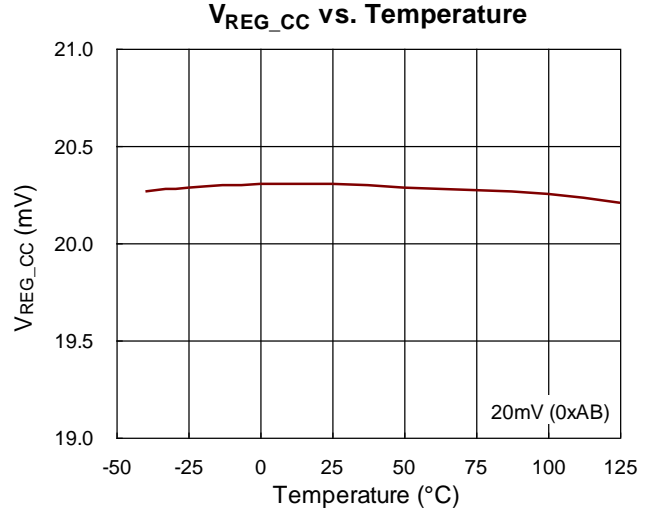
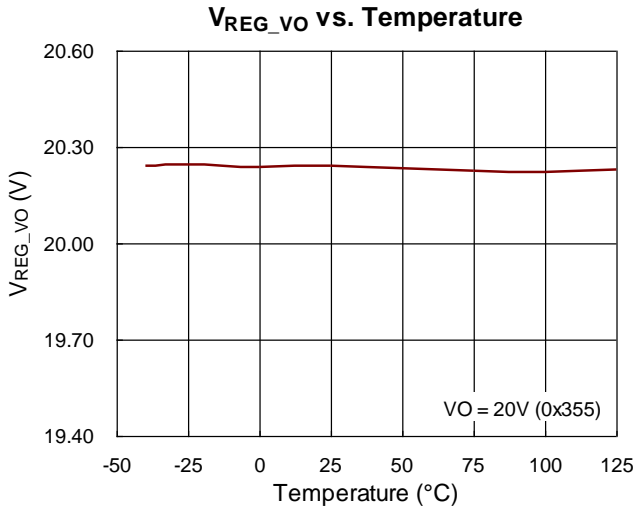

Application Information

Calculating Output Discharge Time

Figure 3 shows the functional block diagram of two built-in output bleeders at VBUS and BLD pins. The VBUS bleeder consists of an internal resistor (1.1kΩ typ.) and a pull-low MOSFET (QBLD2) for discharging the capacitors at VBUS side; the BLD bleeder consists of an external resistor (RBLD\_EXT) and a pull-low MOSFET (QBLD1) for discharging the capacitors at the output of the PWM converter. If the blocking MOSFETs (Q1A and Q1B) are on during discharging, the BLD bleeder with larger current capability dominates the discharge time. If the blocking MOSFETs are off, the discharge time (tDIS\_CVBUS) of the capacitor connected to the VBUS pin is determined by the following equation :

$$t_{DIS\_CVBUS} = R_{BLD\_INT} \times C_{VBUS} \times \ln\left(\frac{V_{BUS\_INI}}{V_{BUS\_FINAL}}\right)$$

where :

- ▶ RBLD\_INT is total internal resistance during on-state of the internal MOSFET QBLD2.
- ▶ CVBUS is the total capacitance, coupled to the VBUS pin.
- ▶ VBUS\_INI is the initial bus voltage before the discharging.
- ▶ VBUS\_FINAL is the final bus voltage at end of the discharging.

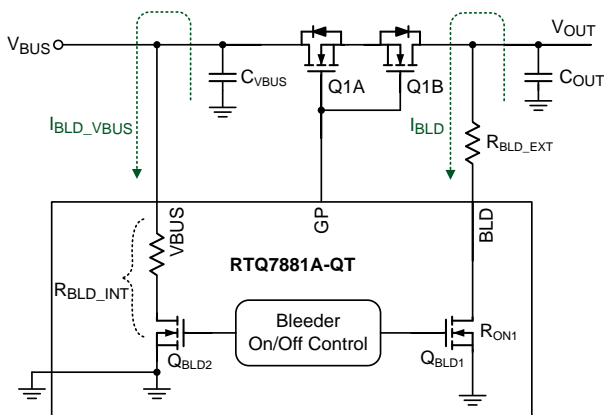

Figure 3. Functional Diagram of the Output Bleeders

Similar to the operation of the VBUS bleeder, the discharge time (tDIS\_COUT) of the capacitor connected to the output of the PWM converter is determined by the following equation :

$$t_{DIS\_COUT} = (R_{BLD\_EXT} + R_{ON1}) \times C_{OUT} \times \ln\left(\frac{V_{OUT\_INI}}{V_{OUT\_FINAL}}\right)$$

where :

- ▶ RBLD\_EXT is resistance of the external resistor.
- ▶ RON1 is on-resistance of the internal MOSFET QBLD1.
- ▶ COUT is the total capacitance connected to the output of the PWM converter.
- ▶ VOUT\_INI is the initial voltage of the PWM converter output before discharging.
- ▶ VOUT\_FINAL is the final voltage of the PWM converter output at end of discharging.

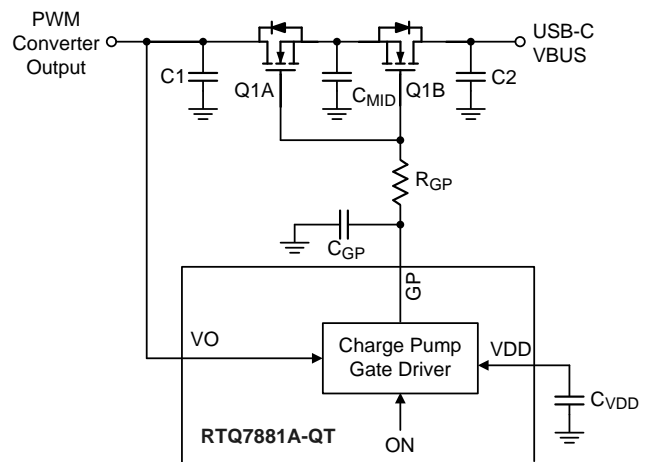

Figure 4. Functional Diagram of the Power-Path Control

Using Charge-Pump Gate Driver for Power-Path On/Off Control

Figure 4 shows the application schematic of a power-path on/off control. In this schematic, two N-channel MOSFETs of low on-resistance driven by a built-in gate driver, supplied by the charge pump, are employed to turn on or off the power-path between the PWM converter output and the USB-C VBUS terminal.

If the internal control signal “ON” goes high, the GP voltage ( $V_{GP}$ ) will be pulled high to turn on the power MOSFETs (Q1A and Q1B) and connect the power-path. If “ON” goes low,  $V_{GP}$  will be pulled low by a built-in MOSFET to disconnect the power-path.

Two power inputs (VO and VDD) are needed for the charge pump, and the VO pin must be connected the PWM converter output to ensure the power MOSFETs can be turned on successfully.

An optional MLCC capacitor ( $C_{GP}$ ) can be used to reduce the  $V_{GP}$  rising rate and surge current in the power path as the power MOSFETs being switched on. When the power MOSFETs being switched off, the parasitic inductor and capacitors, C1 or C2, on the power path may cause voltage ringing at the drain of the Q1A or Q1B. An optional gate resistor ( $R_{GP}$ ) can be added to reduce the falling rate of the power-path current and prevent voltage spikes. A  $1\mu\text{F}$  MLCC capacitor ( $C_{MID}$ ) between the source terminals to ground is necessary in order to prevent oscillation due to such dual-MOSFET connection.

### Thermal Considerations

The junction temperature should never exceed the absolute maximum junction temperature  $T_{J(MAX)}$ , listed under Absolute Maximum Ratings, to avoid permanent damage to the device. The maximum allowable power dissipation depends on the thermal resistance of the IC package, the PCB layout, the rate of surrounding airflow, and the difference between the junction and ambient temperatures. The maximum power dissipation can be calculated using the following formula :

$$P_{D(MAX)} = (T_{J(MAX)} - T_A) / \theta_{JA}$$

where  $T_{J(MAX)}$  is the maximum junction temperature,  $T_A$  is the ambient temperature, and  $\theta_{JA}$  is the junction-to-ambient thermal resistance.

For continuous operation, the maximum operating junction temperature indicated under Recommended Operating Conditions is  $125^\circ\text{C}$ . The junction-to-ambient thermal resistance,  $\theta_{JA}$ , is highly package dependent. For a WQFN-48L 6x6 package, the thermal resistance,  $\theta_{JA}$ , is  $26.8^\circ\text{C/W}$  on a standard JEDEC 51-7 high effective-thermal-conductivity four-layer test board. The maximum power dissipation at

$T_A = 25^\circ\text{C}$  can be calculated as below :

$$P_{D(MAX)} = (125^\circ\text{C} - 25^\circ\text{C}) / (26.8^\circ\text{C/W}) = 3.73\text{W for a WQFN-48L 6x6 package.}$$

The maximum power dissipation depends on the operating ambient temperature for the fixed  $T_{J(MAX)}$  and the thermal resistance,  $\theta_{JA}$ . The derating curves in Figure 5 allows the designer to see the effect of rising ambient temperature on the maximum power dissipation.

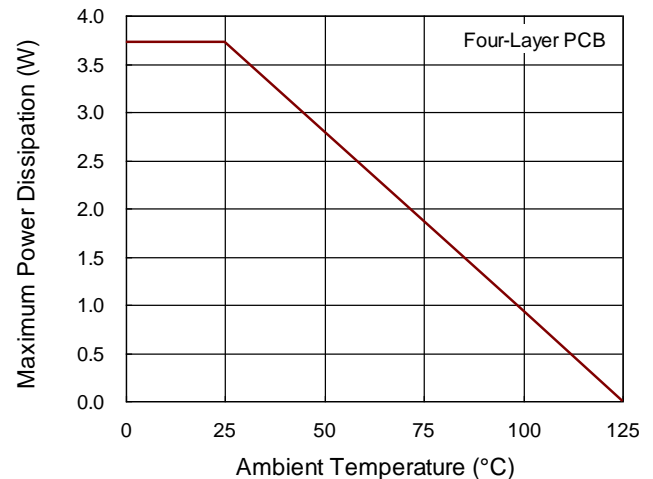

Figure 5. Derating Curve of Maximum Power Dissipation

### Layout Considerations

- ▶ Connect the IC GND pin and the exposed pad to a ground plane (IC-ground), and then connect the IC-ground to the USB GND terminals via a low-impedance path. The exposed pad is also used to dissipate the heat into PCB.
- ▶ Connect the decoupling MLCCs near the pins of VCONN, VDD, V2, PVDD and VBUS. Connect the MLCCs to the pins and IC-ground via low impedance paths.
- ▶ Connect the decoupling MLCC from the BOOT pin to the PHASE pin via a short and low-impedance path.
- ▶ Connect the PGND and PHASE pins respectively to the Source and the Drain of low-side power MOSFET (controlled by LGATE) via dedicated and low-impedance paths.

- ▶ Connect the GNDCC pin to GND terminals of the USB Type-C connector via dedicated and low-impedance path.
- ▶ Connect the capacitor (between the CSOP and CSON pins) close to these pins. The paths of CSOP and CSON must be directly connected to the terminals of current-sense resistor ( $R_{CSO}$ ) using Kelvin connections as shown in the layout shown in Figure 6.

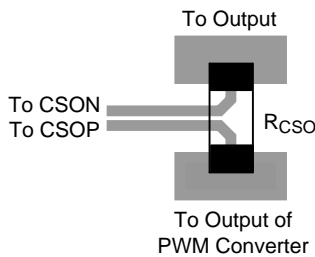

Figure 6. Kelvin Connections for the  $R_{CSO}$

- ▶ Figure 7 is a recommended placement of the PWM Buck power-stage. A critical loop from “ $C_{IN1} \rightarrow R_{CSI} \rightarrow Q_A \rightarrow Q_B$  to  $C_{IN1}$ ” must be as short as possible to minimize the switching noise at CSIP/VIN and CSIN pin. The short paths also reduce radiated EMI. It's necessary to use an MLCC ( $10\mu F/50V$ , X5R/X7R) for the input capacitor ( $C_{IN1}$ ). For reducing input and output voltage ripple during heavy load operation, it is recommended to add more MLCCs or solid input and output capacitors. To improve heat dissipation, increase the PCB areas for Drains of high-side and low-side MOSFETs.

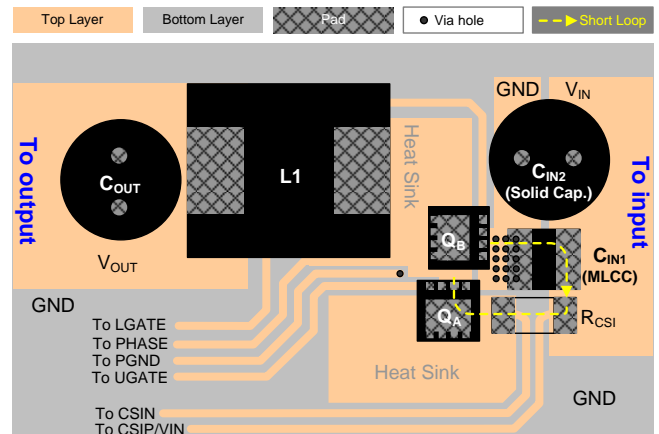

Figure 7. Recommended PCB Layout of the Power Stage

- ▶ Place the CV/CC loop compensation networks near the COMPV/COMPI pins and the IC-ground.
- ▶ To prevent the switching noises, separate the following signals from the switching nodes and the switching-current paths connected with PHASE pin :
  - Input and output current-sense signals;
  - CC1 and CC2 signals;
  - CV-loop feedback signal;
  - CV and CC compensation networks.
- ▶ For improving ESD immunity, connect MLCCs close to the GND and VBUS terminals of the USB Type-C connector. Connect the capacitors to the USB VBUS and GND terminals through the low-impedance paths.

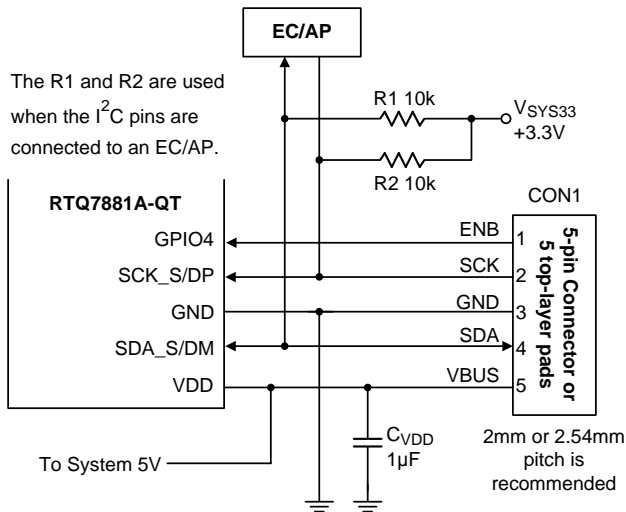

Figure 8. Connections for Manual Firmware Updates

## Manual Firmware Update

During product development stage, users might need to download or update the RTQ7881A-QT firmware. This can be done by adding a 5-pin connector (CON1) or five test pads on PCBs for updating the RTQ7881A-QT firmware manually as shown in Figure 8. This connector is then connected to a “RT7800 firmware update fixture” by a 5-pin cable. The fixture is also connected to a PC via a Micro USB cable and acts as a bridge between the RTQ7881A-QT and the PC. With this setup, users can download firmware to the RTQ7881A-QT by using the RTQ7881A-QT graphic user interface (GUI) installed in the PC. During the firmware update process, the fixture can supply current (up to 40mA) to the RTQ7881A-QT and the system 5V via the VBUS pin of the 5-pin cable.

If the power from the fixture is enough to power the RTQ7881A-QT and the system 5V, it is not necessary to use the auxiliary input voltage for the system 5V. On the other hand, if the system 5V consumes more current than the fixture capability, one needs to use an auxiliary input voltage.

**Outline Dimension**

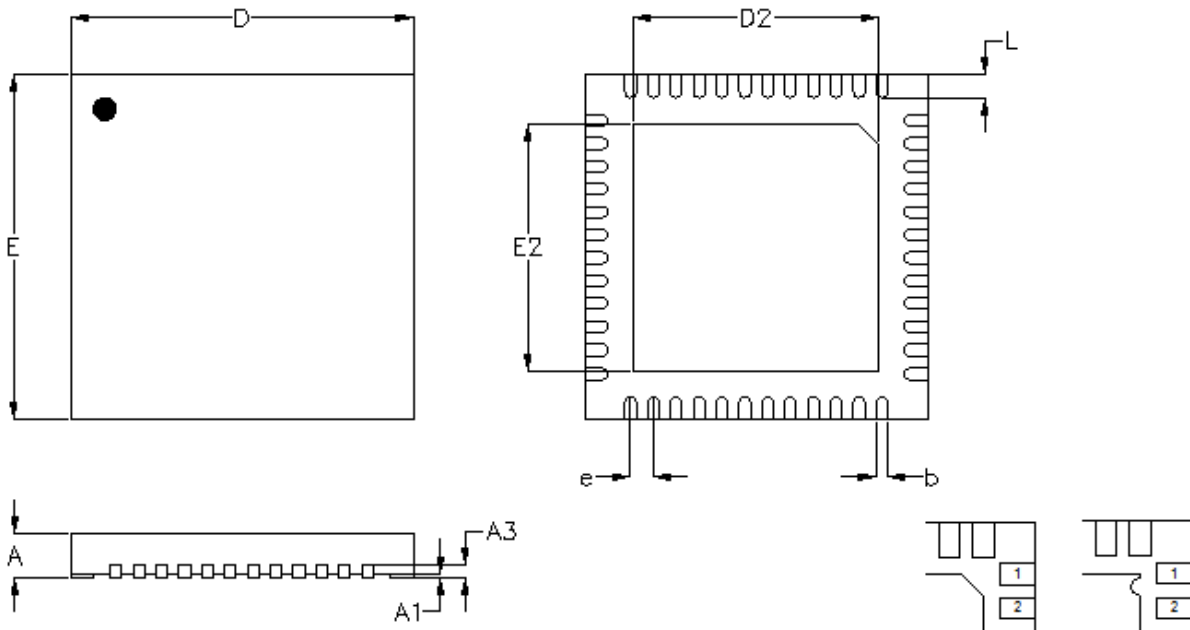

**DETAIL A**

Pin #1 ID and Tie Bar Mark Options

Note : The configuration of the Pin #1 identifier is optional, but must be located within the zone indicated.

Symbol	Dimensions In Millimeters		Dimensions In Inches		
	Min	Max	Min	Max	
A	0.700	0.800	0.028	0.031	
A1	0.000	0.050	0.000	0.002	
A3	0.175	0.250	0.007	0.010	
b	0.150	0.250	0.006	0.010	
D	5.950	6.050	0.234	0.238	
D2	Option 1	4.250	4.350	0.167	0.171
	Option 2	4.350	4.450	0.171	0.175
	Option 3	4.650	4.750	0.183	0.187
E	5.950	6.050	0.234	0.238	
E2	Option 1	4.250	4.350	0.167	0.171
	Option 2	4.350	4.450	0.171	0.175
	Option 3	4.650	4.750	0.183	0.187
e	0.400		0.016		
L	0.350	0.450	0.014	0.018	

**W-Type 48L QFN 6x6 Package**

Footprint Information

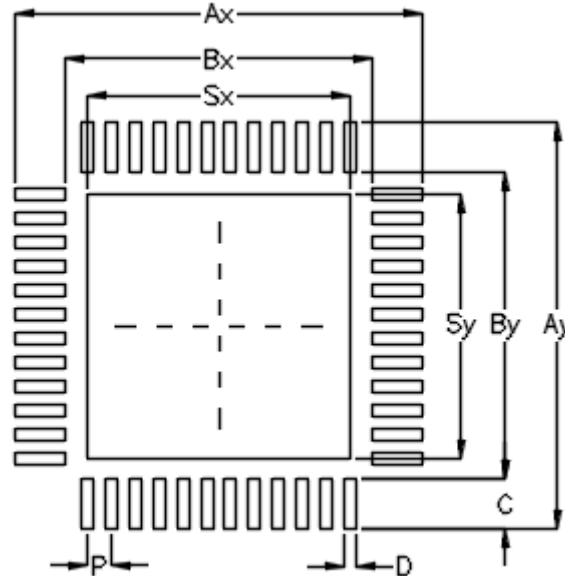

Package		Number of Pin	Footprint Dimension (mm)								Tolerance	
			P	Ax	Ay	Bx	By	C	D	Sx		Sy
V/W/U/XQFN6x6-48	Option1	48	0.40	6.80	6.80	5.10	5.10	0.85	0.20	4.40	4.40	±0.05
	Option2									4.50	4.50	
	Option3									4.70	4.70	

Richtek Technology Corporation

14F, No. 8, Tai Yuen 1<sup>st</sup> Street, Chupei City  
 Hsinchu, Taiwan, R.O.C.  
 Tel: (8863)5526789

RICHTEK

Richtek products are sold by description only. Richtek reserves the right to change the circuitry and/or specifications without notice at any time. Customers should obtain the latest relevant information and data sheets before placing orders and should verify that such information is current and complete. Richtek cannot assume responsibility for use of any circuitry other than circuitry entirely embodied in a Richtek product. Information furnished by Richtek is believed to be accurate and reliable. However, no responsibility is assumed by Richtek or its subsidiaries for its use; nor for any infringements of patents or other rights of third parties which may result from its use. No license is granted by implication or otherwise under any patent or patent rights of Richtek or its subsidiaries.

Copyright © 2021 Richtek Technology Corporation. All rights reserved. RICHTEK is a registered trademark of Richtek Technology Corporation.

www.richtek.com

DSQ7881A-QT-00 July 2021



单击下面可查看定价，库存，交付和生命周期等信息

[>>Richtek\(台湾立锜\)](#)