

BRIGHT LED ELECTRONICS CORP.

BL-HJE33-AV-TRB

● Features:

1. Emitted Color: Super Orange Red.
2. Lens Appearance : Water Clear
3. Mono-color type.
4. 3.2x1.6x1.1mm(1206) standard package
5. Suitable for all SMT assembly methods.
6. Compatible with infrared and vapor phase reflow solder process.
7. Compatible with automatic placement equipment.
8. This product doesn't contain restriction Substance, comply ROHS standard.

● Applications:

1. Automotive : Dashboards, stop lamps, turn signals.
2. Backlighting : LCDs, Key pads advertising.
3. Status indicators : Consumer & industrial electronics.
4. General use.

● Package Dimensions:

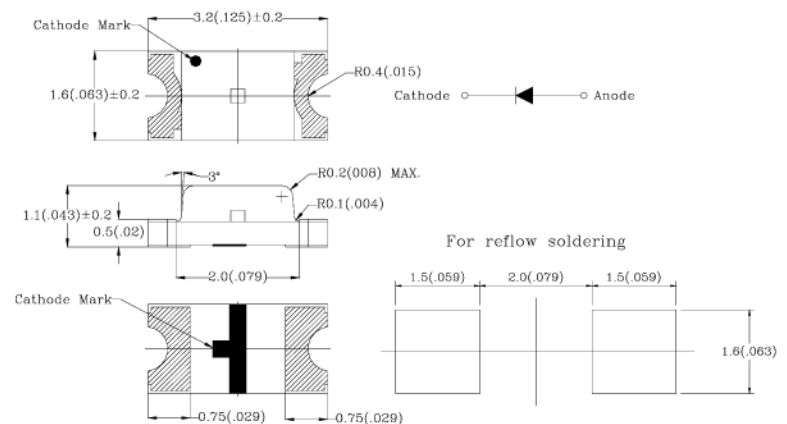

NOTES:

1. All dimensions are in millimeters (inches).
2. Tolerance is $\pm 0.10\text{mm}$ (0.004") unless otherwise specified.
3. Specifications are subject to change without notice.

● Absolute Maximum Ratings(Ta=25°C)

| Parameter | Symbol | Rating | Unit |
|--------------------------|-----------------|------------|------|
| Power Dissipation | Pd | 100 | mW |
| Forward Current | I _F | 30 | mA |
| Peak Forward Current * 1 | I _{FP} | 100 | mA |
| Reverse Volage | V _R | 5 | V |
| Operating Temperature | Topr | -40°C~85°C | - |
| Storage Temperature | Tstg | -40°C~85°C | - |
| Soldering Temperature | Tsol | See Page 6 | - |

* 1 Condition for I_{FP} is pulse of 1/10 duty and 0.1msec width.

BRIGHT LED ELECTRONICS CORP.

BL-HJE33-AV-TRB

● Electrical and optical characteristics(Ta=25°C)

| Parameter | Symbol | Condition | Min. | Typ. | Max. | Unit |
|--------------------------|-------------------|----------------------|------|------|------|------|
| Forward Voltage | V _f | I _F =20mA | - | 2.0 | 2.6 | V |
| Luminous Intensity | I _v | I _F =20mA | 63 | 100 | - | mcd |
| Peak Wave Length | λ _p | I _F =20mA | - | 630 | - | nm |
| Dominant Wave Length | λ _d | I _F =20mA | 615 | - | 625 | nm |
| Spectral Line Half-width | Δλ | I _F =20mA | - | 17 | - | nm |
| Viewing Angle | 2θ _{1/2} | I _F =20mA | - | 120 | - | deg |

● Typical Electro-Optical Characteristics Curves

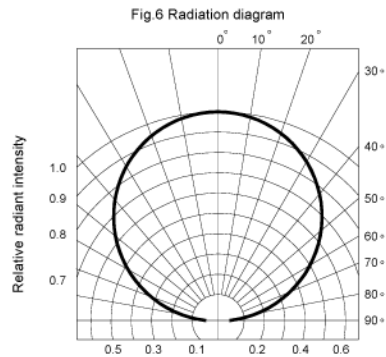
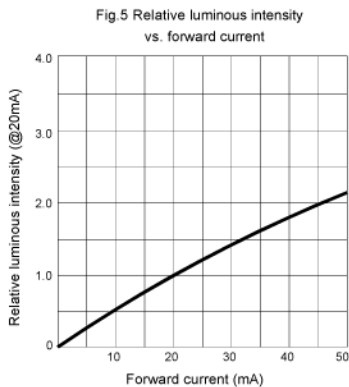
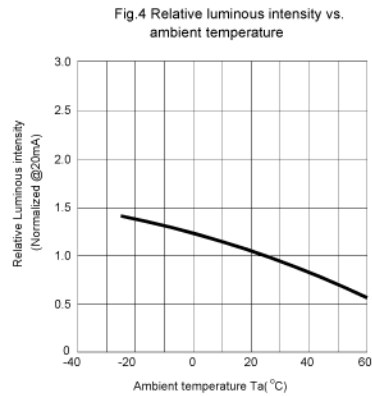
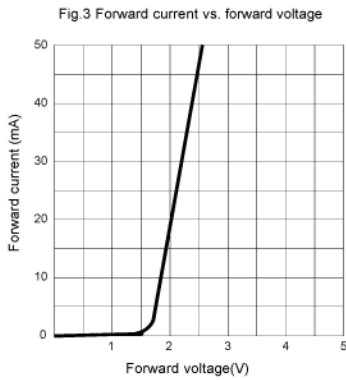
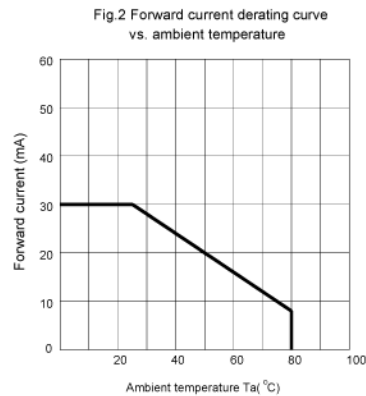
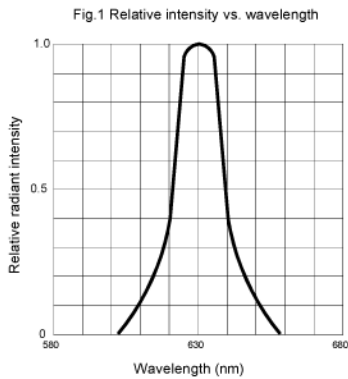

BRIGHT LED ELECTRONICS CORP.

BL-HJE33-AV-TRB

● Tapping and packaging specifications(Units: mm)

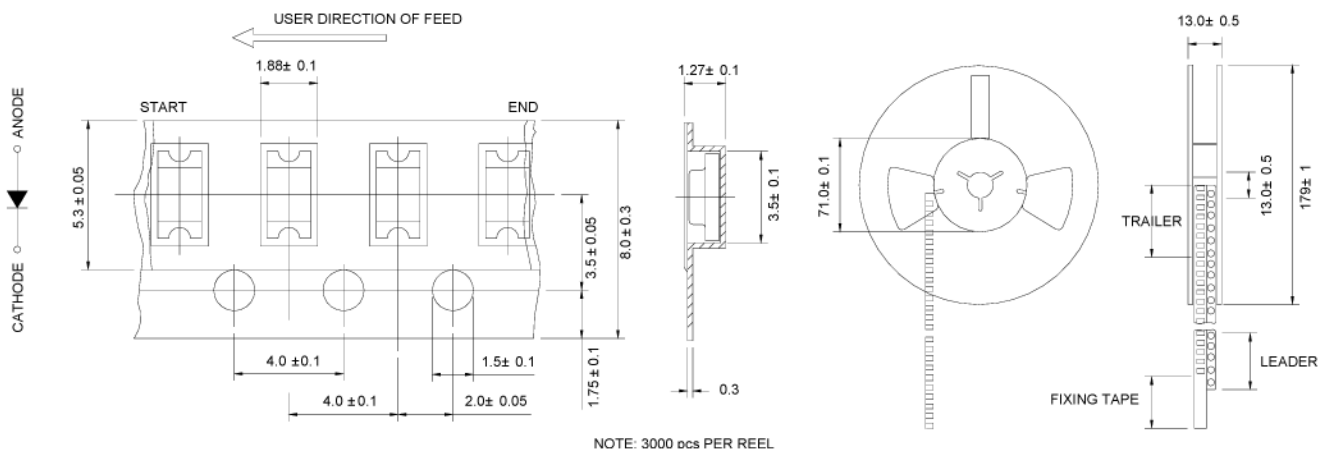

● Package Method:(unit:mm)Vacuum

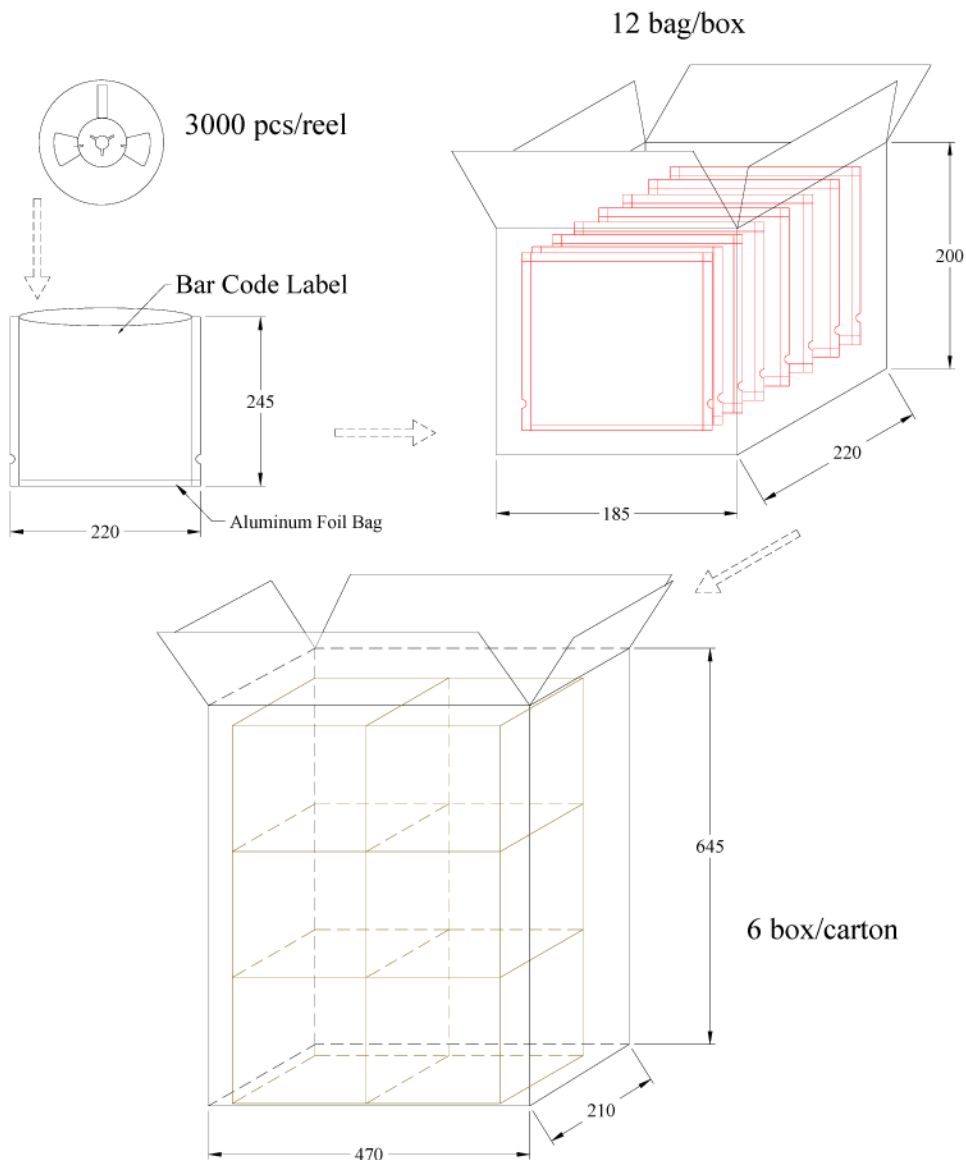

BRIGHT LED ELECTRONICS CORP.

BL-HJE33-AV-TRB

● Bin Limits

Intensity Bin Limits (At 20mA)

| BIN CODE | Min. (mcd) | Max. (mcd) |
|----------|------------|------------|
| P | 63 | 94 |
| Q | 94 | 140 |
| R | 140 | 210 |
| S | 210 | 317 |

Tolerance for each Bin limit is $\pm 15\%$

Color Bin Limits (At 20mA)

| BIN CODE | Min. (nm) | Max. (nm) |
|----------|-----------|-----------|
| * | 615 | 625 |

Tolerance for each Bin limit is $\pm 1\text{ nm}$.

V_F Bin Limits (At 20mA)

| BIN CODE | Min.(v) | Max.(v) |
|----------|---------|---------|
| B | 1.8 | 2.0 |
| C | 2.0 | 2.2 |
| D | 2.2 | 2.4 |
| E | 2.4 | 2.6 |

Tolerance for each Bin limit is $\pm 0.05\text{ V}$.

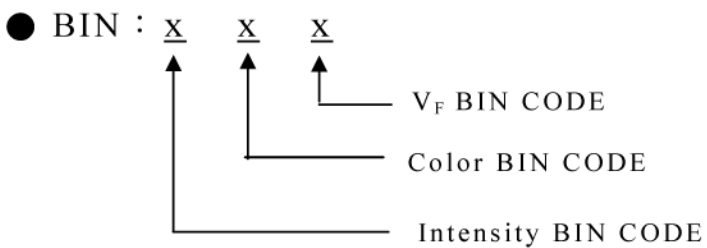

BRIGHT LED ELECTRONICS CORP.

BL-HJE33-AV-TRB

● Reliability Test

| Classification | Test Item | Reference Standard | Test Conditions | Result |
|-----------------------|--|--|--|--------|
| urance Test | Operation Life | MIL-STD-750D:1026 MIL-STD-883D:1005 JIS-C-7021 :B-1 | Connect with a power $I_f=20\text{mA}$ T_a =Under room temperature Test time=1,000hrs | 0/20 |
| | High Temperature High Humidity Storage | MIL-STD-202F:103B JIS-C-7021 :B-11 | $T_a=+85^\circ\text{C}\pm 5^\circ\text{C}$ RH=90%-95% Test time=240hrs | 0/20 |
| | High Temperature Storage | MIL-STD-883:1008 JIS-C-7021 :B-10 | High $T_a=+100^\circ\text{C}\pm 5^\circ\text{C}$ Test time=1,000hrs | 0/20 |
| | Low Temperature Storage | JIS-C-7021 :B-11 | Low $T_a=-40^\circ\text{C}\pm 5^\circ\text{C}$ Test time=1,000hrs | 0/20 |
| Environmental Test | Temperature Cycling | MIL-STD-202F:107D MIL-STD-750D:1051 MIL-STD-883D:1010 JIS-C-7021 :A-2 | $-35^\circ\text{C}\pm 5^\circ\text{C} \sim +25^\circ\text{C} \sim +85^\circ\text{C}\pm 5^\circ\text{C} \sim +25^\circ\text{C}$ 30min 5min 30min 5min Test Time=10cycle | 0/20 |
| | Thermal Shock | MIL-STD-202F:107D MIL-STD-750D:1051 MIL-STD-883D:1011 | $-40^\circ\text{C}\pm 5^\circ\text{C} \sim +85^\circ\text{C}\pm 5^\circ\text{C}$ 20min 20min Test Time=10cycle | 0/20 |
| | Solder Resistance | MIL-STD-202:201A MIL-STD-750:2031 JIS-C-7021 :A-1 | Preheating : $140^\circ\text{C}-160^\circ\text{C}$, within 2 minutes. Operation heating : 260°C (Max.), within 10seconds. (Max.) | 0/20 |

● Judgment criteria of failure for the reliability

| Measuring items | Symbol | Measuring conditions | Judgement criteria for failure |
|--------------------|-------------------------|----------------------|--------------------------------|
| Forward voltage | V_F (V) | $I_F=20\text{mA}$ | Initial Level*1.1 |
| Reverse current | I_R (μA) | $V_R=5\text{V}$ | Over U*2 |
| Luminous intensity | I_v (mcd) | $I_F=20\text{mA}$ | Initial Level*0.7 |

Note: 1.U means the upper limit of specified characteristics.

2.Measurment shall be taken between 2 hours and after the test pieces have been returned to normal ambient conditions after completion of each test.

BRIGHT LED ELECTRONICS CORP.

BL-HJE33-AV-TRB

● Soldering :

1. Manual Of Soldering

The temperature of the iron tip should not be higher than 300°C (572°F) and Soldering within 3 seconds per solder-land is to be observed.

2. Reflow Soldering

Preheating : 140°C~160°C ±5°C ,within 2 minutes.

Operation heating : 260°C (Max.) within 10 seconds.(Max)

Gradual Cooling (Avoid quenching).

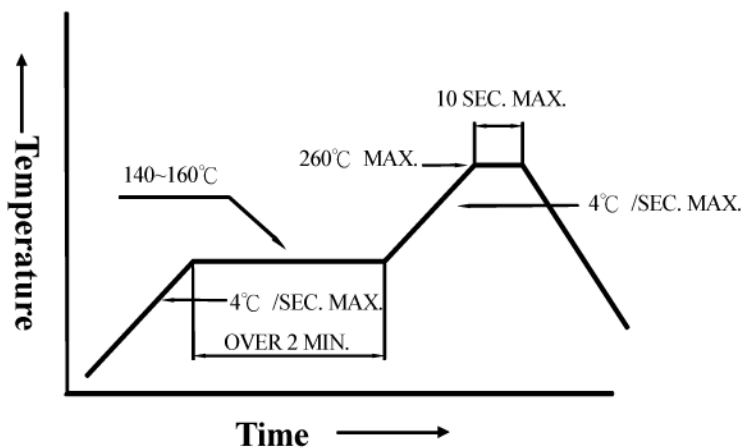

3. DIP soldering (Wave Soldering) :

Preheating : 120°C~150°C ,within 120~180 sec.

Operation heating : 245°C ±5°C within 5 sec. 260°C (Max)

Gradual Cooling (Avoid quenching).

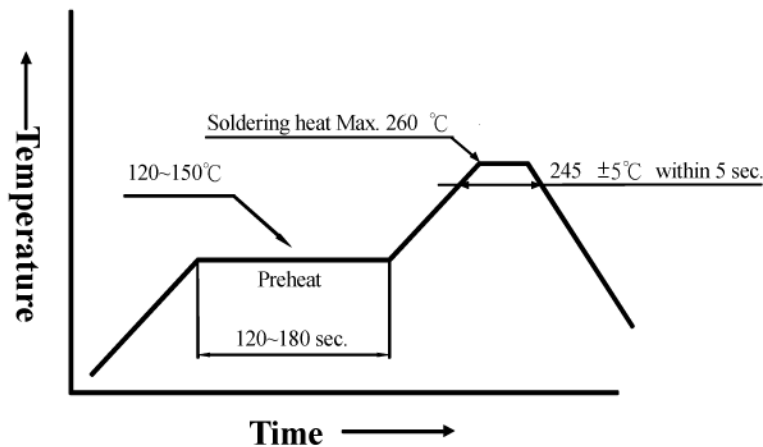

● Handling :

Care must be taken not to cause to the epoxy resin portion of BRIGHT LEDs while it is exposed to high temperature.

Care must be taken not rub the epoxy resin portion of BRIGHT LEDs with hard or sharp article such as the sand blast and the metal hook.

单击下面可查看定价，库存，交付和生命周期等信息

[>>BRT\(佰鸿工业\)](#)