



High Speed Low Dropout Middle Current Voltage Regulators

Description

The VIC3116 series are highly precise, low noise, positive voltage LDO regulators manufactured using CMOS processes. The series achieves high ripple rejection and low dropout and consists of a standard voltage source, an error correction, current limiter and a phase compensation circuit plus a driver transistor. Output voltage is selectable in 100mV increments within a range of 1.5V ~ 5.0V. The series is also compatible with low ESR ceramic capacitors which give added output stability. This stability can be maintained even during load fluctuations due to the excellent transient response of the series.

The current limiter's feedback circuit also operates as a short protect for the output current limiter and the output pin. The CE function enables the output to be turned off, resulting in greatly reduced power

Features

- Output voltage range : 1.0V to 5.0V (selectable in 100mV steps)
- Highly accurate : $\pm 2\%$
- Dropout voltage : 300mV @ 100mA (3.0V type)
- High ripple rejection : 70dB (1 kHz)
- Low power consumption : 70 μ A (TYP.)
- Maximum output current : 300mA
- Standby current : less than 2 μ A
- Internal protector : current limiter and short protector

Applications

- Mobile phones
- Cameras, Video cameras
- Portable games
- Cordless phones and radio communication Equipment
- Portable AV equipment
- PDAs

Ordering Information

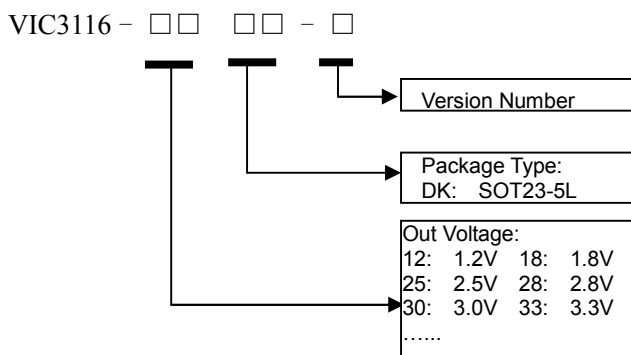

Pin Assignment

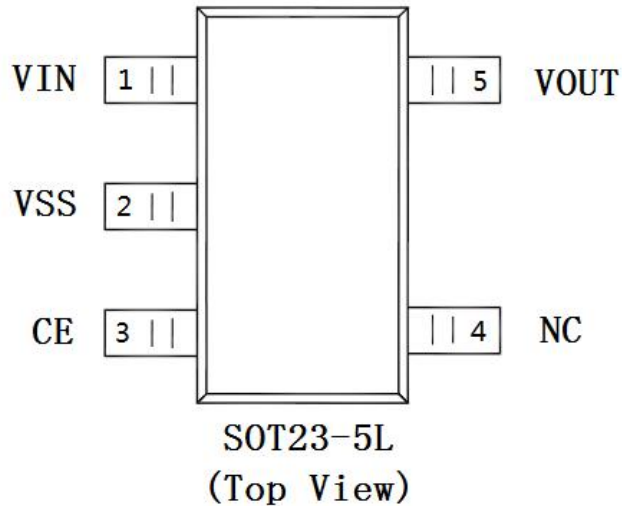

Function Pin Description

Pin Name	Pin Description
VIN	Power Input
VSS	Ground.
CE	Enable pin
NC	NC
OUT	Voltage output

Absolute Maximum Ratings

Vin	-----	VSS-0.3V~VSS+8V
Von/off, VOUT	-----	VSS-0.3V~VIN+0.3V
Iout1+Iout2	-----	350mA
P _D (SOT23-5L)	-----	400mW
Operating Ambient Temperature	-----	-40°C~+85°C
Storage Temperature	-----	-40°C~125°C

Caution: The absolute maximum ratings are rated values exceeding which the product could suffer physical damage. These values must therefore not be exceeded under any conditions.



VIC3116DK-B

Electrical Characteristic

Parameter	Symbol	Condition	Min	Typ	Max	Unit	Circuit
Output Voltage	$V_{OUT(E)}$	$V_{IN} = V_{OUT(S)} + 1.0 \text{ V}$, $I_{OUT} = 30 \text{ mA}$	$V_{OUT(S)} \times 0.98$	$V_{OUT(S)}$	$V_{OUT(S)} \times 1.02$	V	1
Output Current	I_{OUT}	$V_{IN} \geq V_{OUT(S)} + 1.0 \text{ V}$	300	--	--	mA	
Dropout Voltage	V_{drop}	$I_{OUT} = 50 \text{ mA}$	--	0.12	0.20	V	
		$I_{OUT} = 100 \text{ mA}$	--	0.30	0.45		
Line Regulations	$\Delta V_{OUT1} / (\Delta V_{IN} * \Delta V_{OUT1})$	$V_{OUT(S)} + 0.5 \text{ V} \leq V_{IN} \leq 7 \text{ V}$ $I_{OUT} = 10 \text{ mA}$	--	0.1	0.2	%/V	
Load Regulation	ΔV_{OUT2}	$V_{IN} = V_{OUT(S)} + 1.0 \text{ V}$ $1.0 \text{ mA} \leq I_{OUT} \leq 100 \text{ mA}$	--	50	100	mV	
Output Voltage Temperature characteristics	$\Delta V_{OUT} / (\Delta T_a * \Delta V_{OUT})$	$V_{IN} = V_{OUT(S)} + 1.0 \text{ V}$, $I_{OUT} = 10 \text{ mA}$ $-40^\circ \text{C} \leq T_a \leq 85^\circ \text{C}$	--	± 100	--	ppm/ $^\circ \text{C}$	
Supply Current	I_{SS1}	$V_{IN} = V_{OUT(S)} + 1.0 \text{ V}$	--	70	--	μA	2
Standby Current	I_{STB}	$V_{IN} = V_{EN} = V_{OUT(T)} + 1 \text{ V}$, $V_{EN} = V_{SS}$	--	0.01	0.1	μA	3
Input Voltage	V_{IN}		2.0	--	7.0	V	--
Ripple-Rejection	PSRR	$V_{IN} = V_{OUT(S)} + 1.0 \text{ V}$, $f = 1 \text{ kHz}$ $V_{rip} = 0.5 \text{ V}_{rms}$, $I_{OUT} = 50 \text{ mA}$	--	70	--	dB	1
Short-circuit Current	I_{short}	$V_{IN} = V_{OUT(S)} + 1.0 \text{ V}$, $V_{IN} = V_{EN}$	--	40	--	mA	
CE "High" Voltage	V_{CEH}	--	1.6	--	V_{IN}	V	2
CE "Low" Voltage	V_{CEL}	--	--	--	0.25	V	
CE "High" Current	I_{CEH}	$V_{IN} = V_{EN} = V_{OUT(T)} + 1 \text{ V}$	-0.1	--	0.1	μA	
CE "Low" Current	I_{CEL}	$V_{IN} = V_{EN} = V_{OUT(T)} + 1 \text{ V}$, $V_{EN} = V_{SS}$	-0.1	--	0.1	μA	

Test Circuits

Circuit 1

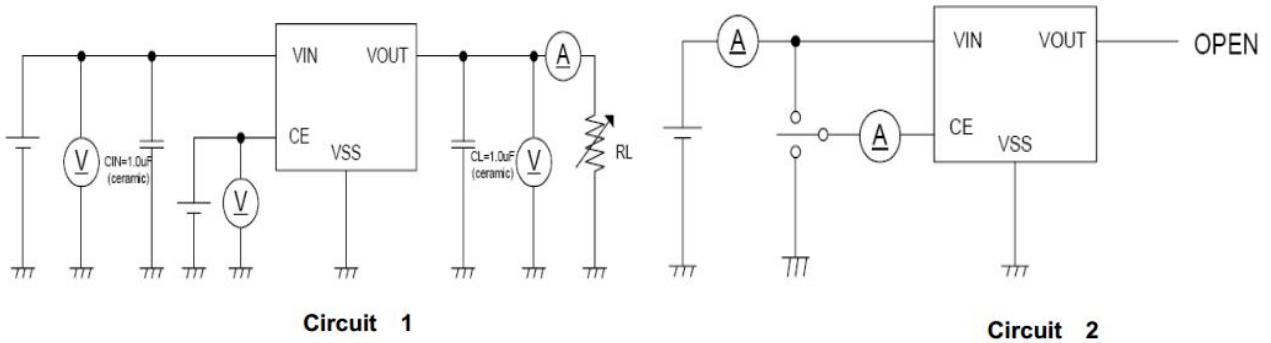

Block Diagram

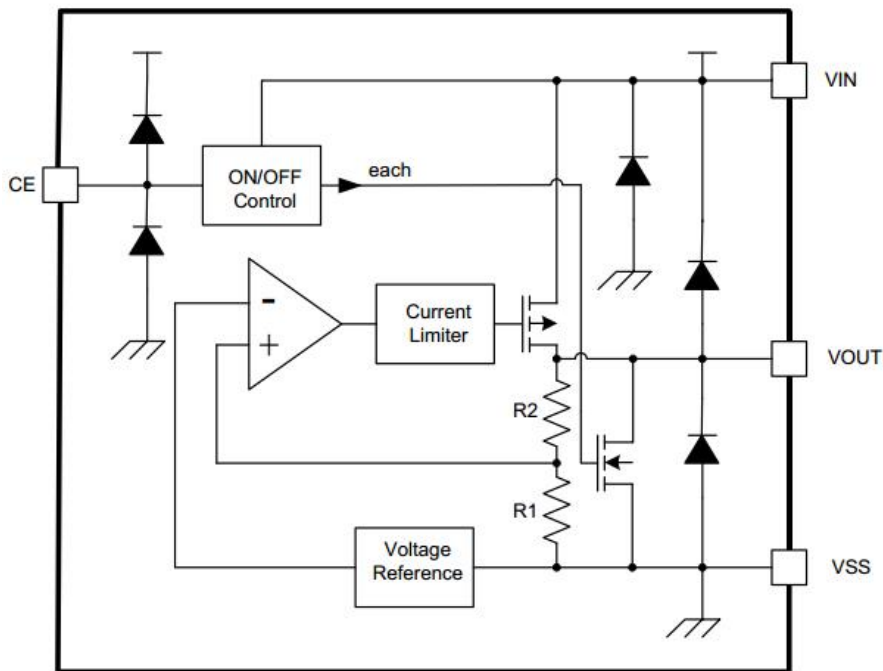
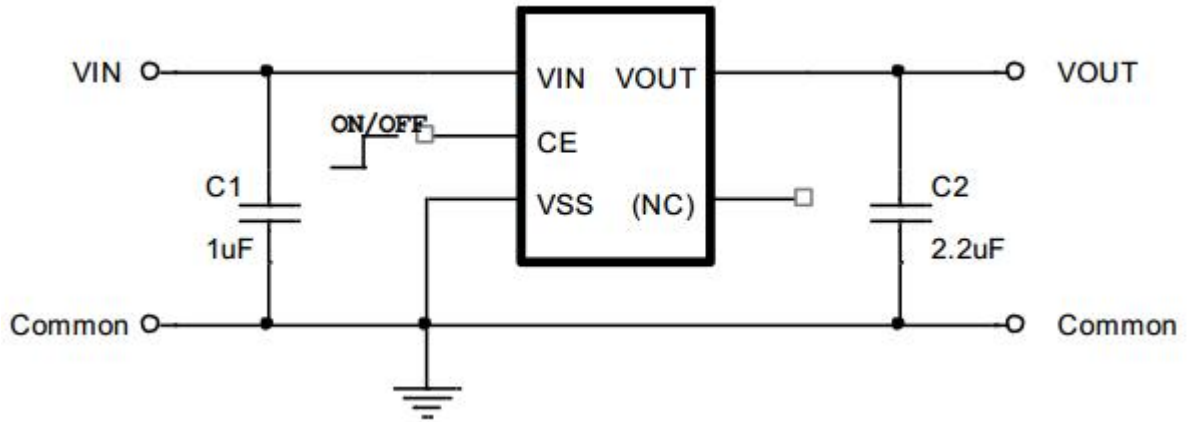

Figure 1 VIC3116 Functional Block Diagram

Typical Application Circuit



Caution: The above connection diagram and constant will not guarantee successful operation. Perform thorough evaluation using the actual application to set the constant.

Application Conditions

input capacitor (C_{IN}): 1.0µF or more

Output capacitor (C_L): 1.0µF or more (tantalum capacitor)

Caution A general series regulator may oscillate, depending on the external components selected. Check that no oscillation occurs with the application using the above capacitor.

Typical Performance Characteristics (3.0V output)

1、 Output Voltage vs. Output Current

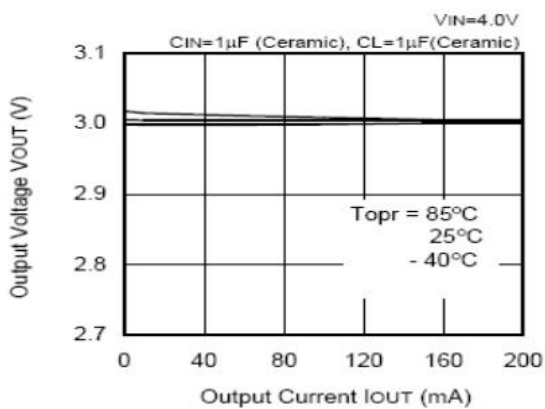

2、 Output Voltage vs. Input Voltage (Contd.)

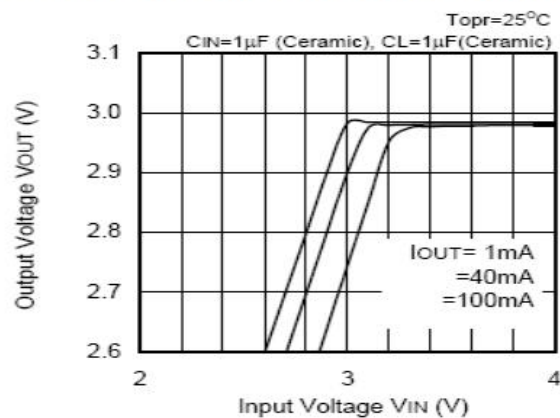

3、Dropout Voltage vs. Output Current

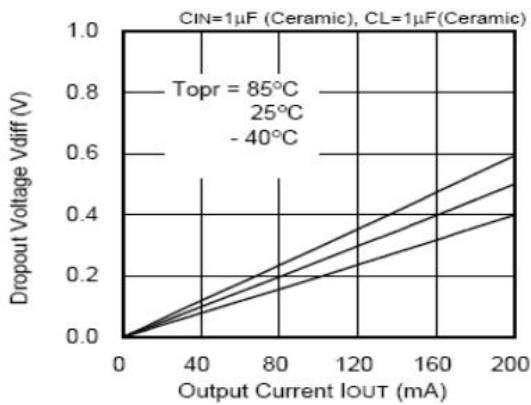

4、Dropout Voltage vs. Output Voltage

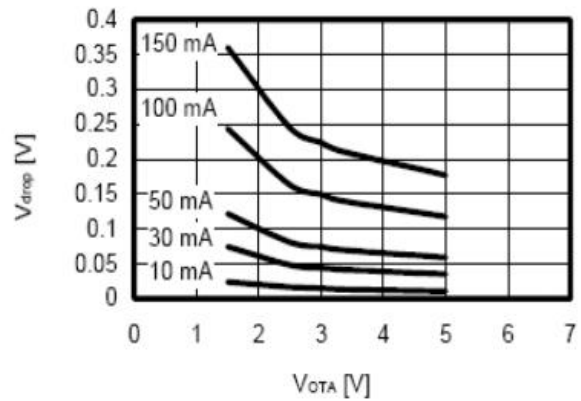

5、Output Voltage vs. Ambient Temperature

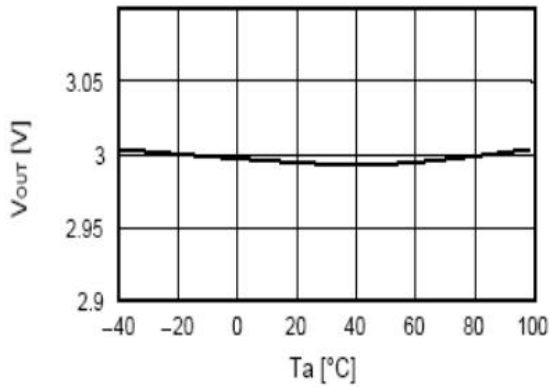

6、Ripple Rejection Rate

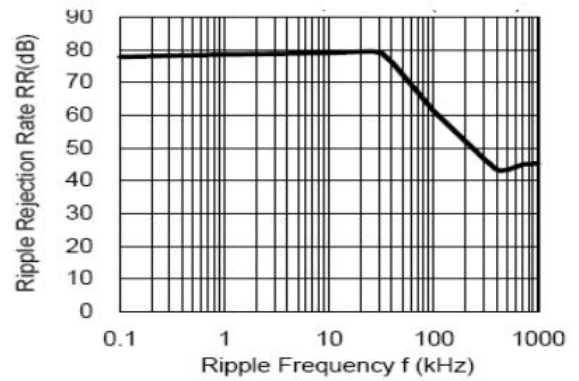

7、Transient Response

Input Transient Response

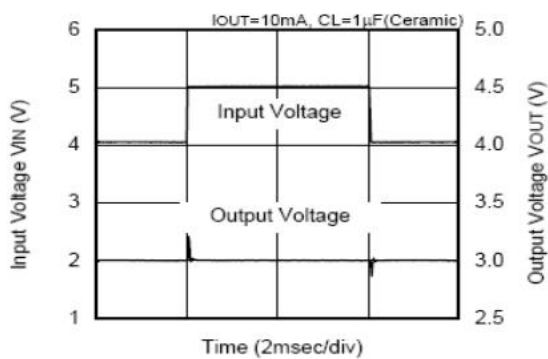

Load Transient Response

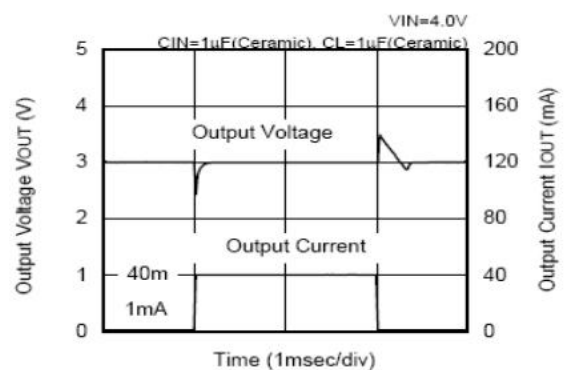



VIC3116DK-B

ORDERING INFORMATION

Part Number	Package code	Shipping
VIC3116-XXDK-B	DK: SOT23-5L	3000/Tape & Reel

PACKAGE DIMENSIONS (SOT23-5L)

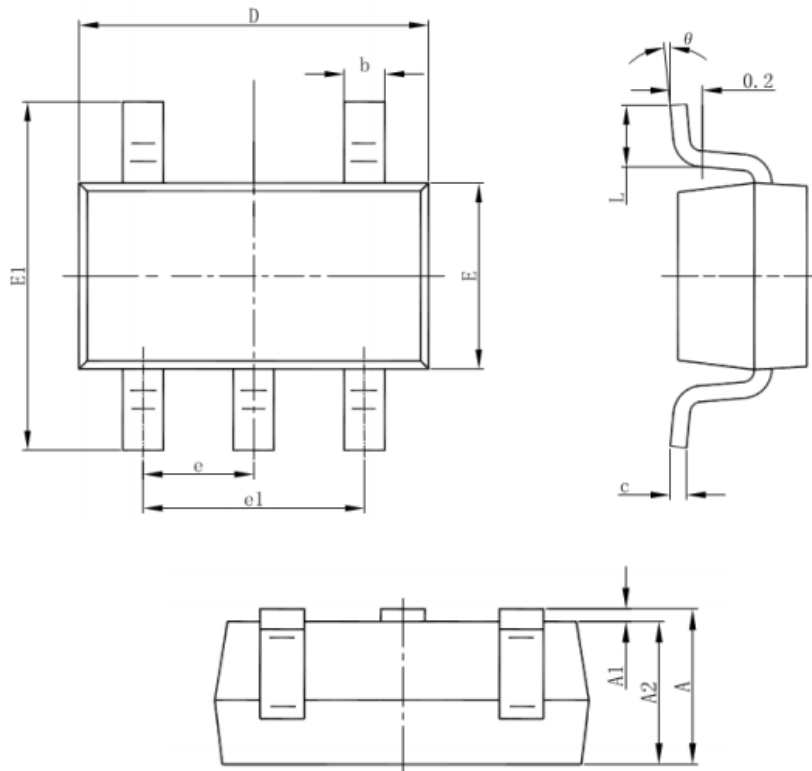

Symbol	Dimensions In Millimeters		Dimensions In Inches	
	Min	Max	Min	Max
A	1.050	1.250	0.041	0.049
A1	0.000	0.100	0.000	0.004
A2	1.050	1.150	0.041	0.045
b	0.300	0.500	0.012	0.020
c	0.100	0.200	0.004	0.008
D	2.820	3.020	0.111	0.119
E	1.500	1.700	0.059	0.067
E1	2.650	2.950	0.104	0.116
e	0.950(BSC)		0.037(BSC)	
e1	1.800	2.000	0.071	0.079
L	0.300	0.600	0.012	0.024
θ	0°	8°	0°	8°

单击下面可查看定价，库存，交付和生命周期等信息

[>>VIC\(微科\)](#)