

FEATURES

- Wide Input Voltage from 2.5V to 6V
- Adjustable Output Voltage from 0.8V to VIN
- 3A Continuous Output Current
- Constant on Time (COT) Control
- Forced Continuous Conduction Mode (FCCM) for Light Load
- Stable with low ESR Ceramic Capacitors
- 2.5MHz Switching Frequency
- 17μA Low Quiescent Current
- 100% Duty Cycle Operation for Low Dropout
- Junction Temperature Range from -40°C to 125°C
- Internal Soft-Start time 2.5ms
- Power Good (PG) Indicator
- Cycle-by-Cycle Output Current Limit Protection
- Short Circuit and Over-Load Hiccup Protection
- Thermal Shutdown Protection
- LGA-13 (2.5mm×2.5mm×1.24mm) Package
- Pb-Free RoHS Compliant

APPLICATIONS

- Optical Module
- PoL Power Supply
- Solid-State and Hard Disk Drives

DESCRIPTION

The M0503 is a 3A step-down switching mode Power SoC (System on Chip) with integrated power MosFETs, inductor and input decoupling capacitor in LGA-13 package. The input voltage is from 2.5V to 6V and the switching frequency is fixed at 2.5MHz.

The M0503 provides high efficiency with COT control mode for fast transient response and good loop stability. It works on FCCM which keeps low output ripple and supports 100% duty cycle for low dropout.

The M0503 indicates faults by PG and provides short circuit and over-load hiccup protection and over temperature shutdown protection.

TYPICAL APPLICATION & EFFICIENCY

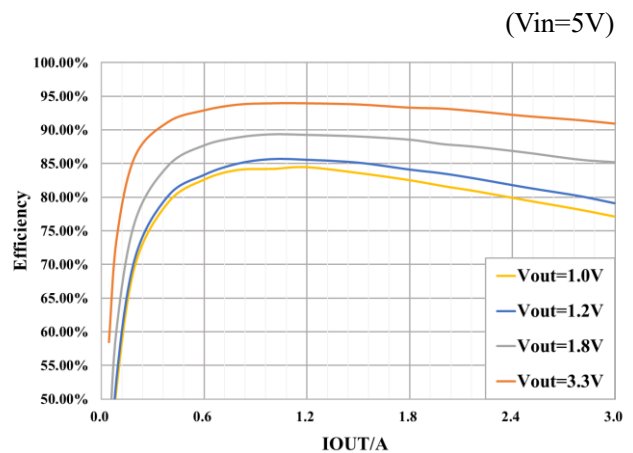
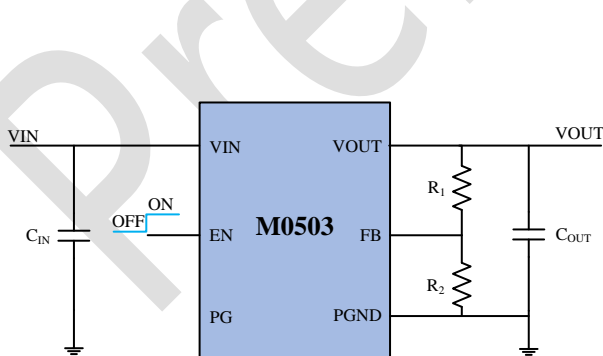



ORDERING INFORMATION

PART NUMBER	TOP MARKING	PACKAGE	MOQ	MSL LEVEL
M0503DLBGP	M0503 YWWLLL	LGA-13 (2.5mm×2.5mm×1.24mm)	3000/ Tape & Reel	3
M0503DLBG ^{Note 1)}	M0503 YWWLLL ^{Note 2)}	LGA-13 (2.5mm×2.5mm×1.24mm)	3000/ Tape & Reel	3

NOTES:

- 1) M0503DLBG is not recommended for new design.
- 2) Y: Year, WW: Week, LLL: Lot Number.

PACKAGE REFERENCE

TOP VIEW	
<p>VOUT VOUT VOUT VOUT</p> <p>12 11 10 9</p> <p>PGND 1 13 PGND 8 FB</p> <p>NC 2 7 PG</p> <p>3 4 5 6</p> <p>VIN VIN VIN EN</p>	<p>VOUT VOUT VOUT VOUT</p> <p>12 11 10 9</p> <p>PGND 1 13 PGND 8 FB</p> <p>NC 2 7 PG</p> <p>3 4 5 6</p> <p>VIN VIN VIN EN</p>
<p>LGA-13 M0503DLBGP</p>	<p>LGA-13 M0503DLBG (Not recommended for new design)</p>

**PIN FUNCTIONS**

PIN #	NAME	DESCRIPTION
1,13	PGND	Power Ground.
2	NC	Not Connected.
3,4,5	VIN	Input Voltage. VIN supplies power to all the internal control circuitry and the power switch. A decoupling capacitor to PGND is recommended to be placed close to VIN directly.
6	EN	Enable Control. Pull this pin low shuts the chip down. Pull it up high enables the chip.
7	PG	Power Good. The output of PG is an open drain, a pull-up resistor to power source is needed if used. If the chip works normally, PG is pulled high, else, PG is latched low.
8	FB	Feedback. Connect this pin with an external resistor divider from the output to PGND to set the output voltage.
9,10,11,12	VOUT	Output Voltage. Connect this pin with the load. Output capacitor is recommended to be placed between VOUT and PGND.



FUNCTIONAL BLOCK DIAGRAM

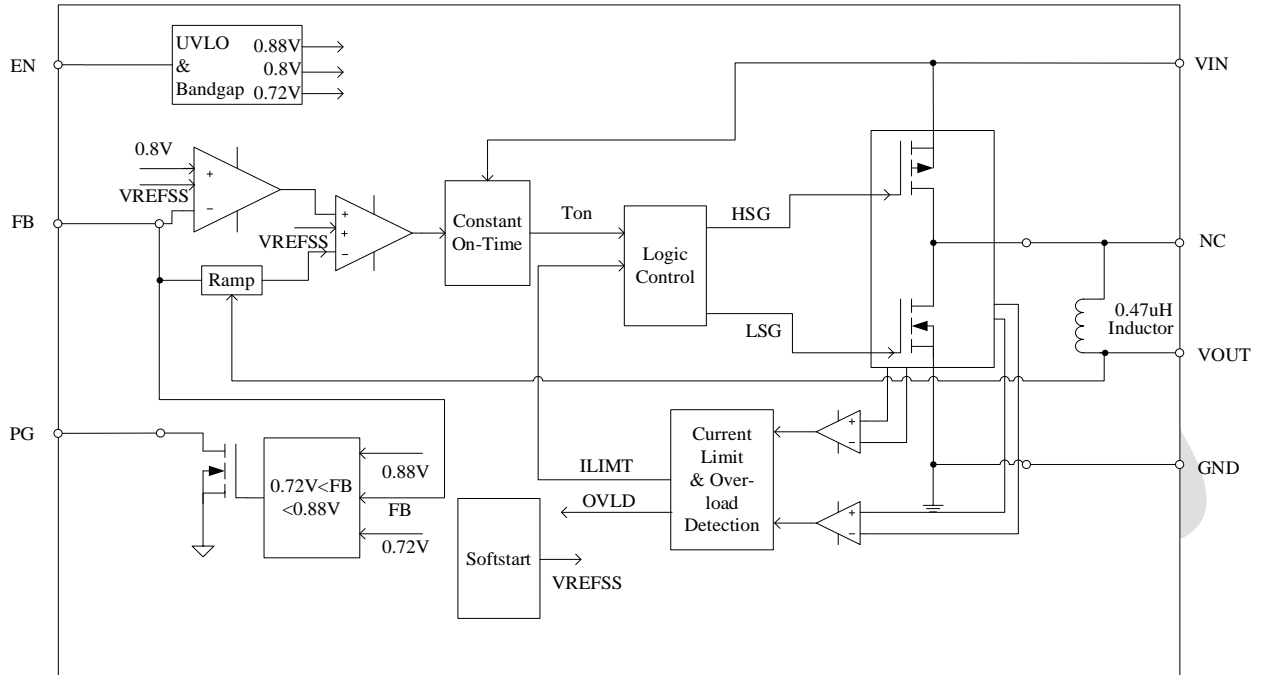



ABSOLUTE MAXIMUM RATINGS

	SYMBOL	MIN	MAX	UNIT
Voltage at Pins	V_{IN}	-0.3	6.5	V
Voltage at Other Pins		-0.3	6	V
Junction Temperature Range	T_J	-40	125	°C
Storage Temperature Range	T_S	-55	125	°C
Solder Reflow Body Temperature Range			245	°C
Power Dissipation ($T_A=+25^{\circ}\text{C}$)	P_D ^{Note 1)}		1.7	W

RECOMMENDED OPERATING CONDITIONS

	SYMBOL	MIN	MAX	UNIT
Input Voltage Range	V_{IN}	2.5	5.5	V
Output Voltage Range	V_{OUT}	0.8	V_{IN}	V
Output Current	I_{OUT}		3	A
Junction Temperature Range	T_J	-40	125	°C

THERMAL RESISTANCE

	SYMBOL	MIN	MAX	UNIT
Junction to Ambient	θ_{JA} ^{Note 2)}		58.5	°C/W
Junction to Case	θ_{JC} ^{Note 2)}		2	°C/W

NOTES:

- 1) The maximum allowable continuous power dissipation at any ambient temperature (T_A) is calculated by $P_D(\text{max})=(T_J(\text{max})-T_A)/\theta_{JA}$. Exceeding the maximum allowable power dissipation will cause excessive die temperature, and the power module will go into thermal shutdown.
- 2) Measured on EVB, 2-layer PCB 1oZ.

**ELECTRICAL CHARACTERISTICS**

$V_{IN}=5V$, $T_A=25^{\circ}C$, unless otherwise noted. Typical values are at $V_{EN}=3.6V$ and $V_{OUT}=1.2V$.

PARAMETERS	SYMBOL	CONDITION	MIN	TYP	MAX	UNIT
Input Voltage	V_{IN}		2.5		6.0	V
Input under Voltage Lockout Threshold	V_{UVLO}	V_{IN} Increasing		2.4		V
Input under Voltage Lockout Hysteresis				270		mV
Input over Voltage Lockout Threshold	V_{OVLO}	V_{IN} Increasing		6.6		V
Input over Voltage Lockout Hysteresis				410		mV
Shutdown Current	I_{SD}	$V_{EN}=0$, $V_{IN}=5.5V$		0.1	5	μA
Quiescent Current (No Switching)	I_Q	$V_{FB}=0.63V$		17		μA
EN On Threshold		V_{EN} Increasing		1.21		V
EN Off Threshold		V_{EN} Decreasing		1.1		V
EN Internal Pull-Down Resistor				1000		k Ω
Feedback Voltage	V_{FB_REF}		792	800	808	mV
HS Switch Current Limit				5		A
Switching Frequency	F_{SW}			2.5		MHz
Soft-Start Time	T_{SS}			2.5		ms
PG Output Low Voltage		$V_{FB}=5V$, sink 1mA		0.2	0.3	V
PG Under Voltage Rise Threshold		V_{FB} in respect to the regulation	-12	-10	-8	%
PG Under Voltage Fall Threshold		V_{FB} in respect to the regulation		-13		%
PG Delay	T_{PG_DELAY}			30		μs
Thermal Shutdown				160		$^{\circ}C$
Thermal Shutdown Hysteresis				30		$^{\circ}C$



TYPICAL PERFORMANCE CHARACTERISTICS

$V_{IN}=5V$, $T_A=25^{\circ}C$, $F_{SW}=2.5MHz$, $V_{OUT}=1.2V$, unless otherwise noted.

Line Regulation

$V_{OUT}=1.2V$, $I_{OUT}=3A$, $V_{IN}=2.5\sim 6V$

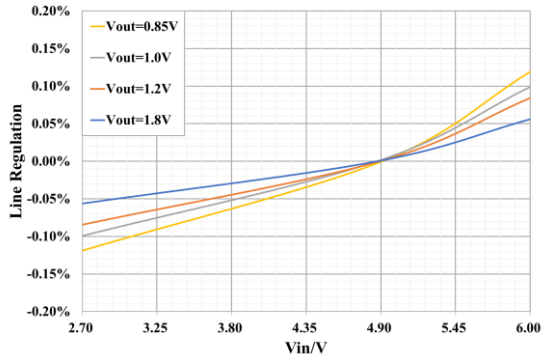

Load Regulation

$V_{IN}=5V$, $V_{OUT}=1.2V$, $I_{OUT}=0\sim 3A$

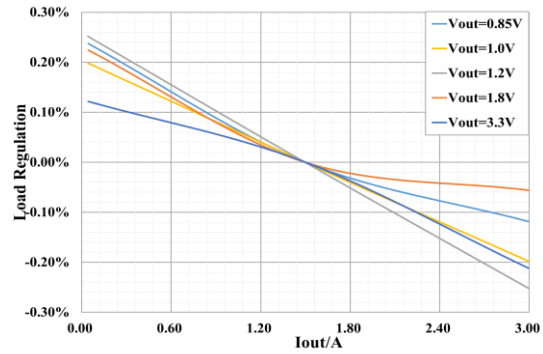

Efficiency

$V_{IN}=5V$, $V_{OUT}=1.0V/1.2V/1.8V/3.3V$,

$I_{OUT}=0\sim 3A$

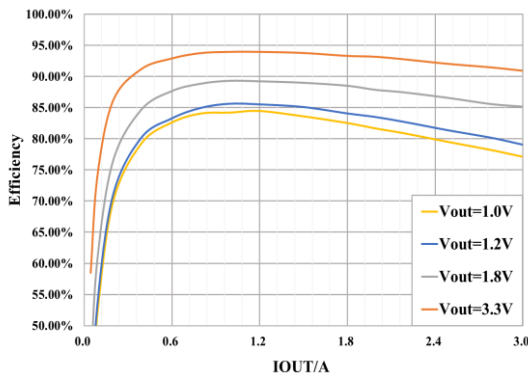

Efficiency

$V_{IN}=3.3V$, $V_{OUT}=0.85V/1.0V/1.2V/1.8V$,

$I_{OUT}=0\sim 3A$

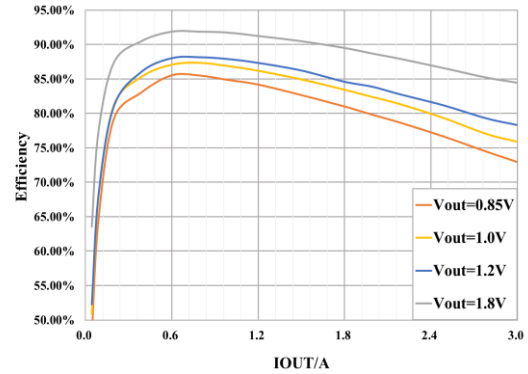



TYPICAL PERFORMANCE CHARACTERISTICS (continued)

$V_{IN}=5V$, $T_A=25^{\circ}C$, $F_{SW}=2.5MHz$, $V_{OUT}=1.2V$, unless otherwise noted.

VIN Start-up

$I_{OUT}=0A$

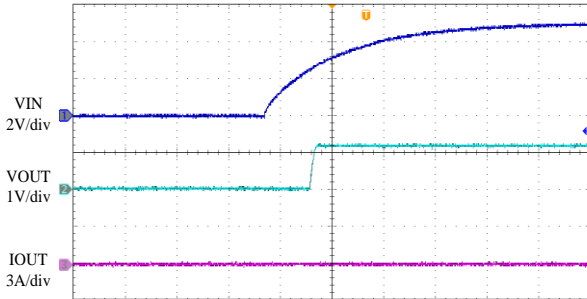

20ms/div

VIN Start-up

$I_{OUT}=3A$

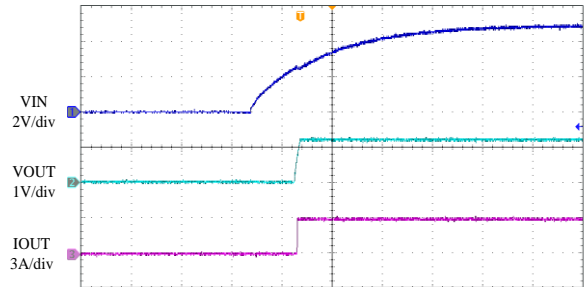

20ms/div

VIN Shutdown

$I_{OUT}=0A$

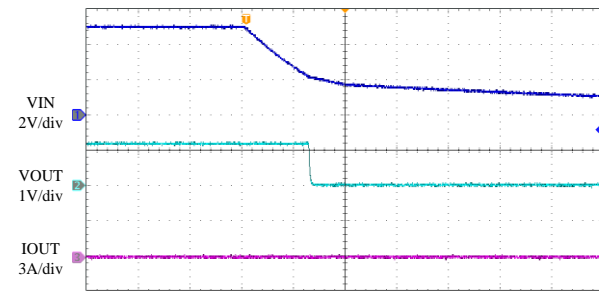

20ms/div

VIN Shutdown

$I_{OUT}=3A$

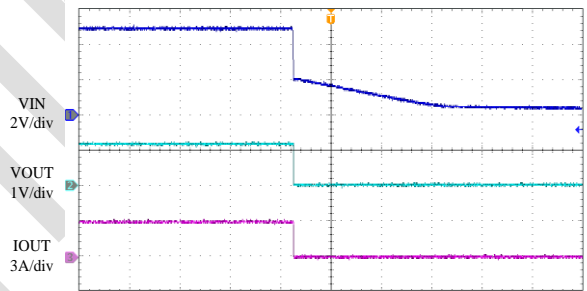

20ms/div

EN Start-up

$I_{OUT}=0A$

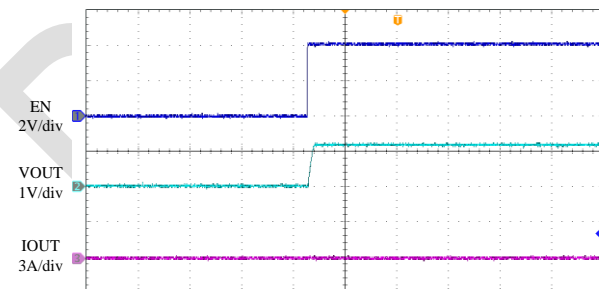

20ms/div

EN Start-up

$I_{OUT}=3A$

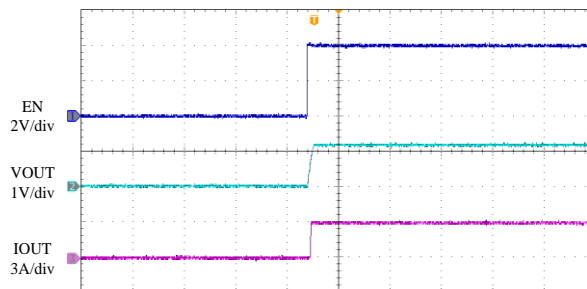

20ms/div



TYPICAL PERFORMANCE CHARACTERISTICS (continued)

$V_{IN}=5V$, $T_A=25^{\circ}C$, $F_{SW}=2.5MHz$, $V_{OUT}=1.2V$, unless otherwise noted.

EN Shutdown

$I_{OUT}=0A$

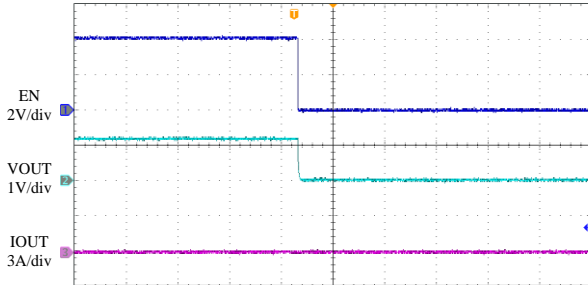

20ms/div

EN Shutdown

$I_{OUT}=3A$

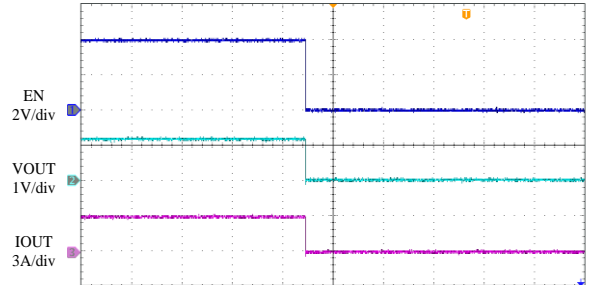

20ms/div

SCP Entry

$I_{OUT}=0A$

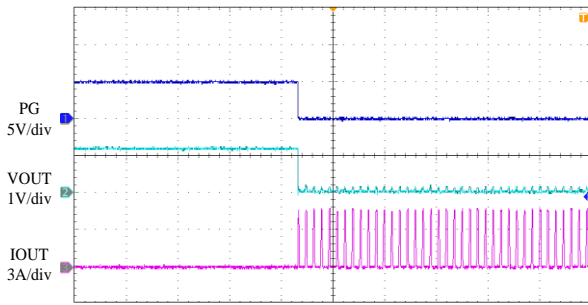

10ms/div

SCP Entry

$I_{OUT}=3A$

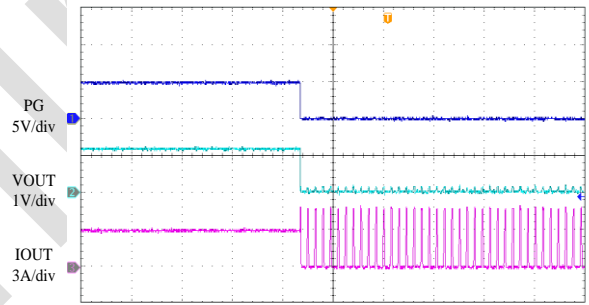

10ms/div

SCP Recovery

$I_{OUT}=0A$

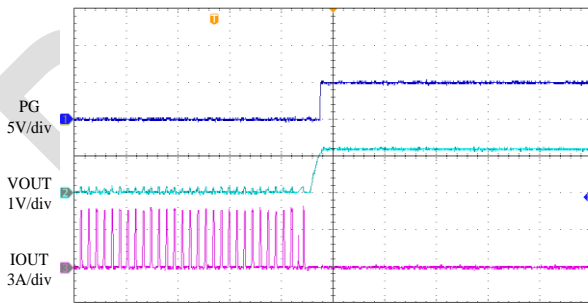

10ms/div

SCP Recovery

$I_{OUT}=3A$

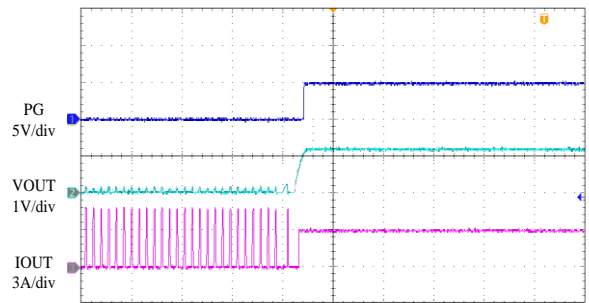

10ms/div



TYPICAL PERFORMANCE CHARACTERISTICS (continued)

$V_{IN}=5V$, $T_A=25^{\circ}C$, $F_{SW}=2.5MHz$, $V_{OUT}=1.2V$, unless otherwise noted.

VOUT Ripple

$I_{OUT}=0A$

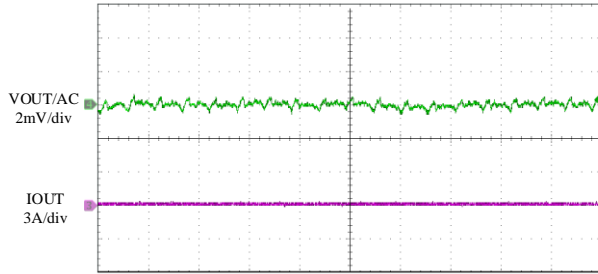

800ns/div

VOUT Ripple

$I_{OUT}=1A$

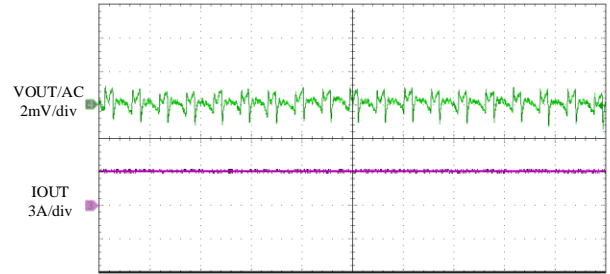

800ns/div

Load Transient

$I_{OUT}=0A$ to $0.5A$, $1A/\mu s$

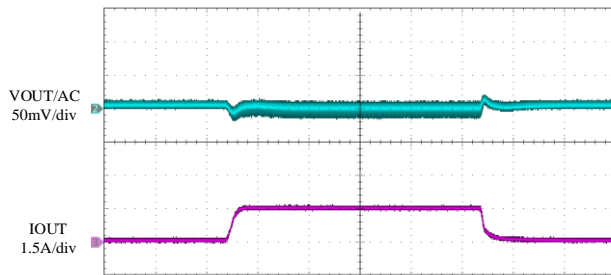

100μs/div

Load Transient

$I_{OUT}=0A$ to $3A$, $1A/\mu s$

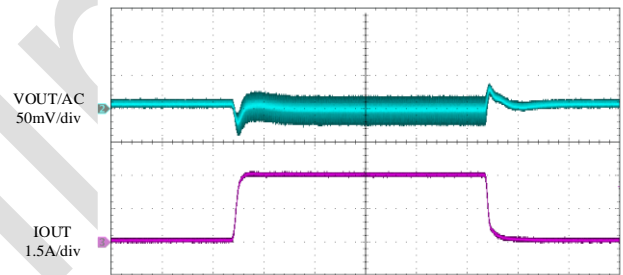

100μs/div

Load Transient

$I_{OUT}=1.5A$ to $3A$, $1A/\mu s$

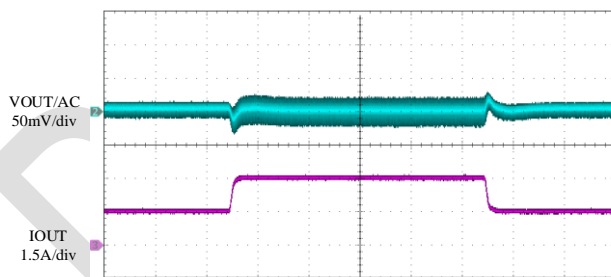

100μs/div



OPERATION

The M0503 is a 3A synchronous step-down switching mode Power SoC with integrated high-side and low-side power MosFETs, inductor and input decoupling capacitor in LGA-13 package. Only FB resistors, input and output capacitors are needed to complete the design over 2.5V to 6V input voltage range. The M0503 supports output voltage of 0.8V to 6V with the fixed switching frequency of 2.5MHz.

M0503 works on COT control mode that offers excellent transient response over the wide range of input voltage. M0503 operates in Forced Continuous Conduction Mode (FCCM) which keeps low output ripple. M0503 can work on 100% duty cycle when the dropout between input and output is low. The soft start time of M0503 is 2.5ms internally.

Fully integrated protection features include OCP, UVP, OTP and all these faults can be indicated by PG. The protection function details are shown below.

OVER CURRENT PROTECTION (OCP)

M0503 has a typical 5A cycle-by-cycle High-Side current limit protection to prevent inductor current from running away. When the High-Side switch reaches the current limit, M0503 will enter hiccup mode. It will stop switching for a pre-determined period of time and automatically start up again. It always starts up with soft-start to limit inrush current and avoid output overshoot.

OVER TEMPERATURE PROTECTION (OTP)

M0503 will stop switching when the junction temperature exceeds 160 °C. The device will power up again when the junction temperature drops below 130°C.



USER GUIDE

Output Voltage

The output voltage is set by the external feedback resistor divider as the typical application circuit on Page 1. The bottom feedback resistor R_2 can impact the loop stability. For any chosen R_2 , the top feedback resistor R_1 can be calculated as:

$$R_1 = R_2 \cdot \left(\frac{V_{OUT}}{V_{FB}} - 1 \right)$$

Table 1 lists the recommended feedback resistor values for common output voltages.

Table 1: FB Resistor Values for Common Output Voltages.

V _{OUT} (V)	R ₁ (kΩ)	R ₂ (kΩ)
3.3	100	31.6
1.8	37.4	30
1.2	15	30
1.0	7.5	30

Input Capacitor Selection

The input current of the step-down converter is discontinuous with sharp edges, therefore, placing input filter capacitors is necessary. For better performance, low ESR ceramic capacitor with X5R or X7R dielectrics are highly recommended because of their lowest temperature variations. The RMS current of the input capacitor is calculated:

$$I_{CIN_RMS} = I_{OUT} \sqrt{D(1-D)}$$

in which D is the Duty Cycle and when the current is continuous, $D = V_{OUT}/V_{IN}$; I_{OUT} is the output load current. As the equation above, when D is 0.5, the highest RMS current is approximately:

$$I_{CIN_RMS} = \frac{1}{2} \times I_{OUT}$$

So, it is recommended to choose the capacitors with the RMS current rating higher than $1/2 I_{OUT}$.

The power dissipation on the input capacitors can be estimated with the RMS current and the ESR.

Electrolytic or tantalum capacitors can also be used. The input voltage ripple caused by the capacitor can be calculated as:

$$\Delta V_{CIN} = \frac{I_{OUT}}{F_{SW} \cdot C_{IN}} \cdot \frac{V_{OUT}}{V_{IN}} \cdot \left(1 - \frac{V_{OUT}}{V_{IN}} \right)$$

in which, F_{SW} is switching frequency of 2.5MHz.

Output Capacitor Selection

Output capacitors are required to keep output voltage stable. To minimize the output voltage ripple, low ESR ceramic capacitors should be used. The output voltage ripple can be estimated as:

$$\Delta V_{OUT} = \frac{V_{OUT}}{8F_{SW}^2 C_{OUT} L} \cdot \left(1 - \frac{V_{OUT}}{V_{IN}} \right)$$

In which, L is the inductor fixed at 0.47μH internally.

If electrolytic or tantalum capacitors are used, the ESR will dominate the output voltage ripple as:

$$\Delta V_{OUT} = R_{ESR} \cdot \frac{V_{OUT}}{F_{SW} L} \cdot \left(1 - \frac{V_{OUT}}{V_{IN}} \right)$$

Enable Control

When input voltage is above the under-voltage-lock-out threshold, M0503 can be enabled by pulling the EN pin to above 1.21V and will be disabled if the EN pin is below 1.1V. It is recommended to pull up to V_{IN} with the resistor about 100kΩ.

Power Good Indicator

M0503 has an open drain PG indicator. PG will be pulled up if output voltage is within ±10% of regulation, otherwise PG is pulled down by internal NMos. A pull-up resistor to V_{IN} or V_{OUT} is needed if used and it is recommended to choose the resistor about 100kΩ.

PCB Layout Guide

To optimize the electrical and thermal performance, some PCB layout guidelines should be considered as below:

1. Use wide trace for the high current paths and keep it as short as possible. It helps to minimize the PCB conduction loss and thermal stress.
2. Place the input decoupling capacitor close to V_{IN} and PGND.
3. Connect all feedback network to FB shortly.
4. Keep the FB network away from the SW.



6V Input, 3A Step Down DC-DC Power SoC with Integrated Inductor

5. The PGND should be connected to a strong ground plane for better heat dissipation and noise protection.

Figure 1 gives a good example of the recommended layout.

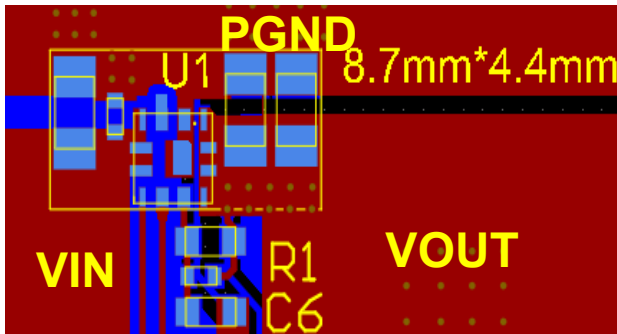

(a) Top Layer

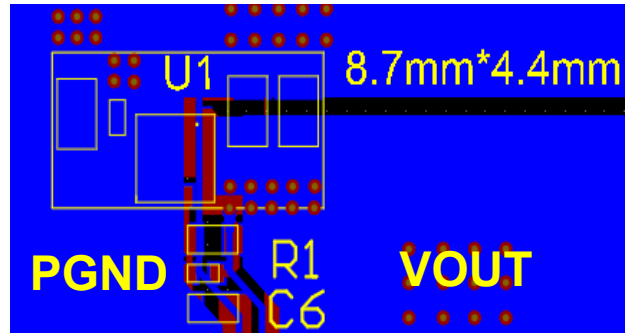

(b) Bottom Layer

Figure 1. Recommended Layout



TYPICAL APPLICATION

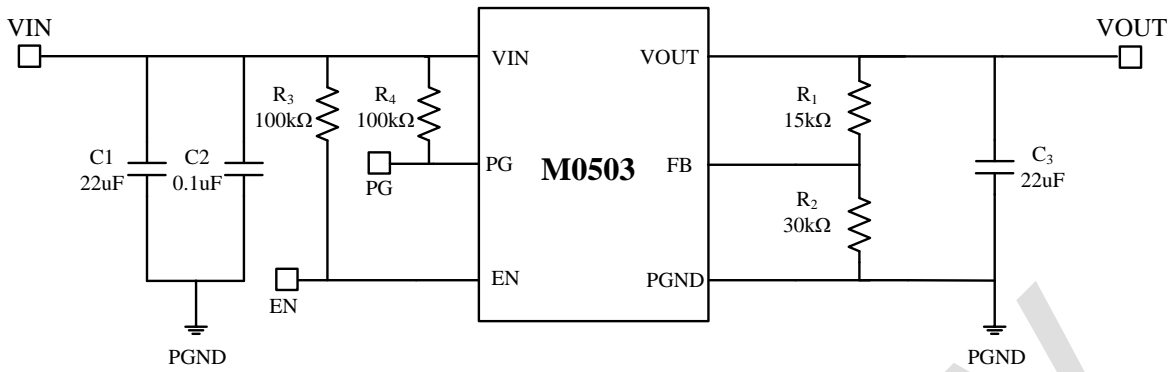

Figure 2. Typical Application Circuits of M0503 for 1.2V@3A Output

Table 2: Reference Design

VOUT(V)	CIN(uF)	COUT(uF)	R ₁ (kΩ)	R ₂ (kΩ)
3.3V	2×22	3×22	100	31.6
1.8V	22	3×22	37.4	30
1.2V	22	2×22	15	30
1.0V	22	2×22	7.5	30

NOTES:

CIN is the sum of the input capacitors, COUT is the sum of the output capacitors, please refer to Figure 2 for parameters of other components.



PACKAGE INFORMATION

LGA-13(2.5mm×2.5mm×1.24mm) Package

TOP VIEW

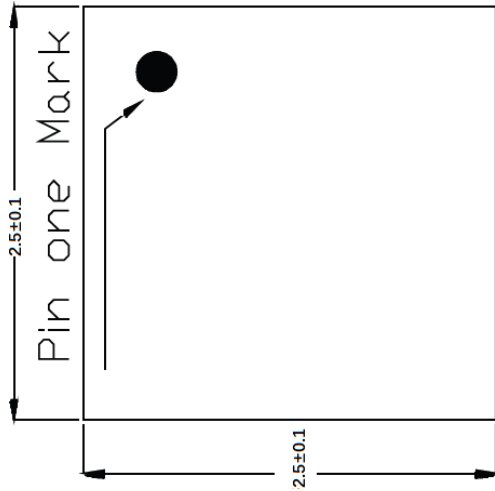

SIDE VIEW

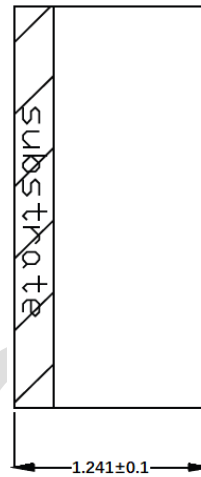

BOTTOM VIEW

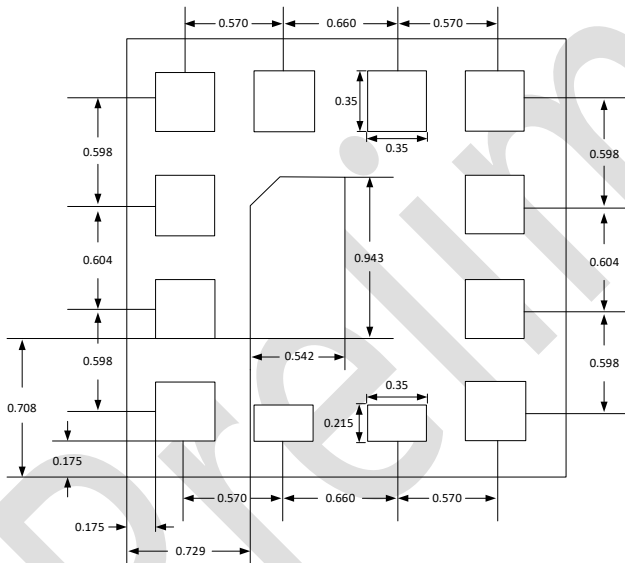

RECOMMENDED LAND PATTERN

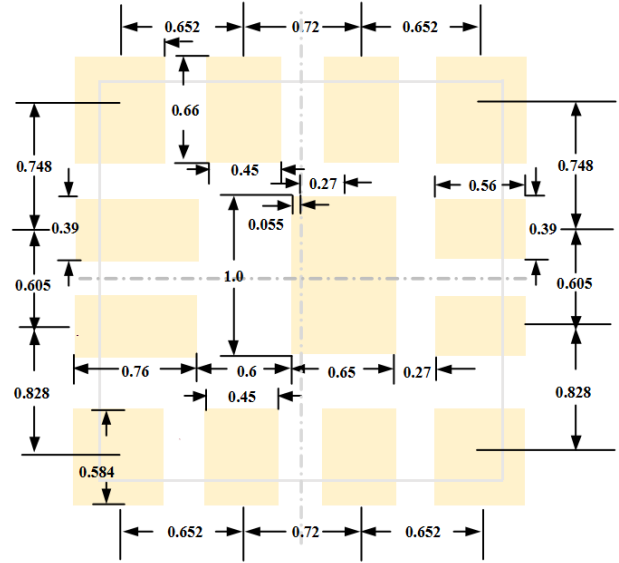

NOTES:

All dimensions are in MM.



PACKAGE INFORMATION

LGA-13(2.5mm×2.5mm×1.24mm) Package

(Not recommended for new design)

TOP VIEW

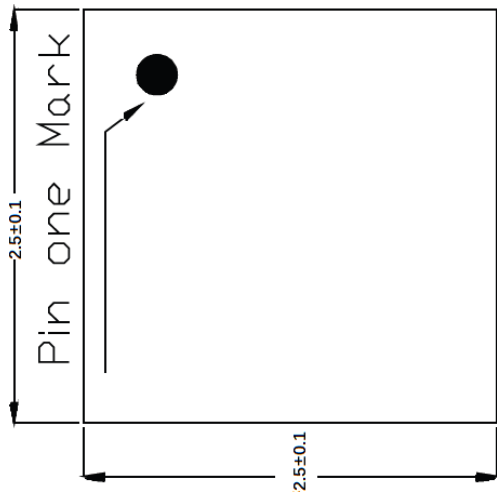

SIDE VIEW

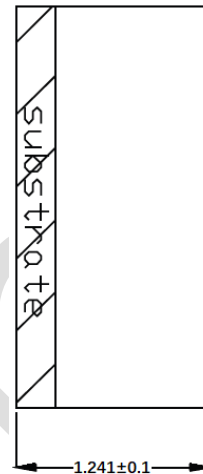

BOTTOM VIEW

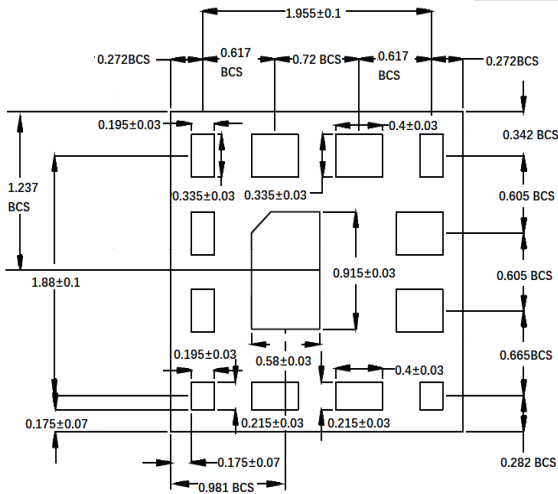

RECOMMENDED LAND PATTERN

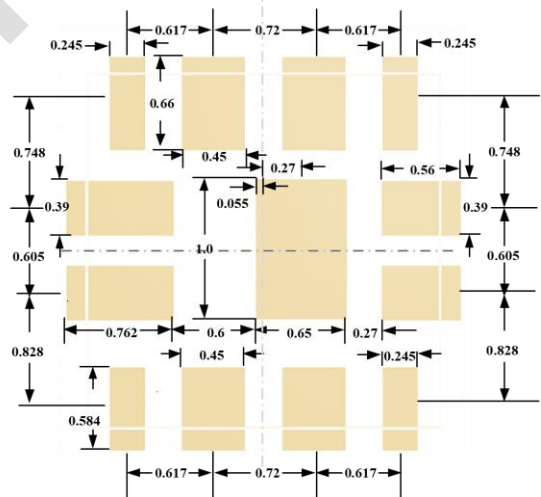

NOTES:

All dimensions are in MM.



CARRIER INFORMATION

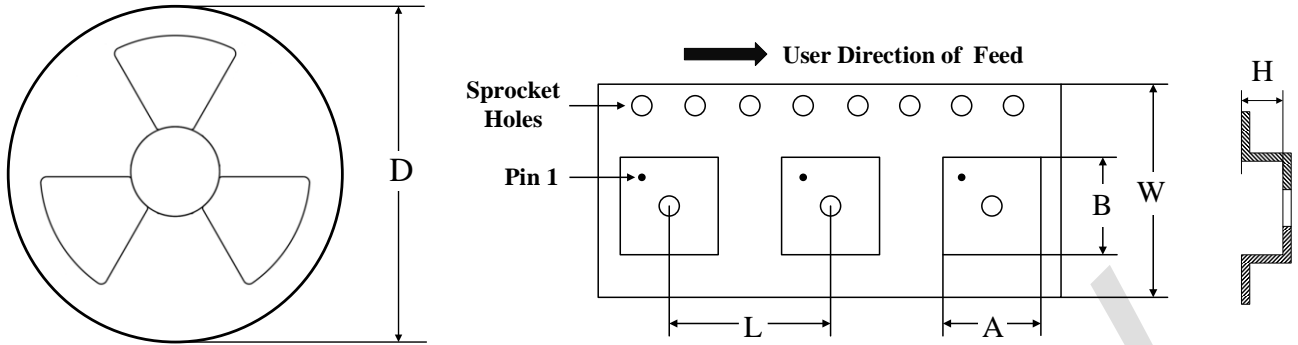

PART NUMBER	PACKAGE	QUANTITY /REEL	D	A	B	L	W	H
M0503DLBGP	LGA-13 (2.5mm×2.5mm×1.24mm)	3000	13 in	2.7mm	2.7mm	8mm	12mm	1.5mm
M0503DLBG	LGA-13 (2.5mm×2.5mm×1.24mm)	3000	13 in	2.7mm	2.7mm	8mm	12mm	1.5mm

单击下面可查看定价，库存，交付和生命周期等信息

[>>iModule\(沃芯\)](#)