

REV.	ECR/ECN No.	DESCRIPTION	DRAWN/DATE	CHECKED/DATE	APPROVED/DATE
A	ECN20200066	NEW RELEASE	Staven 2020-09-01	Staven 2020-09-01	Biao 2020-09-01

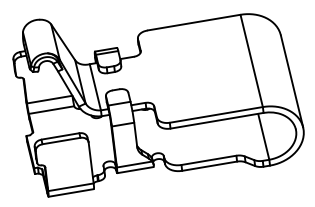
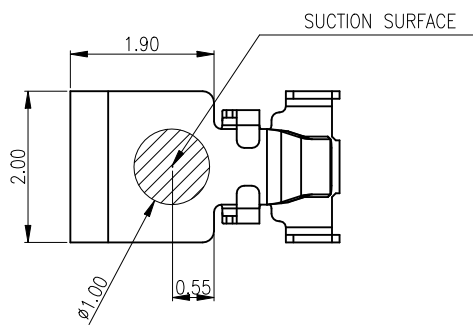

SPECIFICATIONS:

1. MATERIAL: COPPER ALLOY T=0.10mm
2. PLATING: GOLD FLASH SURFACE PLATING OVER CONTACT AREAS, GOLD FLASH SURFACE PLATING OVER SOLDER AREAS, Ni 40-120u" UNDER PLATING OVER ALL.
3. CURRENT: 3A MAX.
4. CONTACT RESISTANCE: 30mΩ MAX.

A

A

B

B

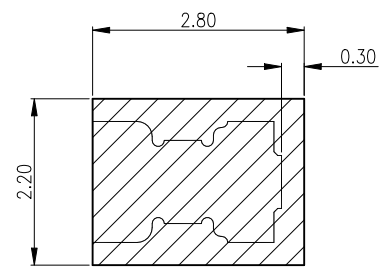
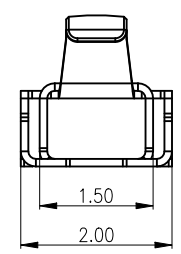
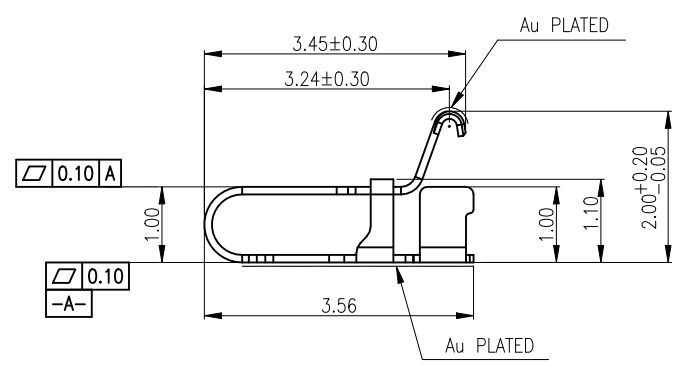

PCB LAYOUT RECOMMEND (TOP VIEW) TOLERANCE:±0.05

C

C

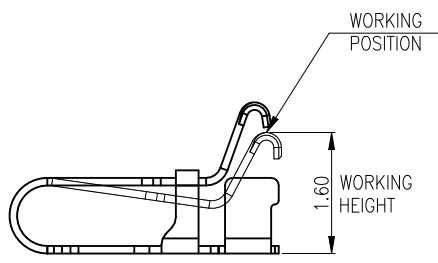
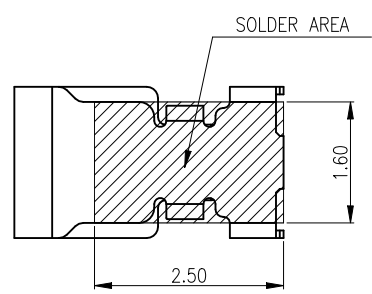

D

D

UNLESS OTHERWISE SPECIFIED TOLERANCES			ANGLE OF PROJECTION		 Amphenol Aorora Technology (Huizhou) Co.,Ltd
X.	±0.30	X. °			
X.X	±0.25	X.X °	Customer Drw		
X.XX	±0.20	X.XX °	DOC TYPE	DATE	TITLE: H2.0mm SPRING ESD
X.XXX	±0.15	X.XXX °	DRAWN	Staven 2020-09-01	
LINEAR DIMS		ANGLES DIMS		DESIGN	SIZE PART NUMBER: A4 Z02E-4F7L1-11000
DWG NO.: A-S0602				DATE	
MATERIAL	SEE NOTES			CHECKED	REV. A
FINISHED	SEE NOTES			DATE	SCALE 1:1 UNIT : mm SHEET 1 OF 1
				APPROVED	
				DATE	

This document is the property of and embodies CONFIDENTIAL and PROPRIETARY information of AOR. No part of the information shown on this document may be used in any way or disclosed to others without the written consent of AOR. © 2019 AOR

REV.	ECR/ECN No.	DESCRIPTION	DRAWN/DATE	CHECKED/DATE	APPROVED/DATE
A	ECN20200066	INITIAL RELEASE	Staven 2020-09-01	Staven 2020-09-01	Biao 2020-09-01
B	ECN2021015	UPDATE TAPE REEL	Staven 2021-03-13	Staven 2021-03-13	Biao 2020-03-13

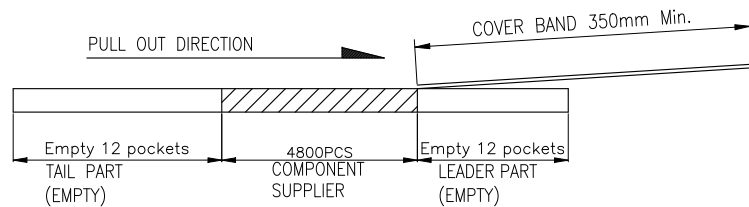
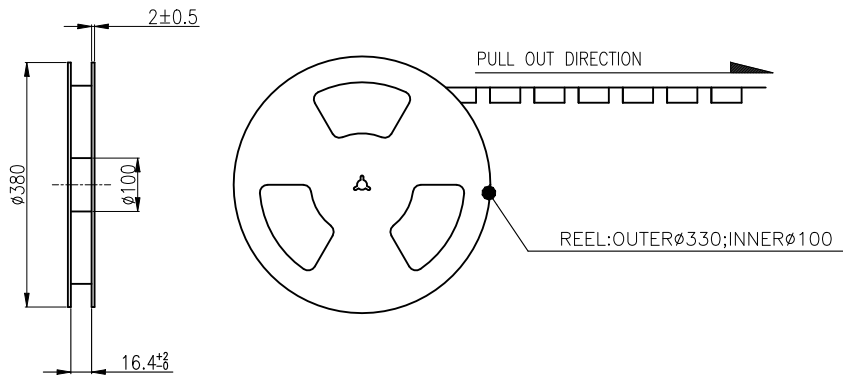
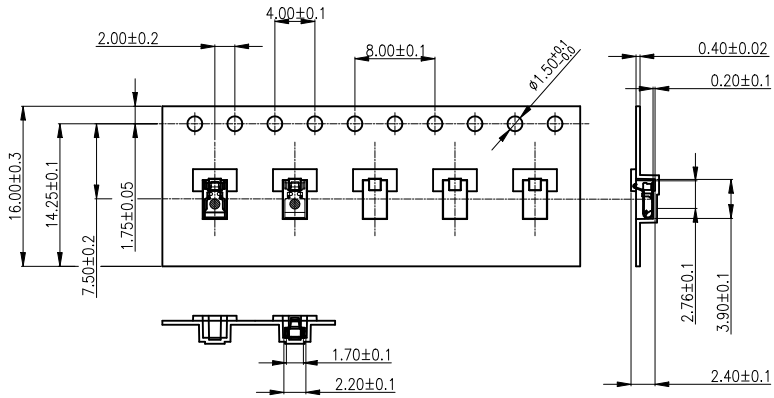

NOTES:

- MATERIAL:
 - CARRY TAPE:HIPS,T=0.40mm, COLOR:TRANSPARENT.
 - REEL:HIPS,BLUE.
 - SHIM:PET,CLEAR.
 - Protective belt:PS,CLEAR.
- PRIMARY PACKING:4800PCS/REEL.
- SECONDARY PACKING:15 REELS/CARTON ("TOTAL"=15*4800/CARTON).
- PEELING RESISTANCE: 0.2N~1.2N(20~120gf);
PEELING ANGLE: 165°~180°;
PEELING SPEED: 300mm/minutes.

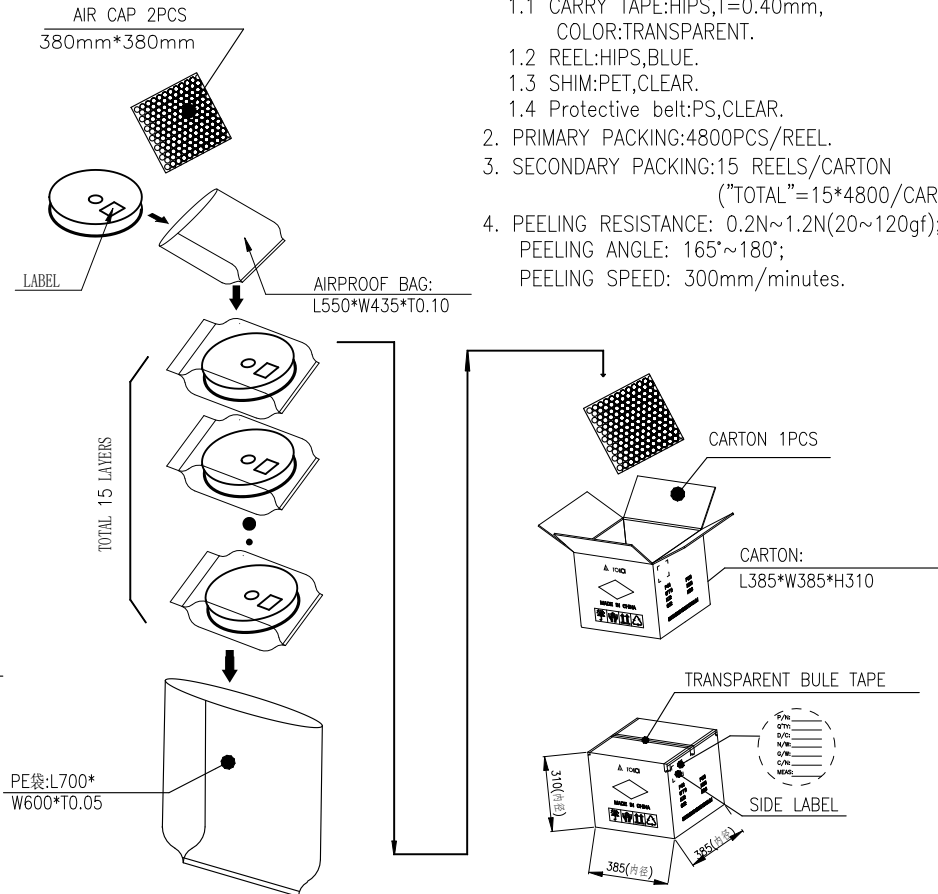

UNLESS OTHERWISE SPECIFIED TOLERANCES				ANGLE OF PROJECTION		Amphenol AORORA	
X.	±0.38	X. °	± 3'			Amphenol Aorora Technology (Huizhou) Co.,Ltd	
X.X	±0.36	X.X °	± 2'				
X.XX	±0.25	X.XX °	± 1'	DOC TYPE: Packing Drw		TITLE: SPRING H2.0-Packing	
X.XXX	±0.15	X.XXX °	± 1'	DRAWN DATE: Staven 2021-03-13			
LINEAR DIMS	ANGLES DIMS			DESIGN DATE: Staven 2021-03-13	SIZE: A4	PART NUMBER: 202E-4F7L1-11000	REV: B
DWG NO.: A-H0338	MATERIAL: SEE NOTES			CHECKED DATE: Biao 2021-03-13			
FINISHED	SEE NOTES			APPROVED DATE: Biao 2021-03-13	SCALE: 1:1	UNIT: mm	SHEET 1 OF 1

单击下面可查看定价，库存，交付和生命周期等信息

[>>Amphenol\(安费诺\)](#)