



RF360 Europe GmbH
A Qualcomm – TDK Joint Venture

Data sheet

SAW duplexer
LTE band 2

Series/type:	B1244
Ordering code:	B39202B1244P810
Date:	August 31, 2018
Version:	2.0

DCN: 80-PA243-221 Rev. A

RF360 products mentioned within this document are products of RF360 Europe GmbH and other subsidiaries of RF360 Holdings Singapore Pte. Ltd. (collectively, the "RF360 Subsidiaries").

RF360 Holdings Singapore Pte. Ltd. is a joint venture of Qualcomm Global Trading Pte. Ltd. and EPCOS AG.

RF360 Europe GmbH, Anzinger Str. 13, München, Germany

© 2018 RF360 Europe GmbH and/or its affiliated companies. All rights reserved.

These materials, including the information contained herein, may be used only for informational purposes by the customer. The RF360 Subsidiaries assume no responsibility for errors or omissions in these materials or the information contained herein. The RF360 Subsidiaries reserve the right to make changes to the product(s) or information contained herein without notice. The materials and information are provided on an AS IS basis, and the RF360 Subsidiaries assume no liability and make no warranty or representation, either expressed or implied, with respect to the materials, or any output or results based on the use, application, or evaluation of such materials, including, without limitation, with respect to the non-infringement of trademarks, patents, copyrights or any other intellectual property rights or other rights of third parties.

No use of this documentation or any information contained herein grants any license, whether express, implied, by estoppel or otherwise, to any intellectual property rights, including, without limitation, to any patents owned by QUALCOMM Incorporated or any of its subsidiaries.

Not to be used, copied, reproduced, or modified in whole or in part, nor its contents revealed in any manner to others without the express written permission of RF360 Europe GmbH.

Qualcomm is a trademark of Qualcomm Incorporated, registered in the United States and other countries. Other product and brand names may be trademarks or registered trademarks of their respective owners.

This technical data may be subject to U.S. and international export, re-export, or transfer ("export") laws. Diversion contrary to U.S. and international law is strictly prohibited.

Table of contents

1 Application	4
2 Features	4
3 Package	5
4 Pin configuration	5
5 Matching circuit	6
6 Characteristics	7
7 Maximum ratings	10
8 Transmission coefficients	11
9 Transmission coefficients (LTE)	14
10 Reflection coefficients	17
11 Packing material	18
12 Marking	22
13 Soldering profile	23
14 Annotations	24
15 Cautions and warnings	25
16 Important notes	26

1 Application

- Low-loss SAW duplexer for mobile telephone LTE Band 2 (PCS) systems.
- Low insertion attenuation
- Low amplitude ripple
- Usable pass band 60 MHz

2 Features

- Package size 1.8 ± 0.1 mm \times 1.4 ± 0.1 mm
- Package height 0.475 mm (max.)
- Approximate weight 3 mg
- RoHS compatible
- Package for Surface Mount Technology (SMT)
- Ni/Au-plated terminals
- Electrostatic Sensitive Device (ESD)
- Moisture Sensitivity Level 3 (MSL3)

3 Package

BOTTOM VIEW

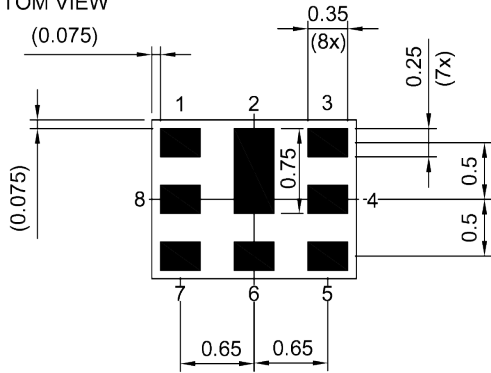

Pad and pitch tolerance ±0.05

SIDE VIEW

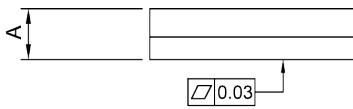

TOP VIEW

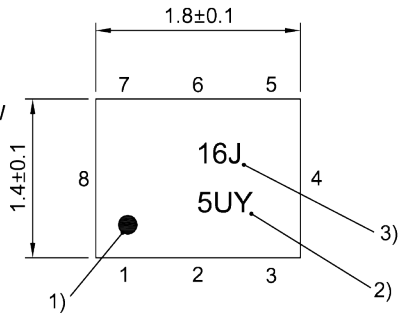

- 1) Marking for pad number 1
- 2) Example of encoded lot number
- 3) Example of encoded filter type number

Land pattern
THRU VIEW

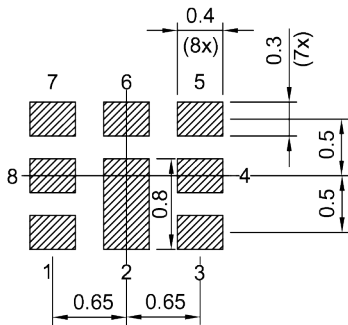

Landing pad tolerance -0.02

4 Pin configuration

- 1 RX
- 3 TX
- 6 ANT
- 2, 4, 5, 7, 8 Ground

Figure 1: Drawing of package with package height A = 0.475 mm (max.). See Sec. Package information (p. 25).

5 Matching circuit

■ $L_{p6} = 3.4 \text{ nH}$

■ $L_{s1} = 1.7 \text{ nH}$

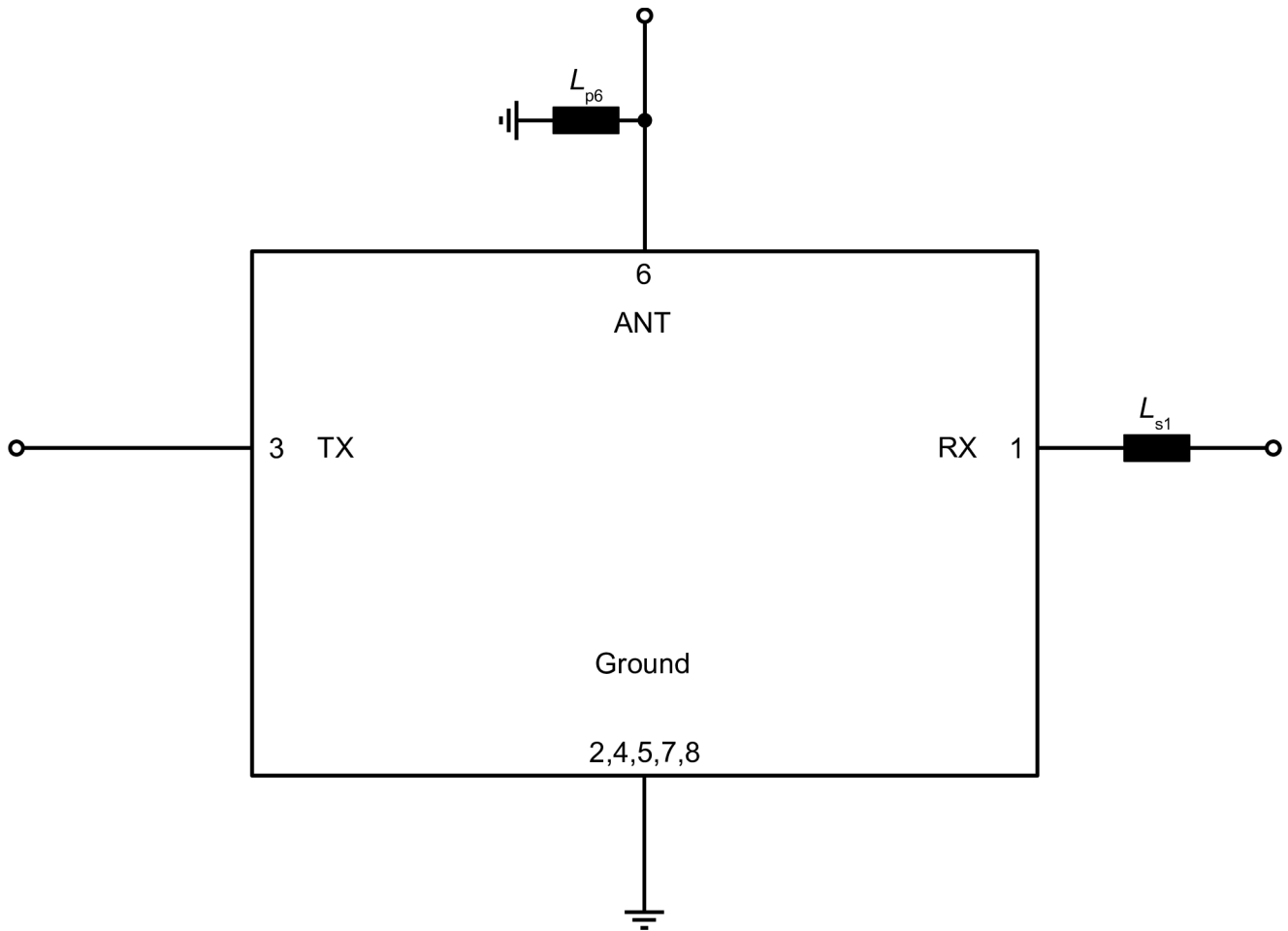

Figure 2: Schematic of matching circuit.

External shunt inductor for ESD protection is recommended at any ports towards antenna.

6 Characteristics

6.1 TX – ANT

Temperature range for specification	T_{SPEC}	= -30 °C ... +85 °C
TX terminating impedance	Z_{TX}	= 50 Ω
ANT terminating impedance	Z_{ANT}	= 50 Ω with par. 3.4 nH ¹⁾
RX terminating impedance	Z_{RX}	= 50 Ω with ser. 1.7 nH ¹⁾

Characteristics TX – ANT ²⁾				min. for T_{SPEC}	typ. @ +25 °C	max. for T_{SPEC}	
Center frequency			f_C	—	1880	—	MHz
Maximum insertion attenuation	1850... 1910	MHz	$\alpha_{INT,max}^{3)}$	—	1.5	2.4	dB
	1850.24... 1909.76	MHz	α_{max}	—	1.7	2.4	dB
Maximum VSWR			VSWR _{max}				
@ TX port	1850.24... 1909.76	MHz		—	1.6	2.0	
@ ANT port	1850.24... 1909.76	MHz		—	1.5	2.0	
Minimum attenuation			α_{min}				
	10... 894	MHz		44	46	—	dB
	1226... 1250	MHz		40	42	—	dB
	1559... 1605.9	MHz		42	44	—	dB
	1605.8... 1680	MHz		40	47	—	dB
	1930.24... 1989.76	MHz		45	55	—	dB
	2010... 2025	MHz		40	50	—	dB
	2110... 2155	MHz		40	44	—	dB
	2400... 2500	MHz		25	35	—	dB
	3700... 3820	MHz		28	33	—	dB
	4900... 5850	MHz		19	23	—	dB
	5254... 5455	MHz		22	25	—	dB
	5540... 5950	MHz		17	22	—	dB

¹⁾ See Sec. Matching circuit (p. 6).

²⁾ Specified min/max values are valid for a testing power of +10 dBm.

³⁾ Integrated attenuation α_{INT} : Averaged power $|S_{ij}|^2$ over the center 4.5 MHz of LTE 5 MHz (25 RB) channels.

6.2 ANT – RX

Temperature range for specification	T_{SPEC}	= -30 °C ... +85 °C
TX terminating impedance	Z_{TX}	= 50 Ω
ANT terminating impedance	Z_{ANT}	= 50 Ω with par. 3.4 nH ¹⁾
RX terminating impedance	Z_{RX}	= 50 Ω with ser. 1.7 nH ¹⁾

Characteristics ANT – RX ²⁾				min. for T_{SPEC}	typ. @ +25 °C	max. for T_{SPEC}	
Center frequency			f_C	—	1960	—	MHz
Maximum insertion attenuation							
	1930... 1990	MHz	$\alpha_{INT,max}$ ³⁾	—	2.2	3.0	dB
	1930.24... 1989.76	MHz	α_{max}	—	2.4	3.0 ⁴⁾	dB
	1930.24... 1989.76	MHz	α_{max}	—	2.4	3.2 ⁵⁾	dB
Maximum VSWR			VSWR _{max}				
@ ANT port	1930.24... 1989.76	MHz		—	1.6	2.0	
@ RX port	1930.24... 1989.76	MHz		—	1.5	2.0	
Minimum attenuation			α_{min}				
	10... 1100	MHz		45	49	—	dB
	80	MHz		50	70	—	dB
	1100... 1850	MHz		41	45	—	dB
	1850.24... 1909.76	MHz		45	50	—	dB
	2050... 2075	MHz		35	42	—	dB
	2075... 2305	MHz		30	34	—	dB
	2305... 2315	MHz		40	50	—	dB
	2315... 2550	MHz		15	20	—	dB
	2550... 6000	MHz		40	45	—	dB

- ¹⁾ See Sec. Matching circuit (p. 6).
²⁾ Specified min/max values are valid for a testing power of +10 dBm.
³⁾ Integrated attenuation α_{INT} : Averaged power $|S_{ij}|^2$ over the center 4.5 MHz of LTE 5 MHz (25 RB) channels.
⁴⁾ Valid for temperature $T = +25\text{ °C} \dots +85\text{ °C}$.
⁵⁾ Valid for temperature $T = -30\text{ °C} \dots +25\text{ °C}$.

6.3 TX – RX

Temperature range for specification	T_{SPEC}	= -30 °C ... +85 °C
TX terminating impedance	Z_{TX}	= 50 Ω
ANT terminating impedance	Z_{ANT}	= 50 Ω with par. 3.4 nH ¹⁾
RX terminating impedance	Z_{RX}	= 50 Ω with ser. 1.7 nH ¹⁾

Characteristics TX – RX ²⁾				min. for T_{SPEC}	typ. @ +25 °C	max. for T_{SPEC}	
Minimum isolation							
	1574... 1577	MHz	α_{min}	55	63	—	dB
	1850... 1910	MHz	$\alpha_{INT,min}^{3)}$	54	56	—	dB
	1850.24... 1909.76	MHz	α_{min}	53 ⁴⁾	56	—	dB
	1850.24... 1909.76	MHz	α_{min}	51	56	—	dB
	1930... 1990	MHz	$\alpha_{INT,min}^{3)}$	55	60	—	dB
	1930.24... 1989.76	MHz	α_{min}	55 ⁵⁾	60	—	dB
	1930.24... 1989.76	MHz	α_{min}	50	60	—	dB
	3700... 3820	MHz	α_{min}	45	52	—	dB
	5550... 5850	MHz	α_{min}	42	50	—	dB

- ¹⁾ See Sec. Matching circuit (p. 6).
- ²⁾ Specified min/max values are valid for a testing power of +10 dBm.
- ³⁾ Integrated attenuation α_{INT} : Averaged power $|S_{ij}|^2$ over the center 4.5 MHz of LTE 5 MHz (25 RB) channels.
- ⁴⁾ Valid for temperature $T = -30\text{ °C} \dots +25\text{ °C}$.
- ⁵⁾ Valid for temperature $T = +25\text{ °C} \dots +85\text{ °C}$.

7 Maximum ratings

Storage temperature	$T_{STG}^{1)} = -40\text{ °C} \dots +90\text{ °C}$	
DC voltage	$ V_{DC} ^{3)} = 0\text{ V (max.)}^{2)}$	
ESD voltage		
	$V_{ESD}^{4)} = 50\text{ V (max.)}$	Machine model.
	$V_{ESD}^{5)} = 300\text{ V (max.)}$	Human body model.
	$V_{ESD}^{6)} = 600\text{ V (max.)}$	Charged device model.
Input power @ TX port: 1850.24 ... 1909.76 MHz	$P_{IN} = 30\text{ dBm}$	Continuous wave for 5000 h @ 50 °C.

¹⁾ Not valid for packaging material. Storage temperature for packaging material is -25 °C to +40 °C.

²⁾ 168h Damp Heat Steady State acc. IEC 60068-2-67 Cy.

³⁾ In case of applied DC voltage blocking capacitors are mandatory.

⁴⁾ According to JESD22-A115B (MM – Machine Model), 10 negative & 10 positive pulses.

⁵⁾ According to JESD22-A114F (HBM – Human Body Model), 1 negative & 1 positive pulse.

⁶⁾ According to JESD22-C101C (CDM – Field Induced Charged Device Model), 3 negative & 3 positive pulses.

8 Transmission coefficients

8.1 TX – ANT

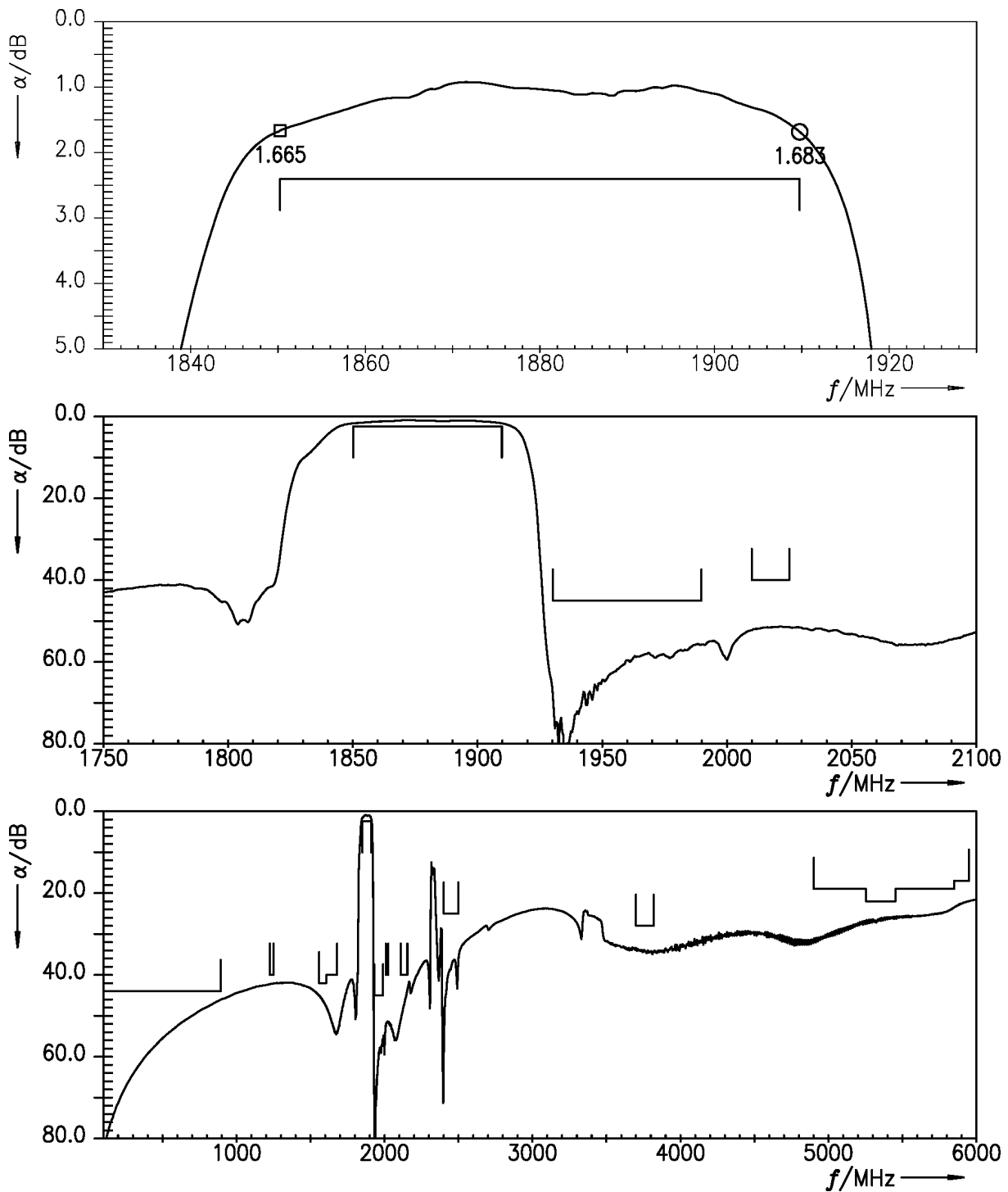

Figure 3: Attenuation TX – ANT.

8.2 ANT – RX

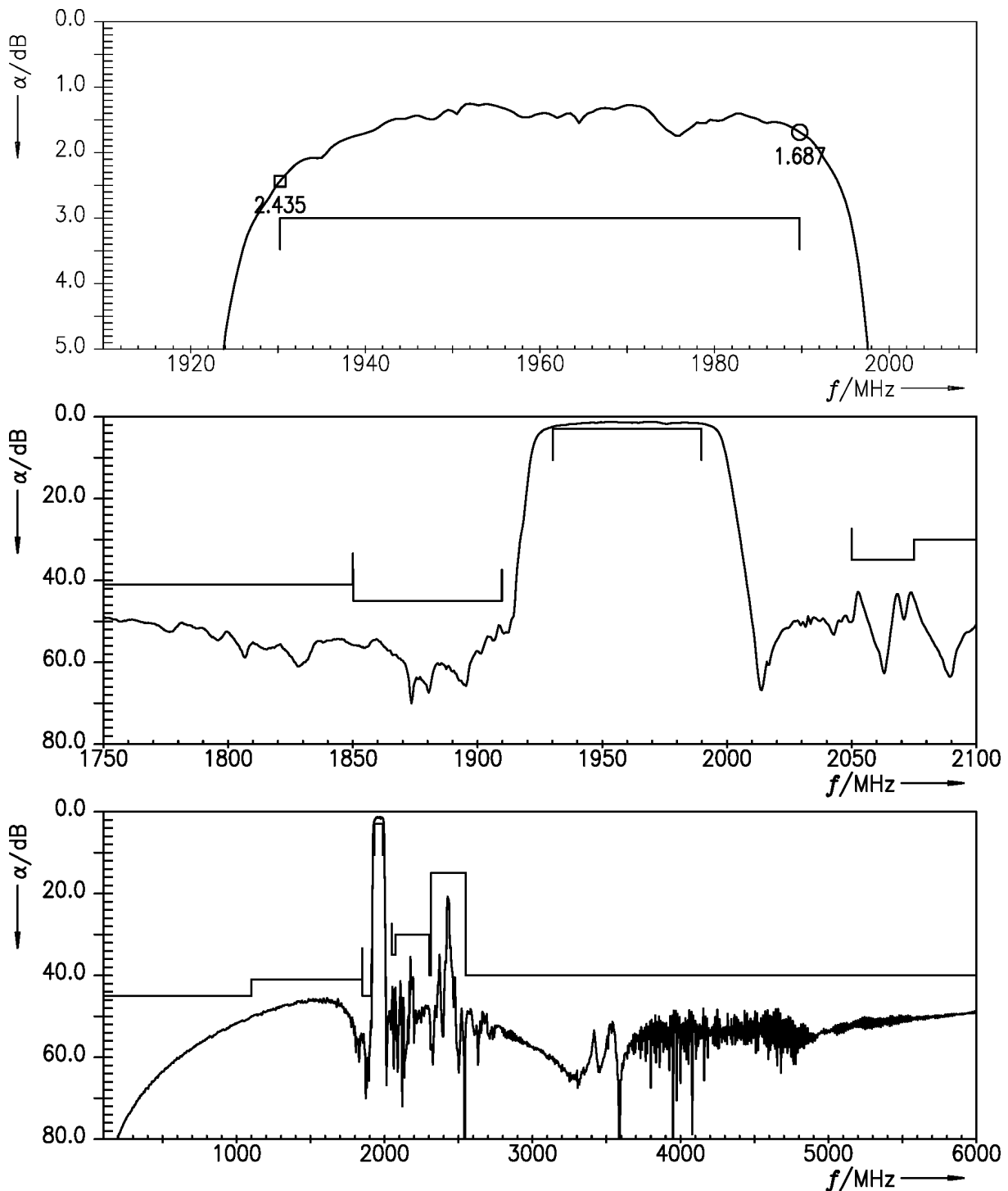

Figure 4: Attenuation ANT – RX.

8.3 TX – RX

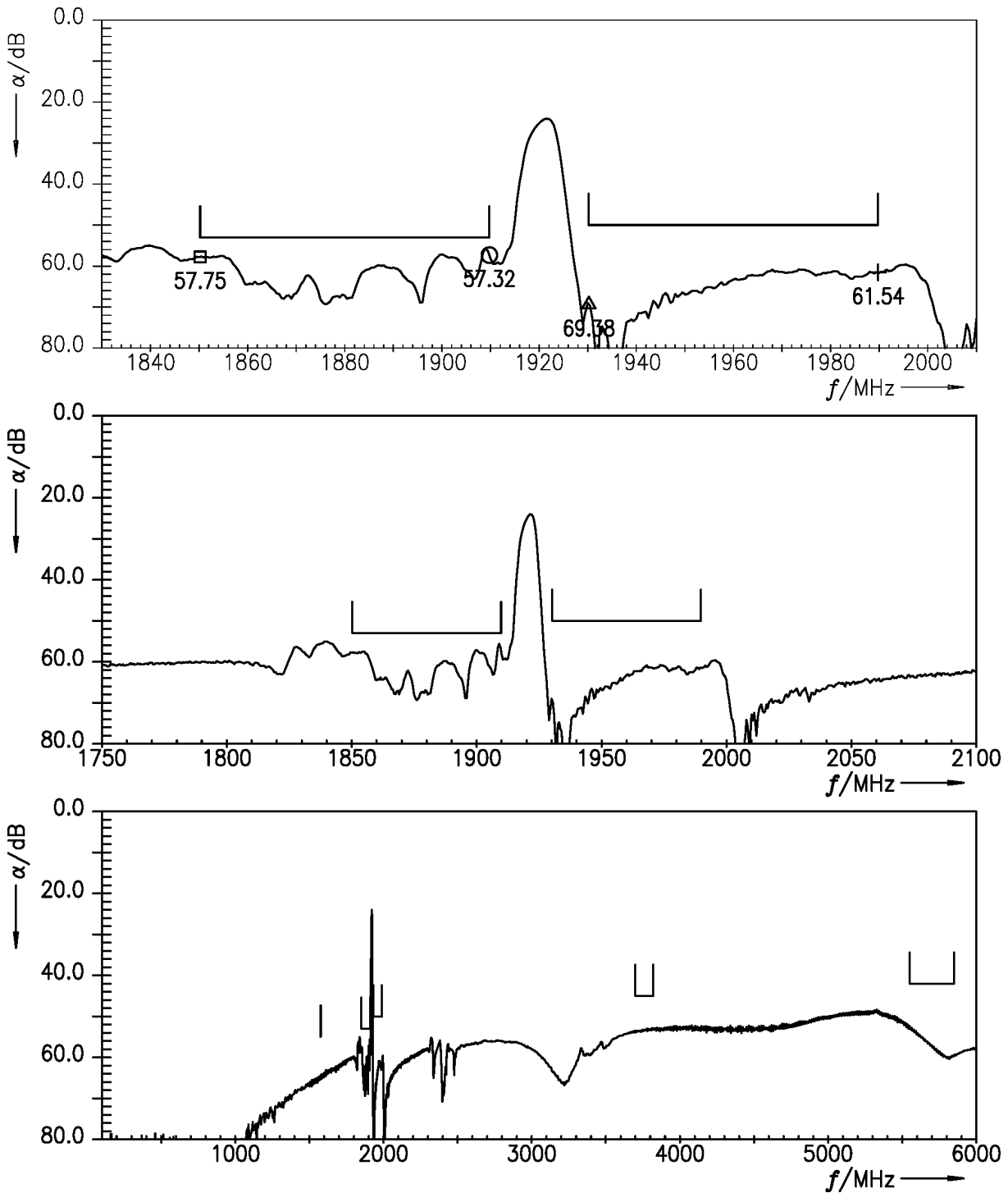

Figure 5: Isolation TX – RX.

9 Transmission coefficients (LTE)

9.1 TX – ANT

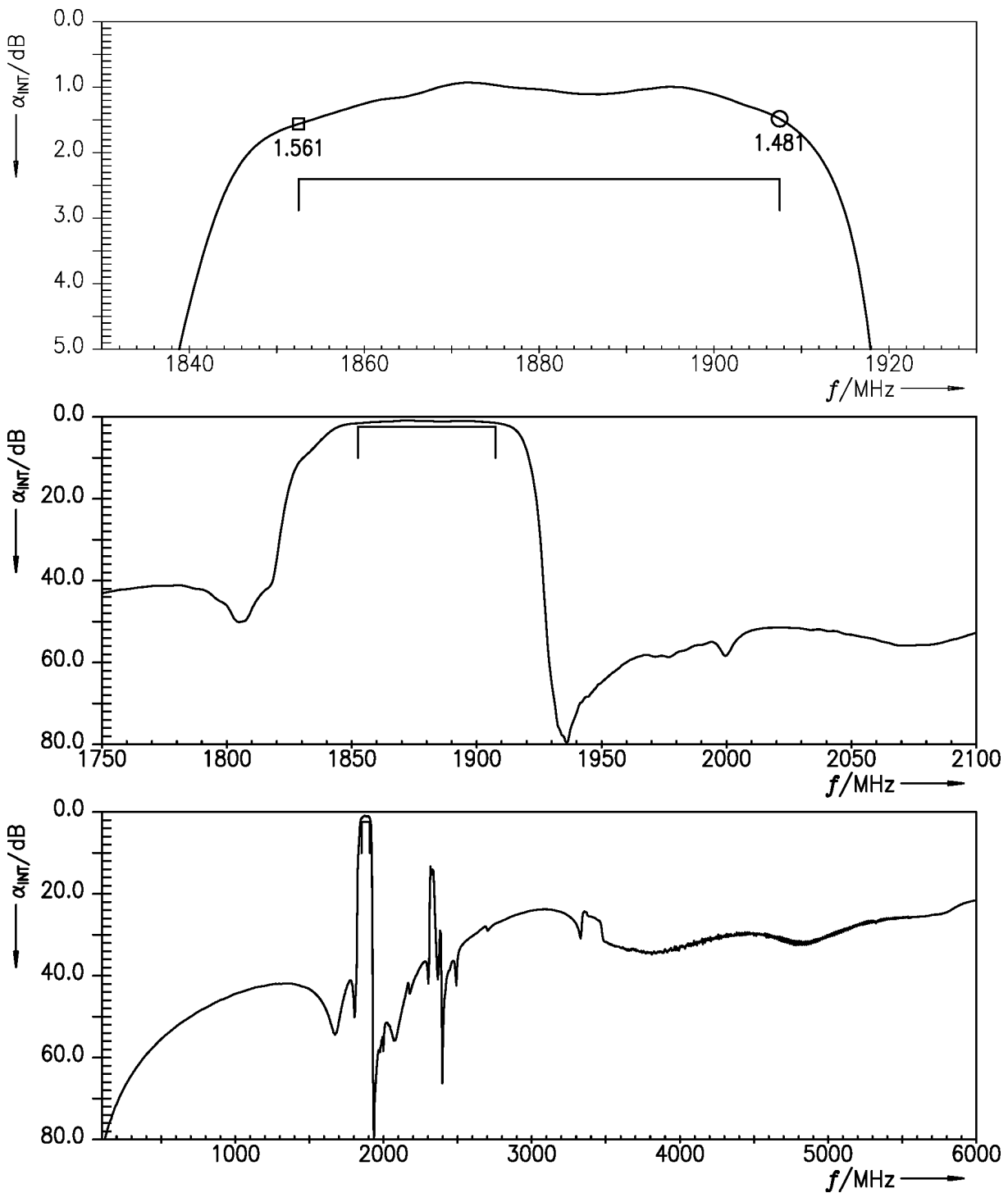

Figure 6: Attenuation (LTE) (integration window = 5 MHz) TX – ANT.

9.2 ANT – RX

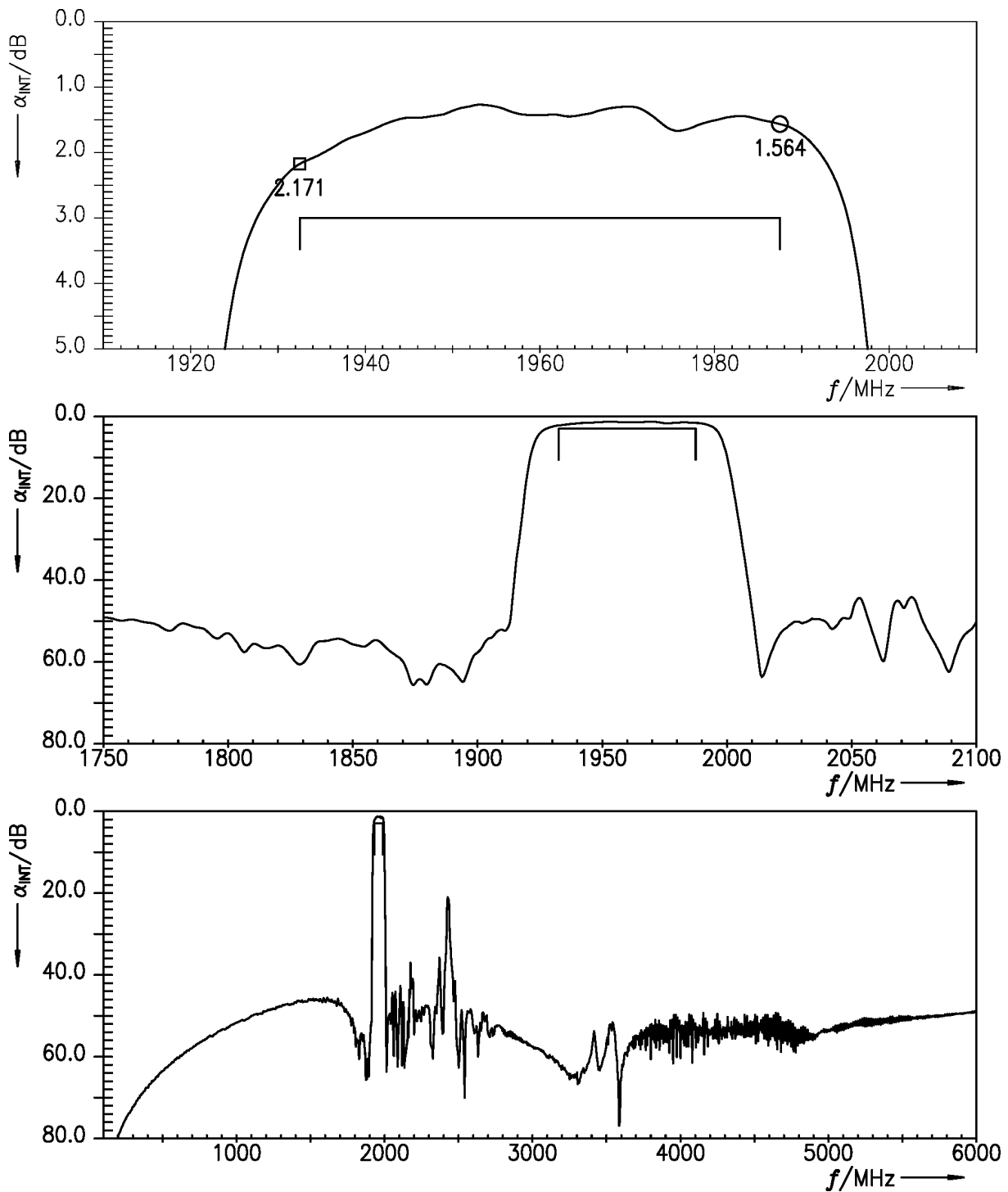

Figure 7: Attenuation (LTE) (integration window = 5 MHz) ANT – RX.

9.3 TX – RX

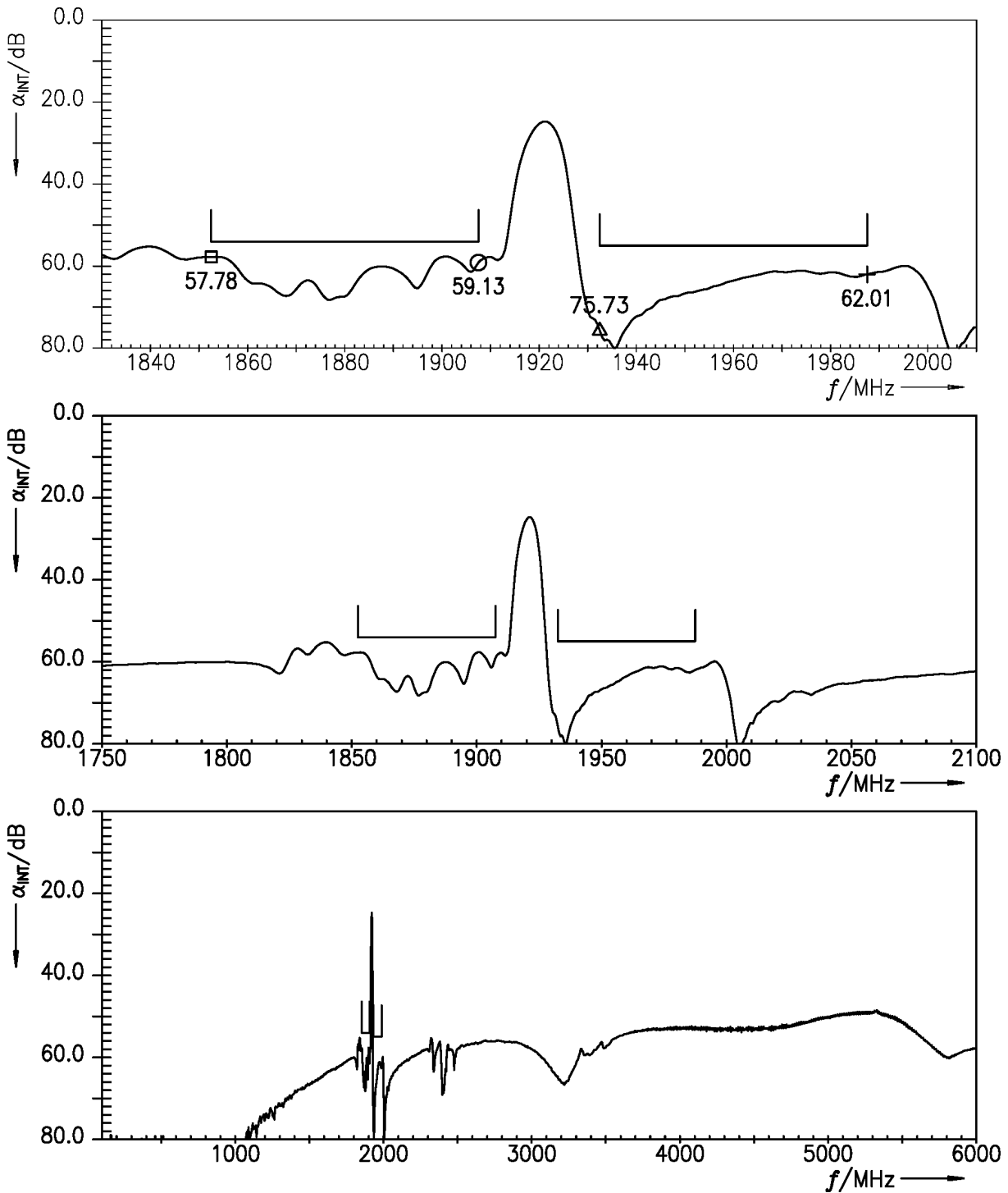

Figure 8: Isolation (LTE) (integration window = 5 MHz) TX – RX.

10 Reflection coefficients

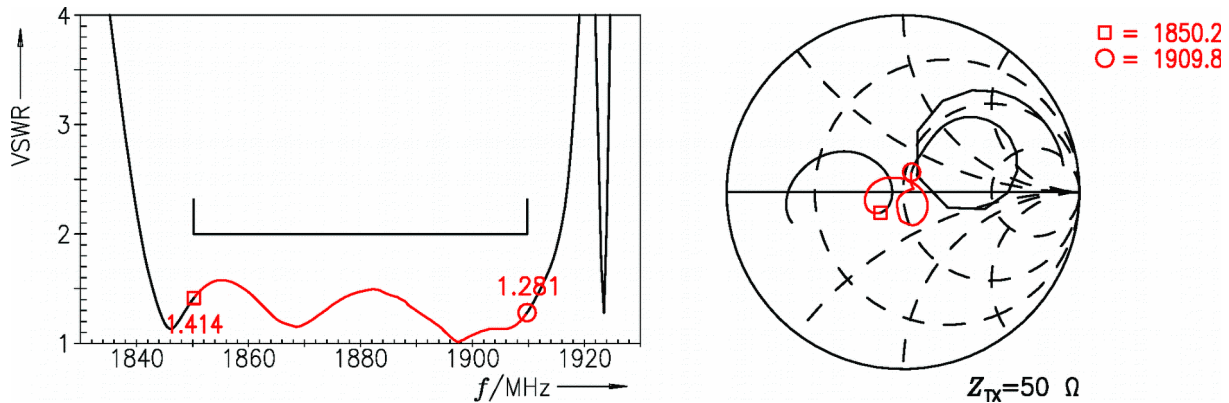

Figure 9: Reflection coefficient at TX port.

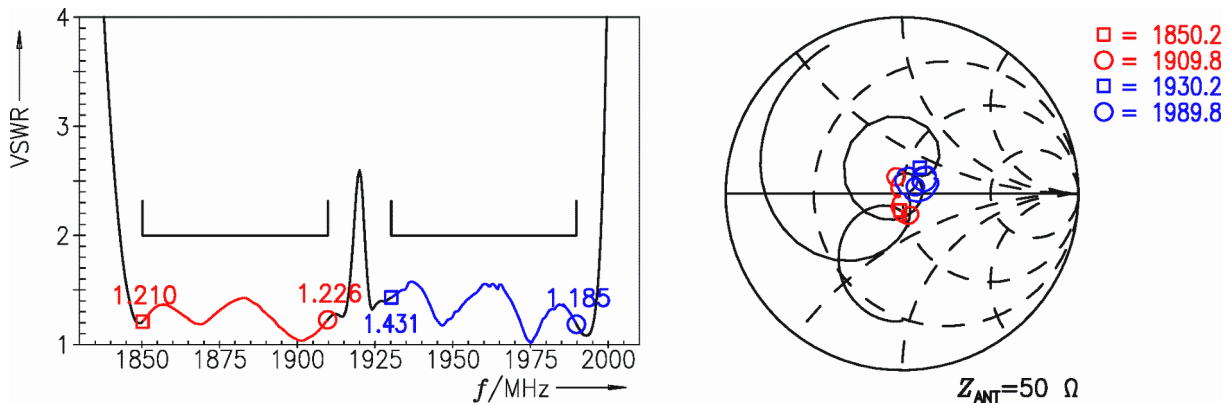

Figure 10: Reflection coefficient at ANT port.

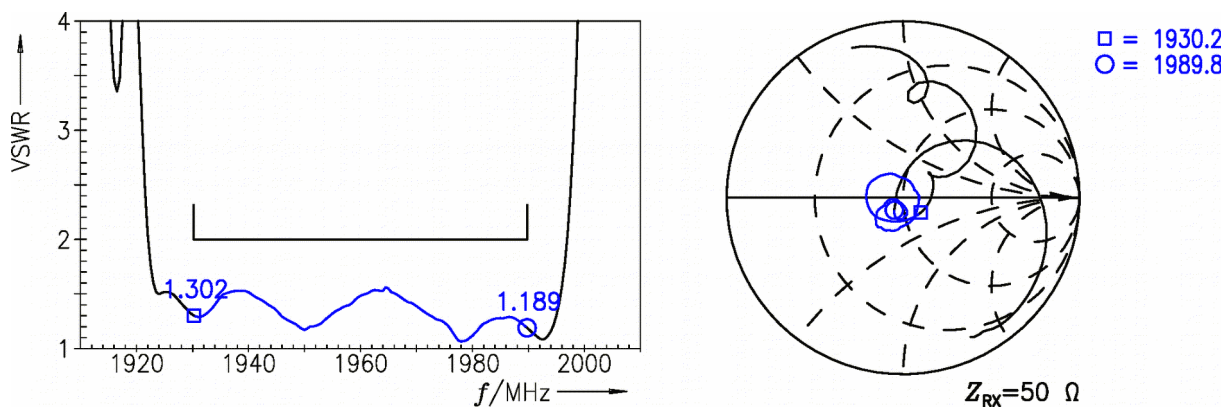
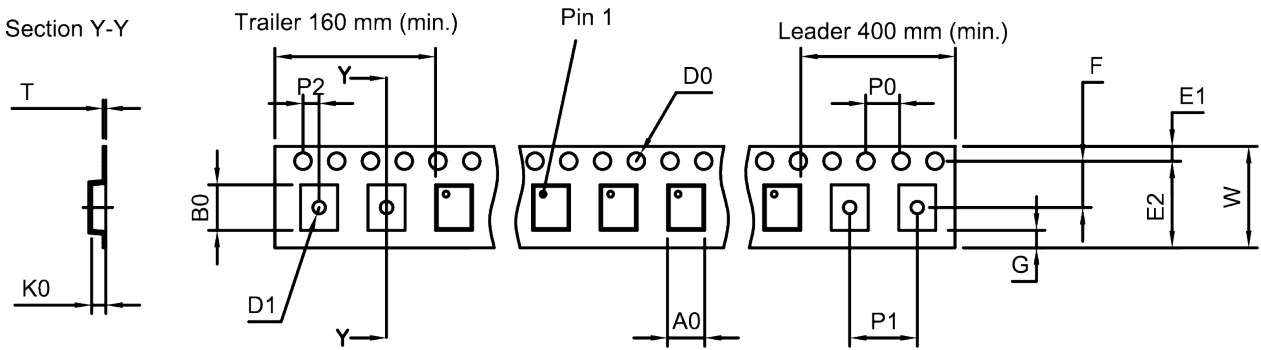

Figure 11: Reflection coefficient at RX port.



11 Packing material

11.1 Tape



User direction of unreeling

Figure 12: Drawing of tape (first-angle projection) with tape dimensions according to Table 1.

A_0	1.62 ± 0.05 mm	E_2	6.25 mm (min.)	P_1	4.0 ± 0.1 mm
B_0	2.04 ± 0.05 mm	F	3.5 ± 0.05 mm	P_2	2.0 ± 0.05 mm
D_0	$1.5^{+0.1/-0}$ mm	G	0.75 mm (min.)	T	0.25 ± 0.05 mm
D_1	0.8 ± 0.05 mm	K_0	0.62 ± 0.05 mm	W	8.0 ± 0.1 mm
E_1	1.75 ± 0.1 mm	P_0	4.0 ± 0.1 mm		

Table 1: Tape dimensions.

11.2 Reel with diameter of 180 mm

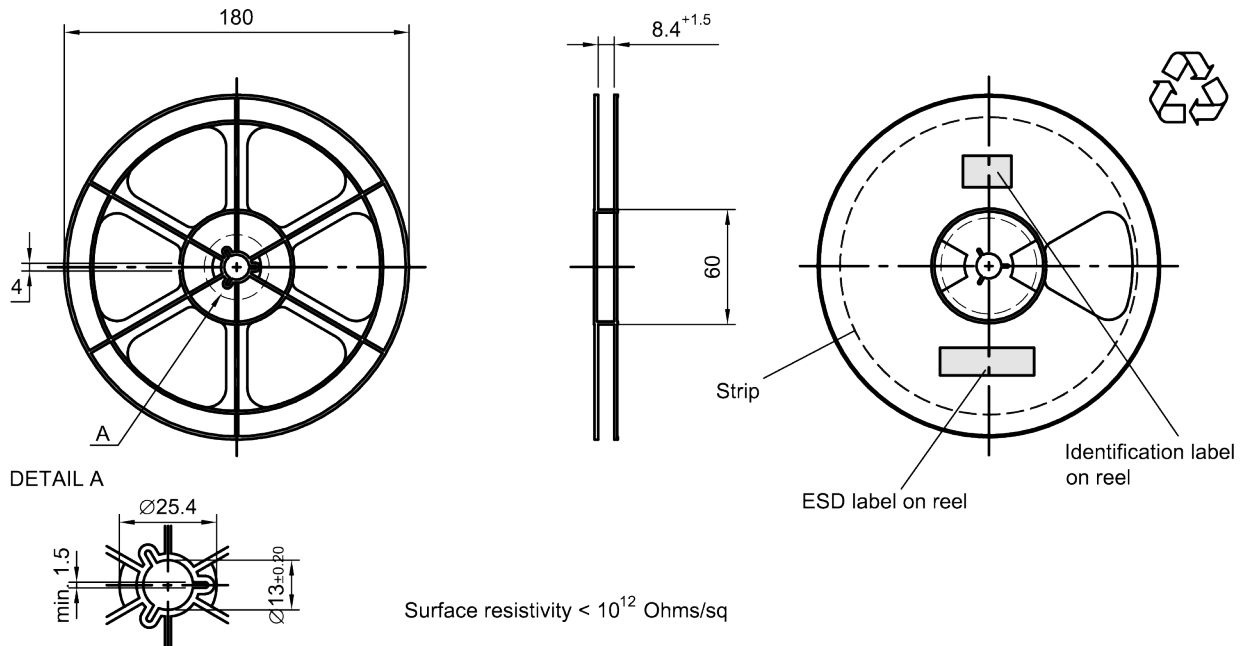

Figure 13: Drawing of reel (first-angle projection) with diameter of 180 mm.

Dimensions [mm]

X = 220+5

Y = 235+5

Sealing area 10±3

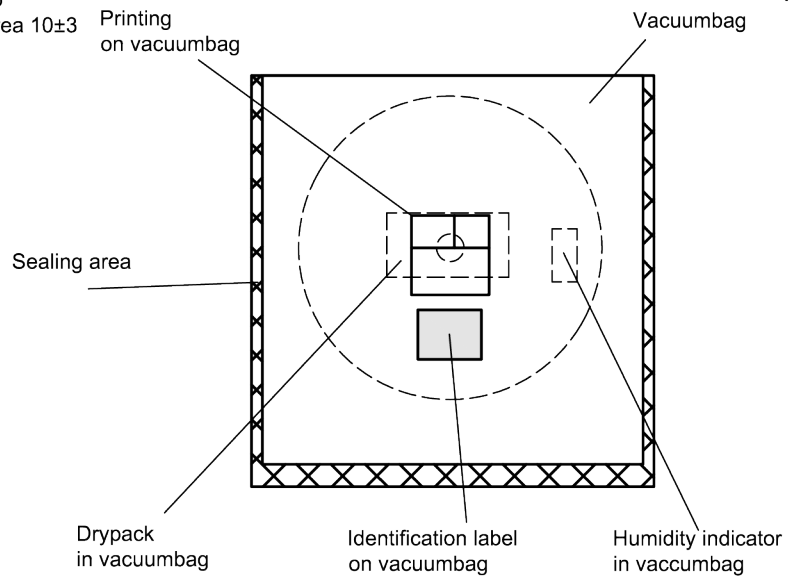

Figure 14: Drawing of moisture barrier bag (MBB) for reel with diameter of 180 mm.

Dimensions [mm]
L = 188
B = 188
H = 30
Tolerance ±5

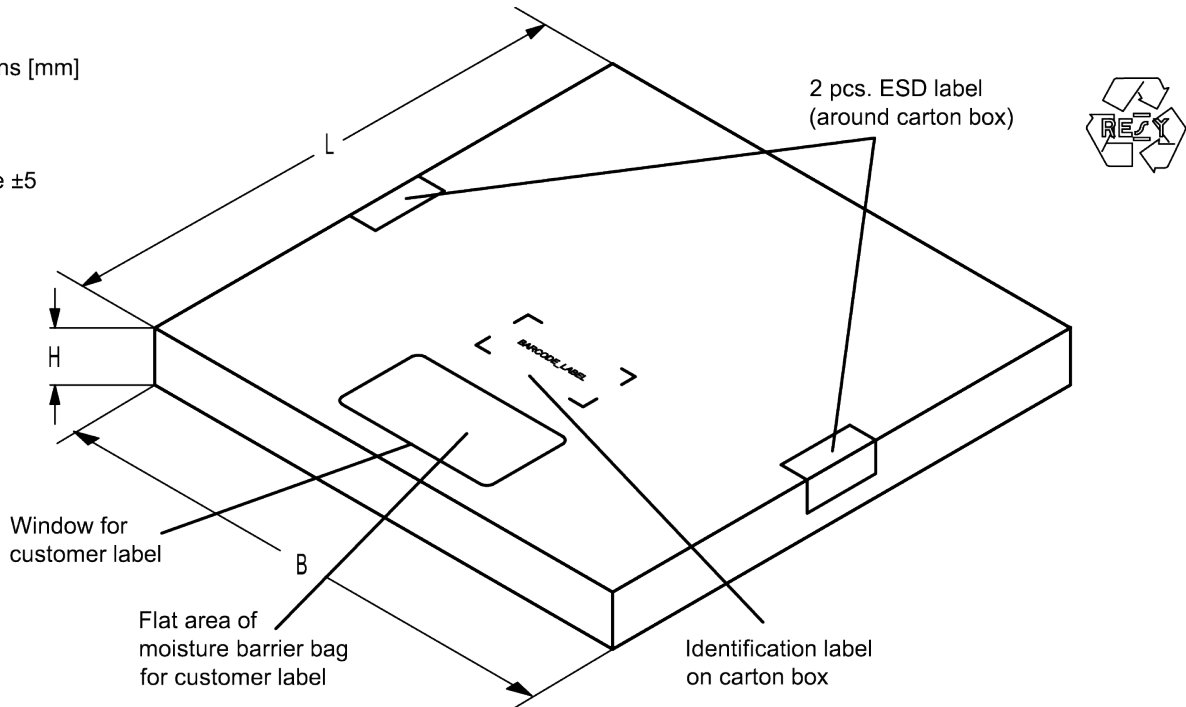

Figure 15: Drawing of folding box for reel with diameter of 180 mm.

11.3 Reel with diameter of 330 mm

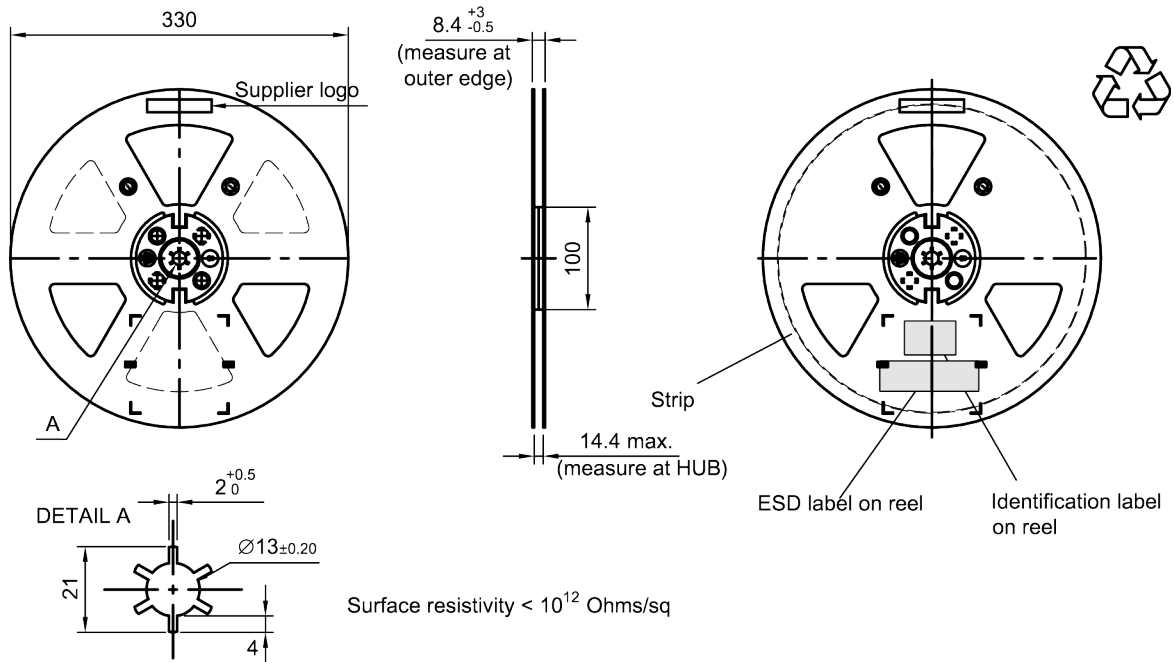

Figure 16: Drawing of reel (first-angle projection) with diameter of 330 mm.

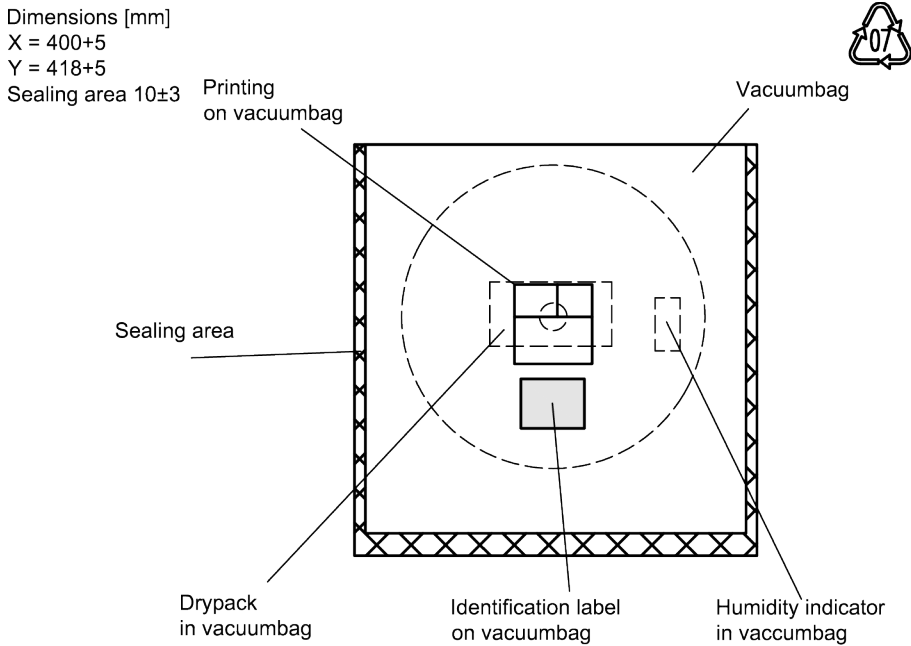

Figure 17: Drawing of moisture barrier bag (MBB) for reel with diameter of 330 mm.

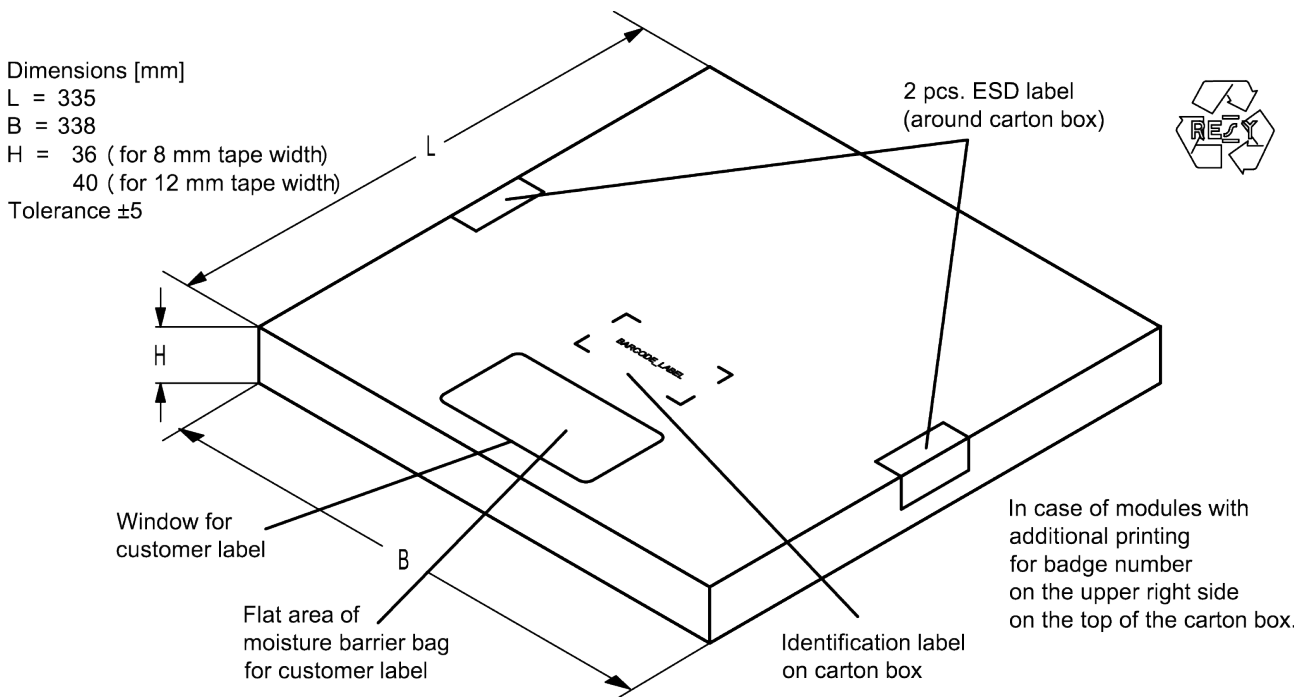

Figure 18: Drawing of folding box for reel with diameter of 330 mm.

12 Marking

Products are marked with product type number and lot number encoded according to Table 2:

■ Type number:

The 4 digit type number of the ordering code, e.g., B3xxxxB**1234**xxxx,
is encoded by a special BASE32 code into a 3 digit marking.

Example of decoding type number marking on device in decimal code.
16J => **1234**
 $1 \times 32^2 + 6 \times 32^1 + 18 (=J) \times 32^0 =$ **1234**
 The BASE32 code for product type B1244 is 16W.

■ Lot number:

The last 5 digits of the lot number, e.g., **12345**,
are encoded based on a special BASE47 code into a 3 digit marking.

Example of decoding lot number marking on device in decimal code.
5UY => **12345**
 $5 \times 47^2 + 27 (=U) \times 47^1 + 31 (=Y) \times 47^0 =$ **12345**

Adopted BASE32 code for type number			
Decimal value	Base32 code	Decimal value	Base32 code
0	0	16	G
1	1	17	H
2	2	18	J
3	3	19	K
4	4	20	M
5	5	21	N
6	6	22	P
7	7	23	Q
8	8	24	R
9	9	25	S
10	A	26	T
11	B	27	V
12	C	28	W
13	D	29	X
14	E	30	Y
15	F	31	Z

Adopted BASE47 code for lot number			
Decimal value	Base47 code	Decimal value	Base47 code
0	0	24	R
1	1	25	S
2	2	26	T
3	3	27	U
4	4	28	V
5	5	29	W
6	6	30	X
7	7	31	Y
8	8	32	Z
9	9	33	b
10	A	34	d
11	B	35	f
12	C	36	h
13	D	37	n
14	E	38	r
15	F	39	t
16	G	40	v
17	H	41	\
18	J	42	?
19	K	43	{
20	L	44	}
21	M	45	<
22	N	46	>
23	P		

Table 2: Lists for encoding and decoding of marking.

13 Soldering profile

The recommended soldering process is in accordance with IEC 60068-2-58 – 3rd edit and IPC/JEDEC J-STD-020B.

ramp rate	≤ 3 K/s
preheat	125 °C to 220 °C, 150 s to 210 s, 0.4 K/s to 1.0 K/s
T > 220 °C	30 s to 70 s
T > 230 °C	min. 10 s
T > 245 °C	max. 20 s
T ≥ 255 °C	–
peak temperature T_{peak}	250 °C +0/-5 °C
wetting temperature T_{min}	230 °C +5/-0 °C for 10 s ± 1 s
cooling rate	≤ 3 K/s
soldering temperature T	measured at solder pads

Table 3: Characteristics of recommended soldering profile for lead-free solder (Sn95.5Ag3.8Cu0.7).

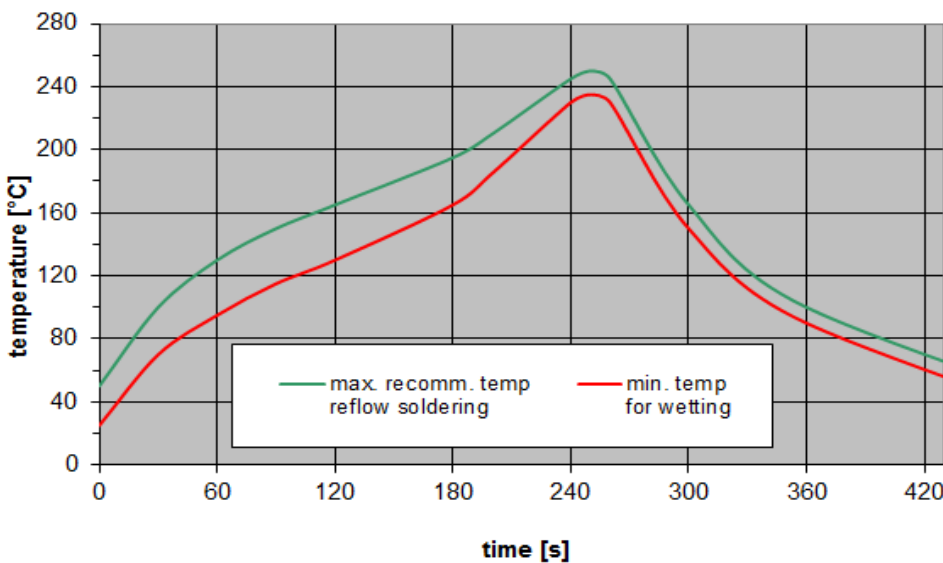

Figure 19: Recommended reflow profile for convection and infrared soldering – lead-free solder.

14 Annotations

14.1 Matching coils

See TDK inductor pdf-catalog <http://www.tdk.co.jp/tefe02/coil.htm#aname1> and Data Library for circuit simulation <http://www.tdk.co.jp/etvcl/index.htm>.

14.2 RoHS compatibility

ROHS-compatible means that products are compatible with the requirements according to Art. 4 (substance restrictions) of Directive 2011/65/EU of the European Parliament and of the Council of June 8th, 2011, on the restriction of the use of certain hazardous substances in electrical and electronic equipment ("Directive") with due regard to the application of exemptions as per Annex III of the Directive in certain cases.

14.3 Scattering parameters (S-parameters)

The pin/port assignment is available in the headers of the S-parameter files. Please contact your local RF360 sales office.

14.4 Ordering codes and packing units

Ordering code	Packing unit
B39202B1244P810	15000 pcs
B39202B1244P810S 5	5000 pcs

Table 4: Ordering codes and packing units.

15 Cautions and warnings

15.1 Display of ordering codes for RF360 products

The ordering code for one and the same product can be represented differently in data sheets, data books, other publications and the website of RF360, or in order-related documents such as shipping notes, order confirmations and product labels. The varying representations of the ordering codes are due to different processes employed and do not affect the specifications of the respective products. Detailed information can be found on the Internet under www.rf360jv.com/orderingcodes.

15.2 Material information

Due to technical requirements components may contain dangerous substances. For information on the type in question please also contact one of our sales offices.

For information on recycling of tapes and reels please contact one of our sales offices.

15.3 Moldability

Before using in overmolding environment, please contact your local RF360 sales office.

15.4 Package information

Landing area

The printed circuit board (PCB) land pattern (landing area) shown is based on RF360 internal development and empirical data and illustrated for example purposes, only. As customers' SMD assembly processes may have a plenty of variants and influence factors which are not under control or knowledge of RF360, additional careful process development on customer side is necessary and strongly recommended in order to achieve best soldering results tailored to the particular customer needs.

Dimensions

Unless otherwise specified all dimensions are understood using unit millimeter (mm).

Projection method

Unless otherwise specified first-angle projection is applied.

16 Important notes

The following applies to all products named in this publication:

1. Some parts of this publication contain **statements about the suitability of our products for certain areas of application**. These statements are based on our knowledge of typical requirements that are often placed on our products in the areas of application concerned. We nevertheless expressly point out **that such statements cannot be regarded as binding statements about the suitability of our products for a particular customer application**. As a rule, RF360 Europe GmbH and its affiliates are either unfamiliar with individual customer applications or less familiar with them than the customers themselves. For these reasons, it is always ultimately incumbent on the customer to check and decide whether an RF360 product with the properties described in the product specification is suitable for use in a particular customer application.
2. We also point out that **in individual cases, a malfunction of electronic components or failure before the end of their usual service life cannot be completely ruled out in the current state of the art, even if they are operated as specified**. In customer applications requiring a very high level of operational safety and especially in customer applications in which the malfunction or failure of an electronic component could endanger human life or health (e.g. in accident prevention or life-saving systems), it must therefore be ensured by means of suitable design of the customer application or other action taken by the customer (e.g. installation of protective circuitry or redundancy) that no injury or damage is sustained by third parties in the event of malfunction or failure of an electronic component.
3. **The warnings, cautions and product-specific notes must be observed.**
4. In order to satisfy certain technical requirements, **some of the products described in this publication may contain substances subject to restrictions in certain jurisdictions (e.g. because they are classed as hazardous)**. Useful information on this will be found in our Material Data Sheets on the Internet (www.rf360jv.com/material). Should you have any more detailed questions, please contact our sales offices.
5. We constantly strive to improve our products. Consequently, **the products described in this publication may change from time to time**. The same is true of the corresponding product specifications. Please check therefore to what extent product descriptions and specifications contained in this publication are still applicable before or when you place an order. We also **reserve the right to discontinue production and delivery of products**. Consequently, we cannot guarantee that all products named in this publication will always be available.
The aforementioned does not apply in the case of individual agreements deviating from the foregoing for customer-specific products.

单击下面可查看定价，库存，交付和生命周期等信息

[>>Qualcomm-RF360](#)