



Thick Film High Power Chip Resistors
(RMHF series standard)
Halogen-Free
AEC-Q200 qualified

Document No.	TRMHF-XX9F001A
Revise Date	2021/09/24
page number	1/14

1. Scope :

This specification applies for the thick film high power chip resistors made by TA-I.

2. Construction :

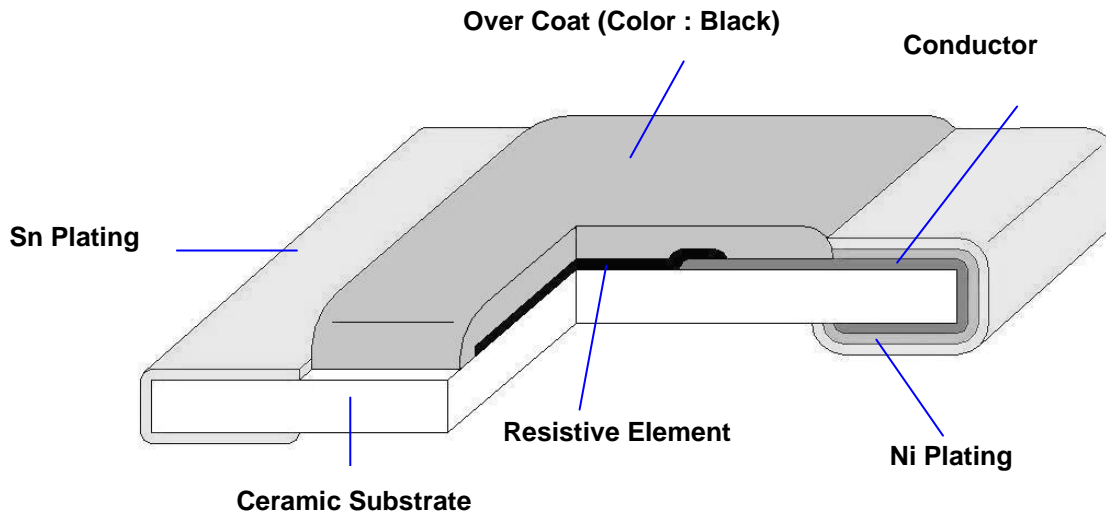

3.Type Designation :

RMHF

10

J

I

103

Product Code

Size

Tolerance

Packaging

Nominal

RMHF : High Power
Chip Resistor

Power Rating

Resistance

04-0402(1005)	1/8W	J-±5%	T- Paper Tape	3 digits, e.g., : (E-24) 103 = 10kΩ 4 digits, e.g., : (E-96) 1540 = 154Ω 43R2 = 43.2Ω
06-0603(1608)	1/5W	F-±1%	E- Emboss Tape	
10-0805(2012)	1/4W	D-±0.5%		
12-1206(3216)	1/2W			
20-2010(5025)	1W			
25-2512(6432)	2W			



Thick Film High Power Chip Resistors
(RMHF series standard)
Halogen-Free
AEC-Q200 qualified

Document No.	TRMHF-XX9F001A
Revise Date	2021/09/24
page number	2/14

4. Dimensions :

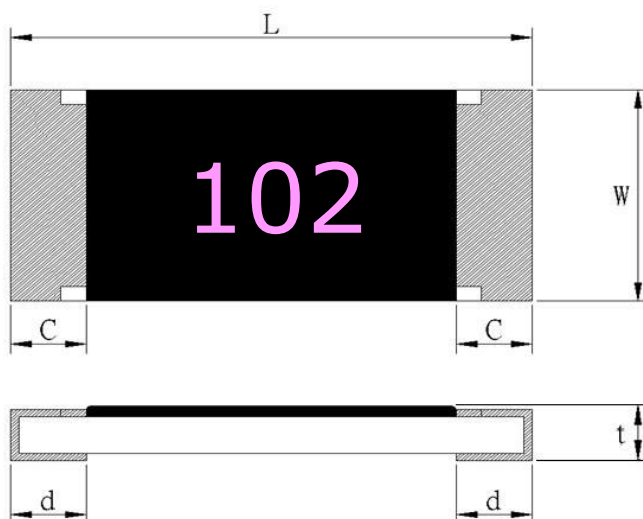

UNIT: mm

Type	L	W	C	d	t
RMHF04	1.00 ^{+0.10} _{-0.05}	0.50±0.05	0.20±0.10	0.25±0.10	0.32±0.05
RMHF06	1.60±0.10	0.80±0.10	0.30±0.20	0.30 ^{+0.2} _{-0.1}	0.45±0.10
RMHF10	2.00±0.10	1.25±0.10	0.40±0.20	0.40±0.20	0.50±0.10
RMHF12	3.10±0.10	1.55±0.10	0.50±0.30	0.40±0.20	0.55±0.10
RMHF20	5.00±0.15	2.50±0.15	0.60±0.30	0.50±0.25	0.60±0.10
RMHF25	6.30±0.20	3.20±0.20	0.60±0.30	0.50±0.25	0.60±0.10



Thick Film High Power Chip Resistors
(RMHF series standard)
Halogen-Free
AEC-Q200 qualified

Document No.	TRMHF-XX9F001A
Revise Date	2021/09/24
page number	3/14

5. Ratings & Characteristics :

Type	Power Rating at 70°C	Rating Voltage	Max. Working Voltage	Max. Over-Load Voltage	T.C.R (PPM/°C)	Resistance Range(Ω)		
						D(±0.5%) E-96&E-24	F(±1%) E-96&E-24	J(±5%) E-24
RMHF04	1/8W	Refer 5.2	50V	100V	±100	100Ω~1MΩ	100Ω~1MΩ	
					±200	10Ω ≤ R < 100Ω	10Ω ≤ R < 100Ω	10Ω-1MΩ
					+500 -200		1Ω ≤ R < 10Ω	1Ω ≤ R < 10Ω
RMHF06	1/5W	Refer 5.2	50V	100V	±100	10Ω~1MΩ	10Ω-1MΩ	
					±200			10Ω-1MΩ
					±400		1Ω ≤ R < 10Ω	1Ω ≤ R < 10Ω
RMHF10	1/4W	Refer 5.2	150V	300V	±100	10Ω~1MΩ	10Ω-1MΩ	
					±200			10Ω-1MΩ
					±400		1Ω ≤ R < 10Ω	1Ω ≤ R < 10Ω
RMHF12	1/2W	Refer 5.2	200V	400V	±100	10Ω~1MΩ	10Ω-1MΩ	
					±200			10Ω-1MΩ
					±400		1Ω ≤ R < 10Ω	1Ω ≤ R < 10Ω
RMHF20	1W	Refer 5.2	200V	400V	±100	10Ω~1MΩ	10Ω-1MΩ	
					±200			10Ω-1MΩ
					±400		1Ω ≤ R < 10Ω	1Ω ≤ R < 10Ω
RMHF25	2W	Refer 5.2	200V	400V	±100	10Ω~1MΩ	10Ω-1MΩ	
					±200			10Ω-1MΩ
					±400		1Ω ≤ R < 10Ω	1Ω ≤ R < 10Ω

Operating Temp(°C): -55°C ~ +155°C

Note : Except for the above standardized products, we also provide the customized products.



5.1 Derating Curve :

For resistors operated at ambient temperature over 70°C , power rating shall be derated in accordance with figure 1.

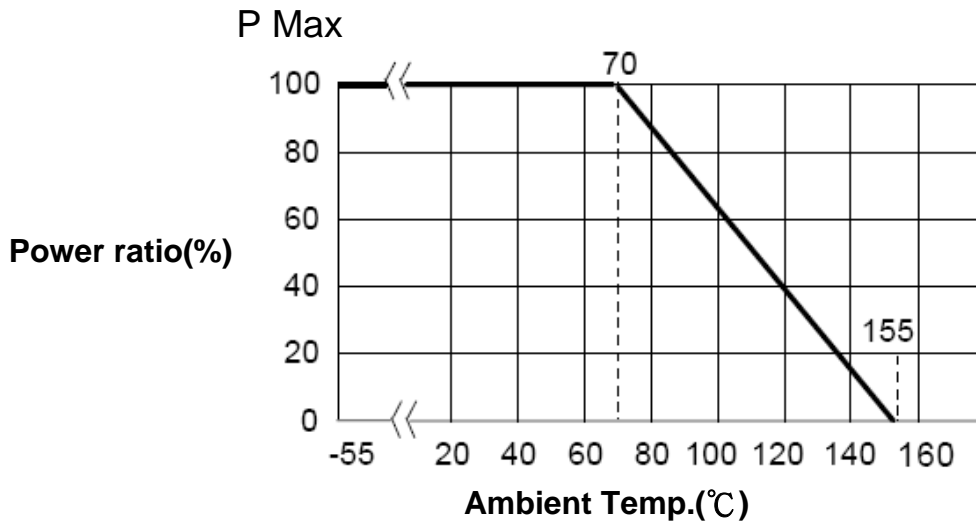

Figure 1

5.2 Rated Voltage :

The rated voltage is calculated by the following formula:

$$E = \sqrt{P * R}$$

E=Rated Voltage(V)
 P=Rated Power(W)
 R=Resistance Value(Ω)

E.G. : What is RMHF06JT102 the rated voltage ?

RMHF06JT102 P:1/5W ; R:102 = 1K Ω = 1000 Ω

$$E = \sqrt{0.2(W) * 1000(\Omega)} = 14.14 (V)$$



Thick Film High Power Chip Resistors
(RMHF series standard)
Halogen-Free
AEC-Q200 qualified

Document No.	TRMHF-XX9F001A
Revise Date	2021/09/24
page number	5/14

6. Reliability Tests :

Test Items	Reference standard	Condition of Test	Test Limits ΔR
Temperature Coefficient of Resistance	IEC 60115-1 4.8	-At +25/-55 °C and +25/+125 °C	Refer 5.0
Short Time Overload	IEC60115-1 4.13	2.5 X rated voltage for 5 sec	$\pm(1\% + 0.05\Omega)$ Remarks : 0201 : $\pm(3\% + 0.1\Omega)$ 0402 : $\pm(2\% + 0.1\Omega)$ 0 Ω : 50m Ω or less
High Temperature Exposure (Storage)	AEC-Q200-REV C-Test 3 MIL-STD-202 Method 108	1000 hrs. @ T=125°C. Unpowered. Measurement at 24 \pm 2 hours after test conclusion.	0.5%,1%: $\pm(1.0\%+0.05\Omega)$ 2%,5%: $\pm(2.0\%+0.1\Omega)$ 0201 : $\pm(3\% + 0.1\Omega)$ 0 Ω : 50m Ω or less
Moisture Resistance	AEC-Q200-REV C-Test 6 MIL-STD-202 Method 106	T=24 hours / Cycle ,10Cycles . Notes : Steps 7a& 7b not required. Unpowered .	0.5%,1%: $\pm(1.0\%+0.05\Omega)$ 2%,5%: $\pm(2.0\%+0.1\Omega)$ 0201 : $\pm(3\% + 0.1\Omega)$ 0 Ω : 50m Ω or less
Biased Humidity	AEC-Q200-REV C-Test 7 MIL-STD-202 Method 103	1000 hours 85°C/85%RH. Note: Specified conditions: 10% of operating power(not exceeding max working voltage). Measurement at 24 \pm 2 hours after test conclusion.	$\pm(3\% + 0.1\Omega)$ 0201 : $\pm(5\% + 0.1\Omega)$ 0 Ω : 100m Ω or less
Operational Life	AEC-Q200-REV C-Test 8 MIL-STD-202 Method 108	1000 hours TA=125°C at 35% rated power. Measurement at 24 \pm 4 hours after test conclusion.	0.5%,1%: $\pm(1\% + 0.1\Omega)$ 2%.5% : $\pm(3\% + 0.1\Omega)$ 0201 : $\pm(5\% + 0.1\Omega)$ 0 Ω : 100m Ω or less
External Visual	AEC-Q200-REV C-Test 9 MIL-STD-883 Method 2009	Electrical test not required. Inspect device construction, marking and workmanship.	
Physical Dimension	AEC-Q200-REV C-Test 10 JESD22 Method JB-100	Verify physical dimensions to the applicable device detail specification. Note: User(s) and Suppliers spec. Electrical test not required.	
Resistance to Solvents	AEC-Q200-REV C-Test 12 MIL-STD-202 Method 215	a:Isopropyl Alcohol : Mineral Spirits= 1 : 3 b:Terpene Defluxer (Bioact EC-7R) c:Deionized water : Propylene Glycol Monomethyl Ether : monoethanolamine = 42 : 1 : 1	Marking and protective layer can not be detached
Mechanical Shock	AEC-Q200-REV C-Test 13 MIL-STD-202 Method 213	Wave Form : Tolerance for half sine shock pulse. Peak value is 100g's. Normal duration(D) is 6(ms)	$\pm(1\% + 0.1\Omega)$ 0 Ω : 50m Ω or less
Vibration	AEC-Q200-REV C-Test 14 MIL-STD-202 Method 204	5 g's for 20 min., 12 cycles each of 3 orientations. Note: Test from 10-2000 Hz.	$\pm(1\% + 0.1\Omega)$ 0 Ω : 50m Ω or less
Resistance to Soldering Heat	AEC-Q200-REV C-Test 15 MIL-STD-202 Method 210	Condition B : Immerse the specimens in and eutectic solder at 260 \pm 5°C for 10 \pm 1S .	0.5%,1% : $\pm(0.5\% + 0.05\Omega)$ 2%.5% : $\pm(1\% + 0.1\Omega)$ 0201 : $\pm(2\% + 0.1\Omega)$ 0 Ω : 50m Ω or less
Thermal Shock	AEC-Q200-REV C-Test 16 MIL-STD-202 Method 107	-55°C/+155°C. Note: Number of cycles required-300, Maximum transfer time-20 seconds, Dwell time-15 minutes. Air-Air.	$\pm(1\% + 0.1\Omega)$ 0 Ω : 50m Ω or less



Thick Film High Power Chip Resistors
(RMHF series standard)
Halogen-Free
AEC-Q200 qualified

Document No.	TRMHF-XX9F001A
Revise Date	2021/09/24
page number	6/14

ESD	AEC-Q200-REV C-Test 17	verify the voltage setting at 500V	$\pm(1\% + 0.1\Omega)$ 0201 : $\pm(2\% + 0.1\Omega)$
Solderability	AEC-Q200-REV C-Test 18 J-STD-002	Method B, aging 4 hours at 155 °C dry heat Lead-free solder bath at 235±3 °C Dipping time: 3±0.5 seconds	> 95% area covered with tin
Flammability	AEC-Q200-REV C-Test 17 UL-94	V-0 or V-1 are acceptable. Electrical test not required.	V-0 or V-1
Board Flex (Bending)	AEC-Q200-REV C-Test 21	3mm deflection(RMF02~RMF13) 2mm deflection(RMF20~RMF25)	0.5%,1% : $\pm(0.5\% + 0.05\Omega)$ 2%.5% : $\pm(1\% + 0.1\Omega)$ 0201 : $\pm(1\% + 0.1\Omega)$ 0Ω : 50mΩ or less
Terminal Strength (SMD)	IEC 60115-1 4.32	Force of 1.02kg for 10±1 seconds. Remarks : RMF02:NA ,RMF04:0.51kg	$\pm(0.5\% + 0.05\Omega)$ 0Ω : 50mΩ or less

Note* : RCWV : Rated continuous working voltage .



Thick Film High Power Chip Resistors
(RMHF series standard)
Halogen-Free
AEC-Q200 qualified

Document No.	TRMHF-XX9F001A
Revise Date	2021/09/24
page number	7/14

7. Marking :

7.1 ±5%(E24) : RMHF06 / RMHF10 / RMHF12 / RMHF20 / RMHF25

Resistance value is expressed by 3 digits, the first two digits represent the significant figures of nominal resistance value in Ω , and the third digit represents exponent for base of 10.

E.G. :, 102 = $10 \times 10^2 = 1000 \Omega = 1K \Omega$



7.2 ±0.5% , ±1% (E96) : RMHF10 / RMHF12 / RMHF20/ RMHF25

Resistance value is expressed by 4 digits , the first three digits represent the significant figures of nominal resistance value in Ω , and the fourth digit represents exponent for base of 10.

E.G. : 1000 = $100 \times 10^0 = 100 \Omega$



7.3 ±0.5% , ±1% (E96): RMHF06

When the marking space is too small in such small-sized resistors as RMHF06, the marking can not made by 4 digits and may be made by two digits combined with one English capital.

Symbol for E96 series nominal resistance value

Symbol	E96	Symbol	E96	Symbol	E96	Symbol	E96
01	100	25	178	49	316	73	562
02	102	26	182	50	324	74	576
03	105	27	187	51	332	75	590
04	107	28	191	52	340	76	604
05	110	29	196	53	348	77	619
06	113	30	200	54	357	78	634
07	115	31	205	55	365	79	649
08	118	32	210	56	374	80	665
09	121	33	215	57	383	81	681
10	124	34	221	58	392	82	698
11	127	35	226	59	402	83	715
12	130	36	232	60	412	84	732
13	133	37	237	61	422	85	750
14	137	38	243	62	432	86	768
15	140	39	249	63	442	87	787
16	143	40	255	64	453	88	806
17	147	41	261	65	464	89	825
18	150	42	267	66	475	90	845



Thick Film High Power Chip Resistors
(RMHF series standard)
Halogen-Free
AEC-Q200 qualified

Document No.	TRMHF-XX9F001A
Revise Date	2021/09/24
page number	8/14

19	154	43	274	67	487	91	866
20	158	44	280	68	499	92	887
21	162	45	287	69	511	93	909
22	165	46	294	70	523	94	931
23	169	47	301	71	536	95	953
24	174	48	309	72	549	96	976

Symbol for multipliers

Symbol	A	B	C	D	E	F	G	H	X	Y	Z
multipliers	10 ⁰	10 ¹	10 ²	10 ³	10 ⁴	10 ⁵	10 ⁶	10 ⁷	10 ⁻¹	10 ⁻²	10 ⁻³

E.G : 01A = 100×10⁰ = 100Ω



Notes :

When the resistance value is not in the list of E96 , 3 digitals with underline in E-24 series is used as mark .

E.G. : 0603 , 120Ω , 1% Marking is 121



7.4 RMHF04 :

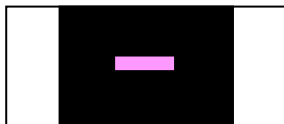



Thick Film High Power Chip Resistors
(RMHF series standard)
Halogen-Free
AEC-Q200 qualified

Document No.	TRMHF-XX9F001A
Revise Date	2021/09/24
page number	9/14

8. Taping & Reel :

8.1 Taping Dimensions

8.1.1 4 mm pitch paper:

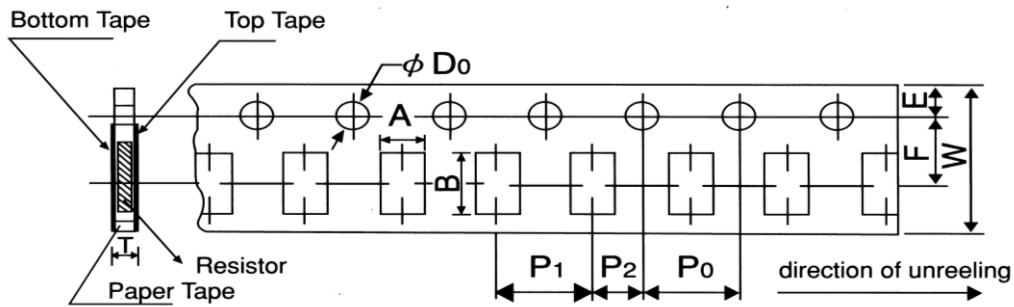

Packing	Type	A	B	W	F	E	P ₁	P ₂	P ₀	D ₀	T
Paper	RMHF06	1.1±0.1	1.9±0.1	8.0±0.2	3.5±0.05	1.75±0.1	4.0±0.1	2.0±0.05	4.0±0.1	φ 1.5	0.64±0.1
	RMHF10	1.6±0.15	2.4±0.2								+0.1
	RMHF12	2.0±0.15	3.6±0.2								-0

8.1.2 Taping Dimensions 2 mm pitch paper :

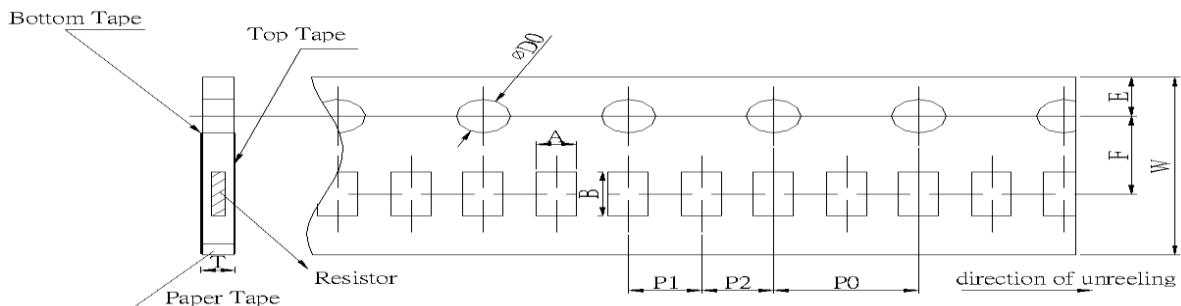

Packing	Type	A	B	W	F	E	P ₁	P ₂	P ₀	D ₀	T
Paper	RMHF04	0.7±0.05	1.2±0.05	8.0±0.2	3.5±0.05	1.75±0.1	2.0±0.1	2.0±0.1	4.0±0.1	φ 1.5	0.45±0.1



Thick Film High Power Chip Resistors
(RMHF series standard)
Halogen-Free
AEC-Q200 qualified

Document No.	TRMHF-XX9F001A
Revise Date	2021/09/24
page number	10/14

8.1.3 4 mm pitch Emboss :

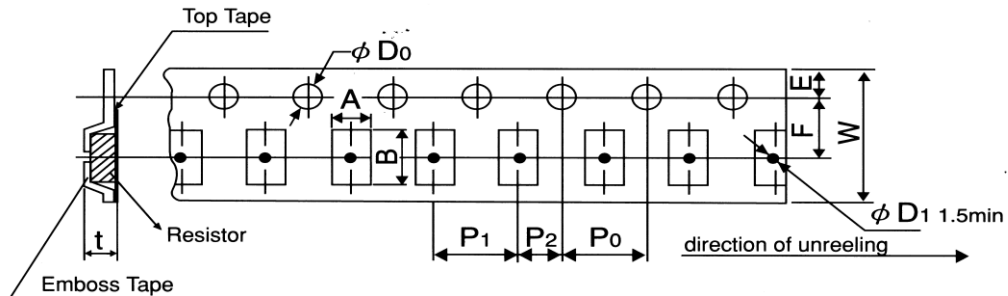

Packing	Type	A	B	W	F	E	P ₁	P ₂	P ₀	D ₀	T
Emboss	RMHF20	2.8±0.2	5.3±0.2	12.0±0.2	5.5±0.05	1.75±0.1	4.0±0.1	2.0±0.05	4.0±0.05	φ 1.5	0.85±0.15
	RMHF25	3.6±0.2	6.9±0.2								

UNIT: PCS

Type	Size	Paper Tape				Emboss Plastic Tape 4 mm pitch
		4 mm pitch		2 mm pitch		
		178mm/R	250mm/R	178mm/R	250mm/R	
RMHF	04			10000	20000	
RMHF	06	5000	10000			
RMHF	10	5000	10000			
RMHF	12	5000	10000			
RMHF	20					4000
RMHF	25					4000

8.3 Reel Specifications:

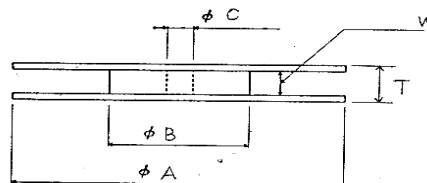
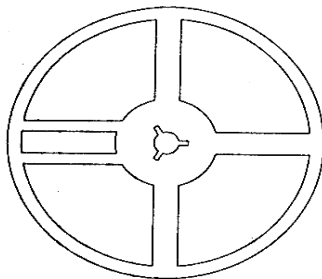

UNIT: mm

Type	φ A	φ B	φ C	W	T
RMHF04/06/10/12	178.0 ± 2.0	60.0 ± 1.0	13.0 ± 1.0	9.0 ± 1.0	11.5 ± 1.0
RMHF20/25				13.0 ± 1.0	15.5 ± 1.0

TA-I TECHNOLOGY CO., LTD



Thick Film High Power Chip Resistors
(RMHF series standard)
Halogen-Free
AEC-Q200 qualified

Document No.	TRMHF-XX9F001A
Revise Date	2021/09/24
page number	11/14

8.4. Peel –off force :

Peel –off force of paper and blister tape is in accordance with “JIS-C5202 ” that is , 0.1 to 0.7 N at a peel-off speed of 300 mm / minute.

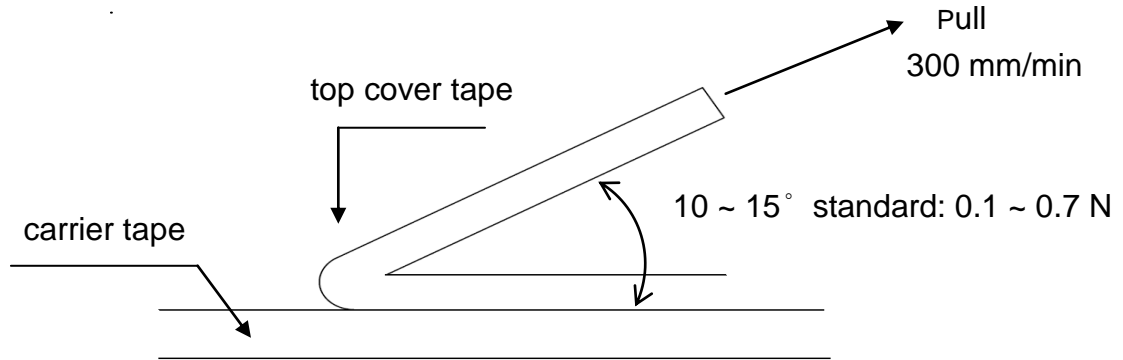

9. Label :

9.1 Manufacture Label :

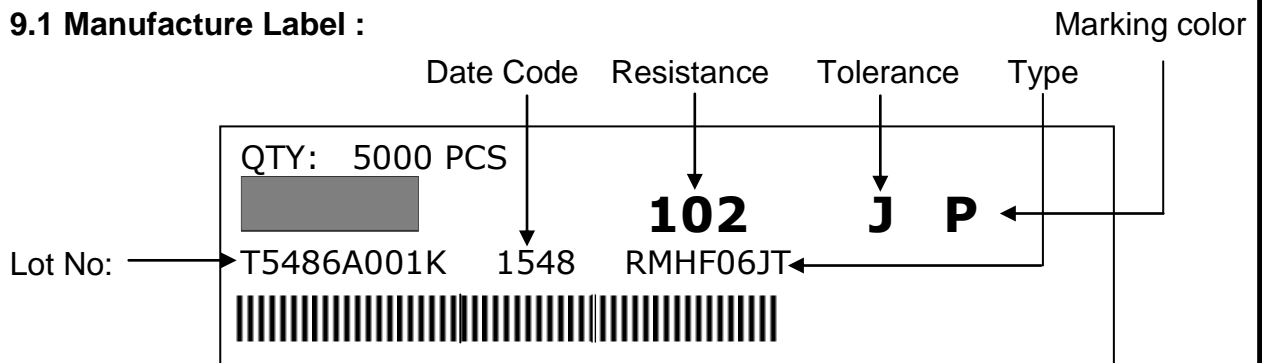

9.2 Customer Label (By customer request):





Thick Film High Power Chip Resistors
(RMHF series standard)
Halogen-Free
AEC-Q200 qualified

Document No.	TRMHF-XX9F001A
Revise Date	2021/09/24
page number	12/14

10. Recommended land patterns :

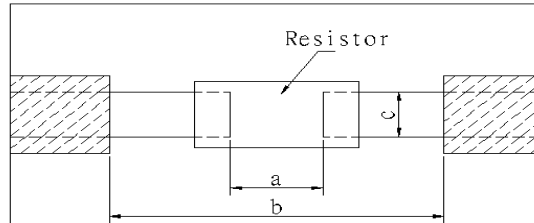

Land pattern		Dimension (mm)		
Type	Size	a	b	c
RMHF	04 (0402)	0.50~0.6	1.4~1.6	0.4~0.6
RMHF	06 (0603)	0.7~0.9	2.0~2.2	0.8~1.0
RMHF	10 (0805)	1.0~1.4	3.2~3.8	0.9~1.4
RMHF	12 (1206)	2.0~2.4	4.4~5.0	1.2~1.8
RMHF	20 (2010)	3.3~3.7	5.7~6.5	2.3~3.5
RMHF	25 (2512)	3.6~4.0	7.6~8.6	2.3~3.5

11. Recommend IR – Reflow profile : (solder : Sn96.5 / Ag3 / Cu0.5)

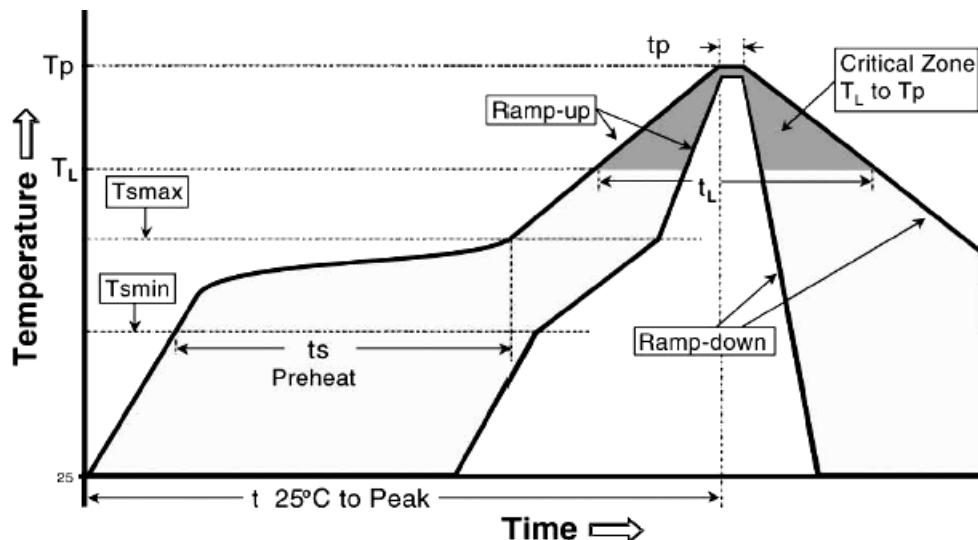

Allowed Re-flow times : 3 times

Remark : To avoid discoloration phenomena of chip on terminal electrodes,
please use N2 Re-flow furnace .



Thick Film High Power Chip Resistors
(RMHF series standard)
Halogen-Free
AEC-Q200 qualified

Document No.	TRMHF-XX9F001A
Revise Date	2021/09/24
page number	13/14

Profile Feature	Lead (Pb)-Free Assembly
Average ramp-up rate (T _{smax} to T _p)	3°C / second max.
Preheat - Temperature Min (T _{smin}) - Temperature Max (T _{smax}) - Time (T _{smin} to T _{smax}) (ts)	150°C 200°C 60 -120 seconds
Time maintained above : - Temperature (T _L) - Time (T _L)	217°C 60-150 seconds
Peak Temperature (T _p)	260°C
Time within $\begin{matrix} +0 \\ -5 \end{matrix}$ °C of actual Peak Temperature (tp) ²	10 seconds
Ramp-down Rate	6°C/second max.
Time 25°C to Peak Temperature	8mimutes max.

12. Storage Conditions:

Temperature: 5°C~35°C, Humidity:40%~75%

13. Shelf Life:

2 years from manufacturing date.

14. ECN :

Engineering Change Notice: The customer will be informed with ECN if there is significant modification on the characteristics and materials described in Approval Sheet.



Thick Film High Power Chip Resistors
(RMHF series standard)
Halogen-Free
AEC-Q200 qualified

Document No.	TRMHF-XX9F001A
Revise Date	2021/09/24
page number	14/14

15. Manufacturing Country & City :

TA-I TECHNOLOGY CO., LTD. (Taiwan– Tao Yuan)
Tel : 886-3-3246169 Fax : 886-3-3246167

TA-I TECHNOLOGY (SU ZHOU) CO., LTD. (China – Su Zhou)
Tel : 86- 512-63457879 Fax : 86-512-63457869

Associated companies :

(1) FORTUNE TASK RESISTOR FACTORY (China – Dongguan)
Tel : 86-769-8339-4790~3 Fax : 86-769-8339-4794

(2) TA-I TECHNOLOGY (DONGGUAN) CO., LTD. (China –Dongguan)
Tel : 86-769-8339-4790~3 Fax : 86-769-8339-4794

(3) TAI OHM ELECTRONICS (M) SDN. BHD. (Malaysia – Penang)
Tel : 604- 3900480 Fax : 604-3901481

(4) P.T.TAI ELECTRONICS Indonesia (Indonesia – Jakarta)
Tel : 62-21-89830123 Fax : 62-21-89830703

TA-I TECHNOLOGY CO., LTD

单击下面可查看定价，库存，交付和生命周期等信息

[>>TA-I\(大毅\)](#)