

ABG-N Series

Features

- Magnetic-resin shielded construction reduces buzz noise to ultra-low levels.
- Metallization on Ferrite Core results in excellent shock resistance and damage-free durability.
- Closed magnetic circuit design reduces leakage flux and Electro Magnetic Interference(EMI) .
- 40% high current rating than conventional inductors of equal size.
- Takes up less PCB real estate and save more power.
- RoHS compliance.

Applications

- LED Lighting
- Next-generation mobile devices with multifunction such as adding color TV and digital movie cameras
- Flat-screen TVs,blue-ray disc recorders set top box
- Notebooks,desktop computers,servers,graphic cards
- Portable gaming devices,personal navigation systems,personal multimedia devices

Test Equipment and Conditions

- Inductance is measured with IM3536 LCR meter or equivalent.
- Operating temperature range -40°C to +125°C(Including self - temperature rise).
- DC current(Irms)that will cause an approximate ΔT of 40°C .
- DC current(Isat)that will cause L0 to drop approximately 40%.

External Dimensions (Unit:m/m)

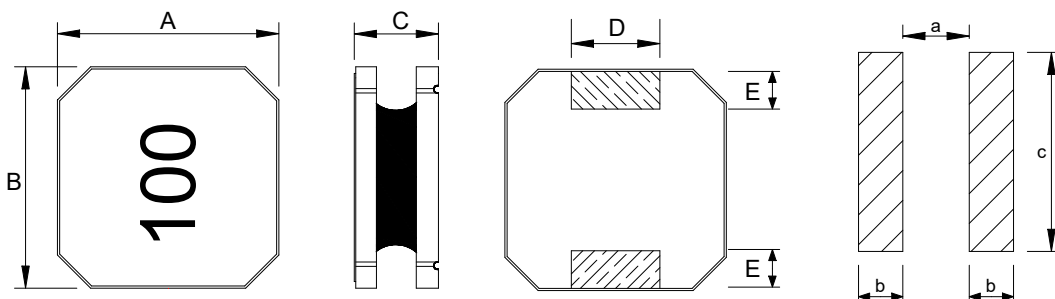

Type	A	B	C	D	E	a	b	c	Q'TY/Reel
ABG10N50	10.0±0.3	10.0±0.3	5.1Max	4.2Ref	1.7Ref	6.2Ref	2.0Ref	5.5Ref	700

Part Number Code

ABG 10 N 50 M 100
 A B C D E F

A: Series Name Power Inductors
 B: Dimensions(mm) 10: 10.0x10.0
 C: Materials N Type
 D: Thickness(mm) 50: 5.1 Max
 E: Tolerance M: ±20%
 F: Inductance 100=10uH

ABG-N Series

Part Number	Inductance (μ H) @100KHz/1V	DC Resistance (m Ω) \pm 30%	Heat Rating Current I _{rms} (A)	Saturation Current I _{sat} (A)
ABG10N50M1R0	1.0	10	10.0	12.0
ABG10N50M1R5	1.5	11	9.0	11.8
ABG10N50M2R2	2.2	12	8.0	11.3
ABG10N50M3R3	3.3	14	7.5	10.7
ABG10N50M3R8	3.8	13	6.8	7.3
ABG10N50M4R7	4.7	15	6.8	10.0
ABG10N50M5R6	5.6	23	6.5	9.8
ABG10N50M6R8	6.8	24	5.9	9.5
ABG10N50M8R2	8.2	27	5.5	9.0
ABG10N50M100	10	35	4.4	8.2
ABG10N50M150	15	41	3.9	7.0
ABG10N50M220	22	50	3.6	5.8
ABG10N50M330	33	71	3.3	5.0
ABG10N50M470	47	112	2.8	4.0
ABG10N50M560	56	150	2.4	3.5
ABG10N50M680	68	160	2.3	3.3
ABG10N50M820	82	185	2.1	2.8
ABG10N50M101	100	240	1.7	2.5
ABG10N50M151	150	390	1.3	2.2
ABG10N50M221	220	560	1.1	1.8
ABG10N50M271	270	700	0.88	1.6
ABG10N50M331	330	840	0.85	1.4
ABG10N50M391	390	1000	0.66	1.2
ABG10N50M471	470	1260	0.7	0.5
ABG10N50M561	560	1500	0.6	0.5
ABG10N50M681	680	1540	0.65	1.0
ABG10N50M102	1000	2770	0.4	0.5
ABG10N50M332	3300	8310	0.23	0.36
ABG10N50M103	10000	23000	0.09	0.1

Curve:

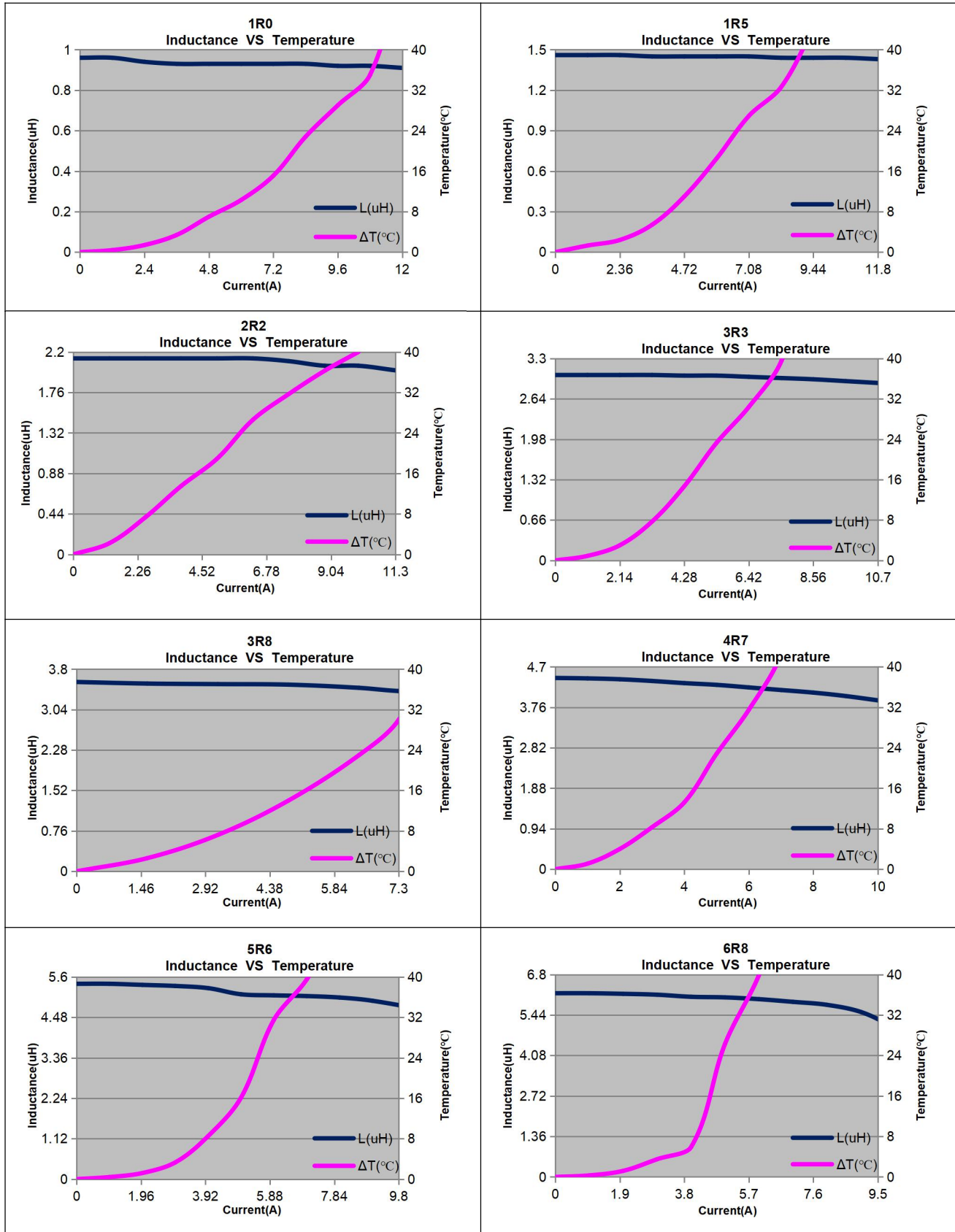

Curve:

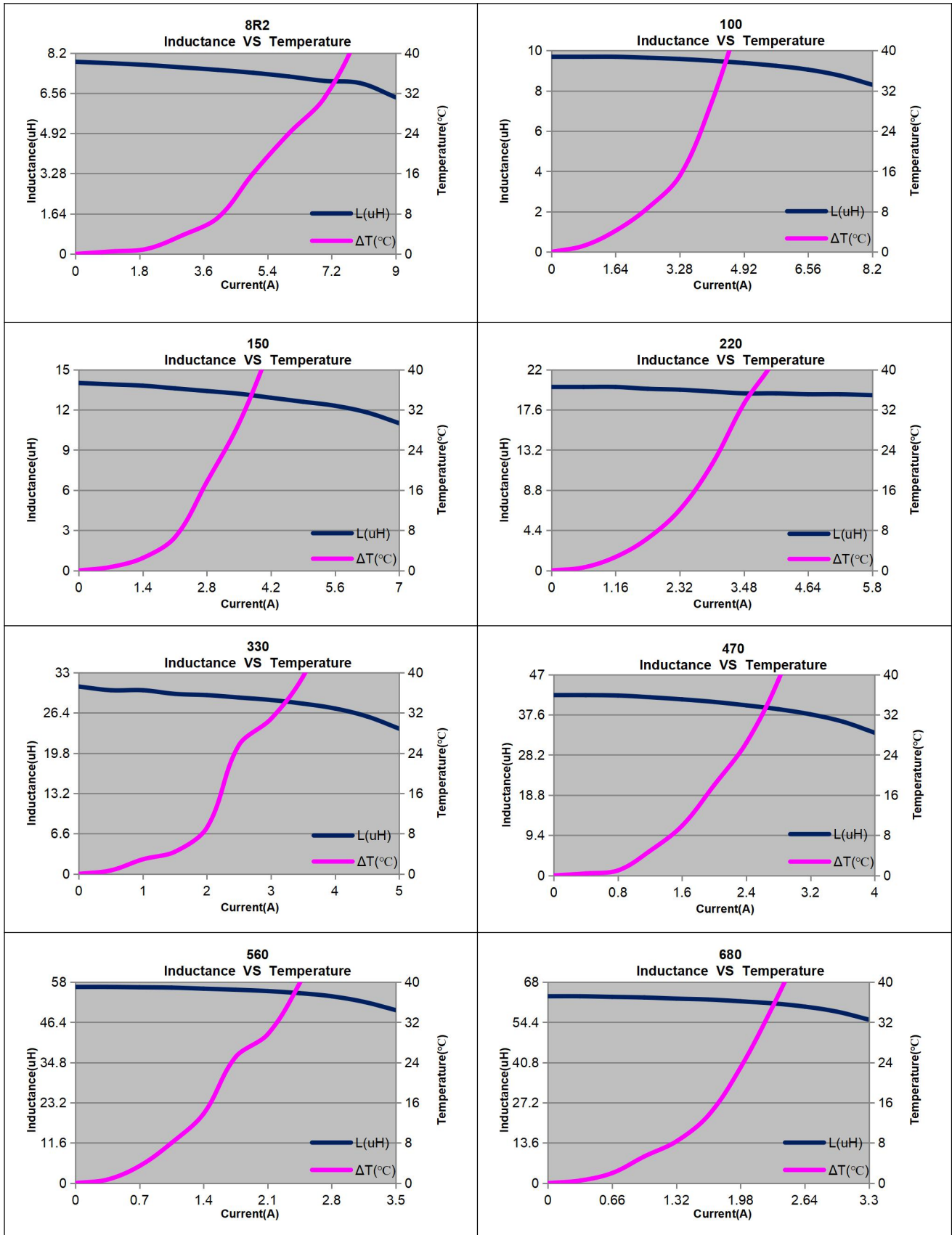

Curve:

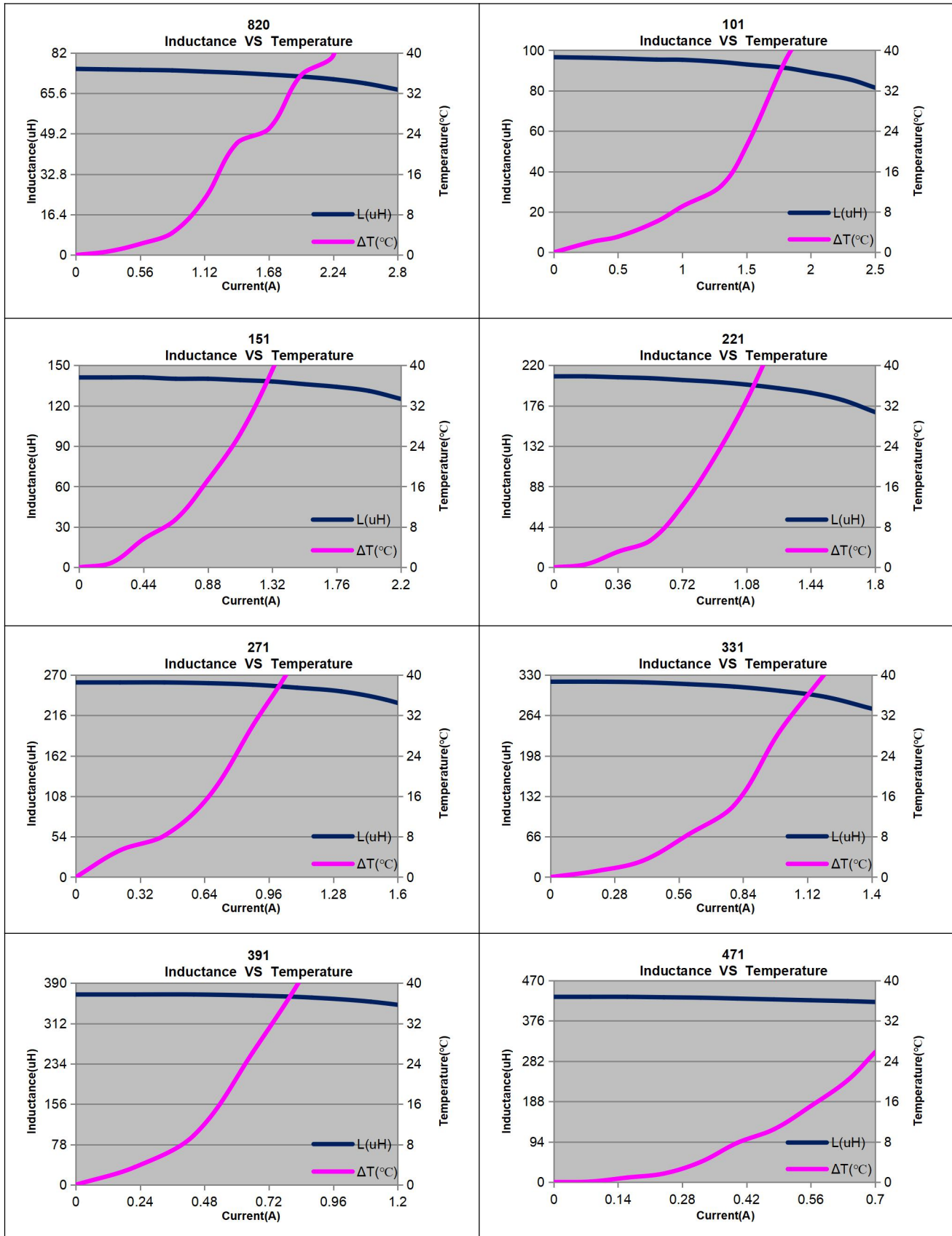

Curve:

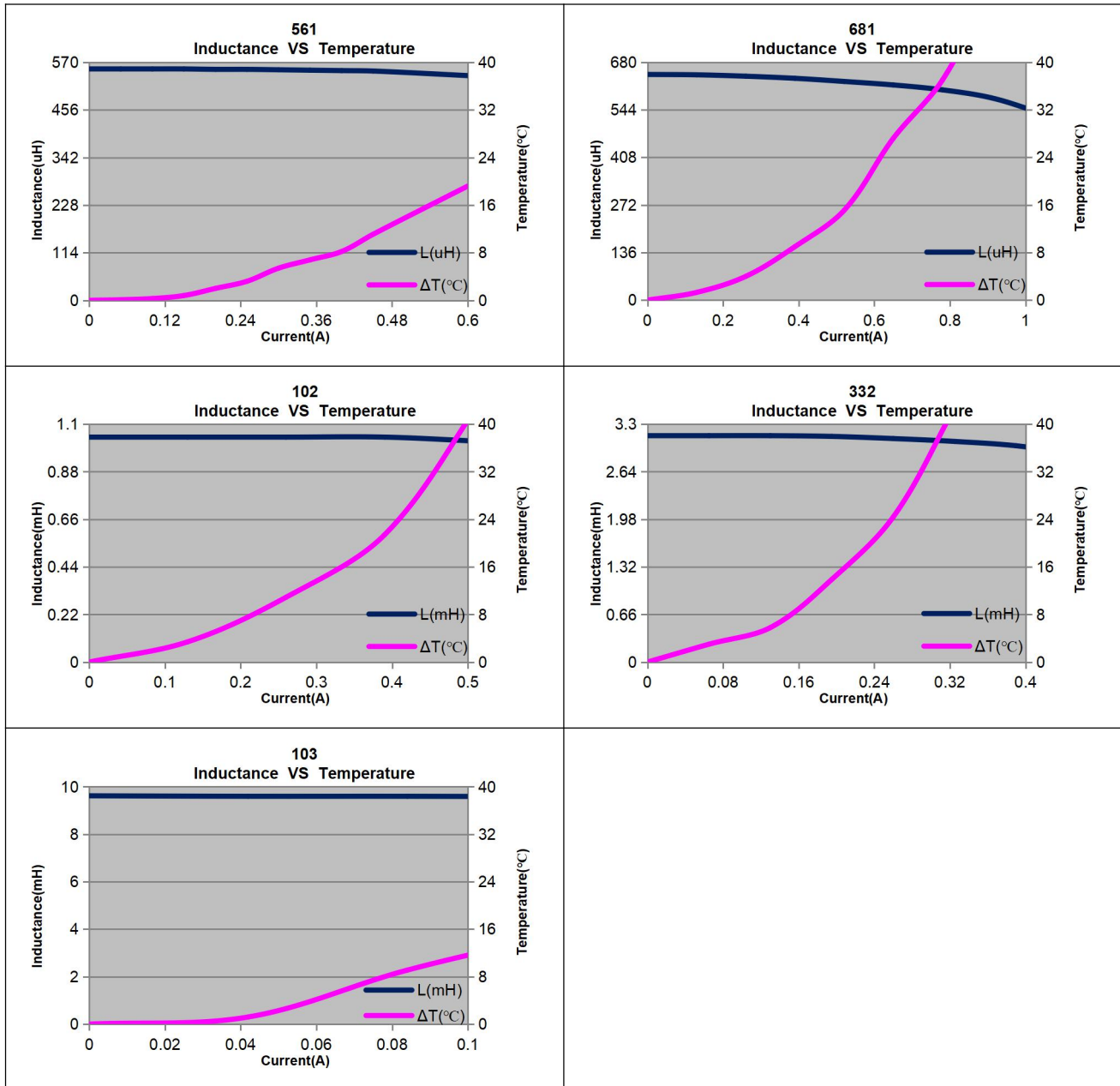

Reliability Test

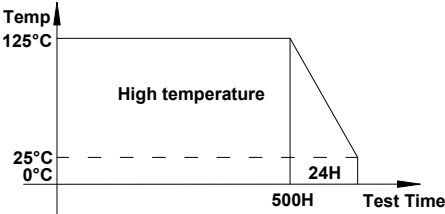
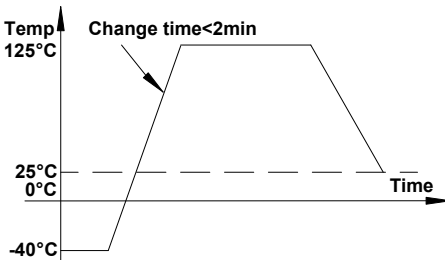
Item	Specifications	Test conditions
High temperature storage test	No visible mechanical damage. Inductance change: Within $\pm 10\%$.	<p>Temperature: $125 \pm 2^\circ\text{C}$. Duration: 500hrs. Measured at room temperature after placing for 24 ± 4 hrs.</p>  <p>The graph shows temperature on the y-axis with markers at 125°C, 25°C, and 0°C. The x-axis is labeled 'Test Time' with markers at 500H and 24H. A horizontal line is at 125°C from the start to 500H, labeled 'High temperature'. From 500H, the temperature decreases linearly to 25°C at 24H, and then continues to decrease to 0°C.</p>
Temperature cycling test	No visible mechanical damage. Inductance change: Within $\pm 10\%$.	<p>Condition for 1 cycle. Step1: $-40 \pm 2^\circ\text{C}$ 30min Min. Step2: $125 \pm 2^\circ\text{C}$, transition time 2min Max. Step3: $125 \pm 2^\circ\text{C}$ 30min Min. Step4: Low temp, transition time 2min Max. Number of cycles: 100. Measured at room temperature after placing for 24 ± 4 hrs.</p>  <p>The graph shows temperature on the y-axis with markers at 125°C, 25°C, 0°C, and -40°C. The x-axis is labeled 'Time'. The temperature starts at -40°C, rises linearly to 125°C (labeled 'Change time < 2min'), stays at 125°C for a period, then falls linearly back to -40°C.</p>
Biased humidity test	No visible mechanical damage. Inductance change: Within $\pm 10\%$.	<p>Humidity : $85\% \pm 3$ RH. Temperature: $60^\circ\text{C} \pm 2^\circ\text{C}$. Duration : 500hrs. Measured at room temperature after placing for 24 ± 4 hrs.</p>
Operational life test	No visible mechanical damage. Inductance change: Within $\pm 10\%$.	<p>Temperature: $85 \pm 2^\circ\text{C}$. Duration : 500hrs. Measured at room temperature after placing for 24 ± 4 hrs.</p>
Resistance to solvent test	No visible mechanical damage. Inductance change: Within $\pm 10\%$.	Add aqueous wash chemical - OKEM clean or equivalent.
Vibration test	No visible mechanical damage. Inductance change: Within $\pm 10\%$.	The sample shall be soldered onto the printed circuit board and when a vibration having an amplitude of 1.52mm and a frequency of from 10 to 55Hz/1 minute repeated should be applied to the 3 directions (X,Y,Z) for 2 hours each.(A total of 6 hours)

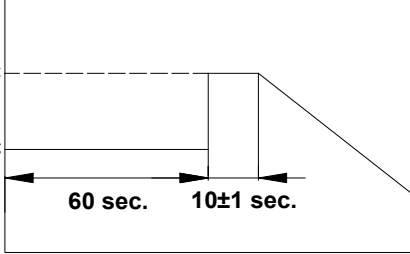
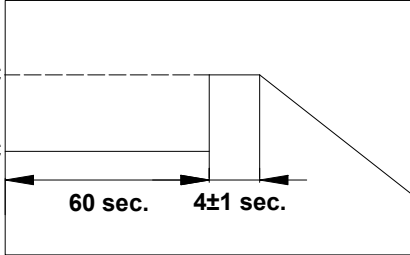
Item	Specifications	Test conditions
Resistance to soldering heat test	No visible mechanical damage. Inductance change: Within $\pm 10\%$.	Temperature ($^{\circ}\text{C}$): 260 ± 5 (solder temp). Time (s): 10 ± 1 . ramp/immersion and emersion rate: $25\text{mm/s} \pm 6 \text{ mm/s}$. Number of heat cycles: 1. 
Solderability test	More than 95% of the terminal electrode should be covered with solder.	Steam Aging: 8 hours \pm 15 min. Preheat: 150°C , 60sec. Solder: Sn99.5%-Cu0. 5%. Temperature: $245 \pm 5^{\circ}\text{C}$. Flux for lead free: Rosin. 9.5%. Dip time: 4 ± 1 sec. Depth: completely cover the termination. 
Terminal strength (SMD) test	No visible mechanical damage.	With the component mounted on a PCB with the device to be tested, apply a 10 N force to the side of a device being tested. This force shall be applied for 10 ± 1 seconds. Also the force shall be applied radually as not to apply a shock to the component being tested.

Packaging (Unit:mm)

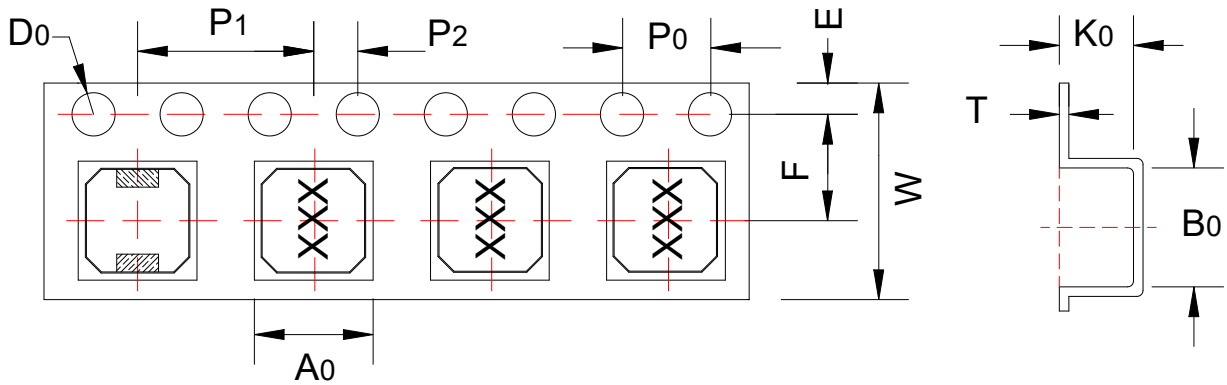

TYPE	A0	B0	W	E	F	P0	P1	P2	D0	T	K0
ABG10N50	10.5±0.1	10.5±0.1	24.0±0.3	1.75±0.1	11.5±0.1	4.0±0.1	16.0±0.1	2.0±0.1	1.5±0.1	0.4±0.1	5.3±0.1

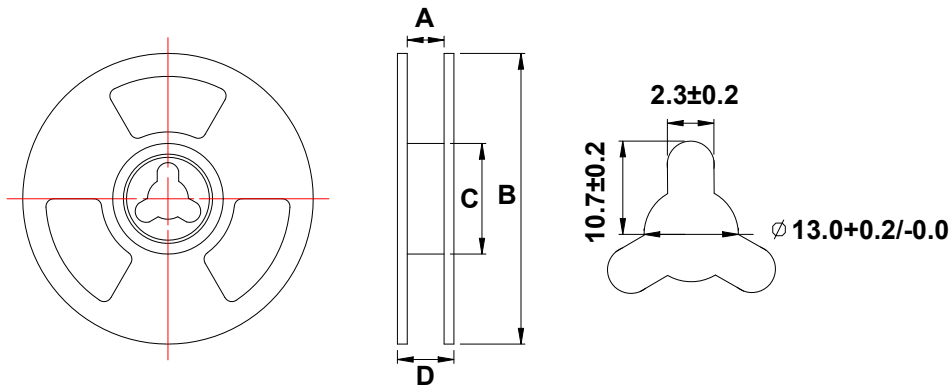

TYPE	A	B	C	D
ABG10N50	24.5±2.0	330.0±2.0	100.0±2.0	28.5±2.0

Recommended Soldering Technologies

Re-flowing Profile:

- △ Preheat condition: 150~200°C/60~120sec.
- △ Allowed time above 217°C: 60~90sec.
- △ Max temp: 260°C
- △ Max time at max temp: 5sec.
- △ Solder paste: Sn/3.0Ag/0.5Cu
- △ Allowed Reflow time: 2x max

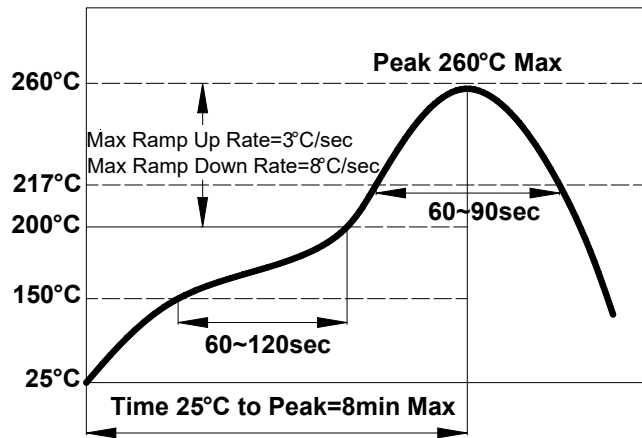

Iron Soldering Profile:

- △ Iron soldering power: Max.30W
- △ Pre-heating: 150°C/60sec.
- △ Soldering Tip temperature: 350°CMax.
- △ Soldering time: 3sec Max.
- △ Solder paste: Sn/3.0Ag/0.5Cu
- △ Max.1 times for iron soldering

[Note: Take care not to apply the tip of the soldering iron to the]

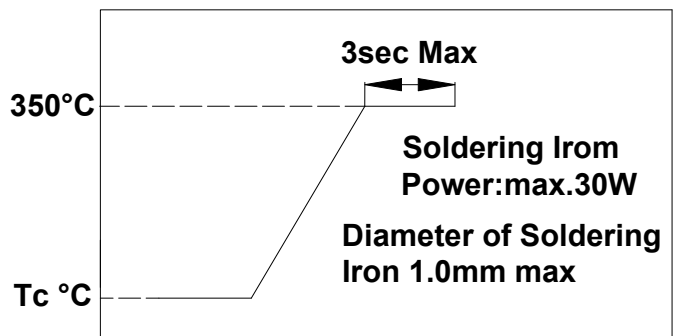

单击下面可查看定价，库存，交付和生命周期等信息

[>>Coilank\(驰兴\)](#)