

HOLDER COMPANY

Issue : 20160493

Date of issue : Apr 15,2016

Classification : New Change

PRODUCT SPECIFICATION FOR APPROVAL

Product Description : LIGHT TOUCH SWITCH

Product Part Number : (Panasonic Part Number : EVPBB4A9BT01)

Country of Origin : Japan,Malaysia,China (It is indicated in the packing label with English)

Applications : It depends on 1.2[Application Limits]

*If you approve this specification, please fill in and sign the below and return 1 copy to us.

Approval :	
Approval Date :	
Executed by :	
	_____ (Signature)
Title :	
Dept. :	

Electromechanical Control Business Division
Panasonic Corporation

1006 Kadoma, Kadoma City, Osaka, Japan

Phone: +81-6-6908-7304 (Direct)

Prepared by : Input Devices Business Unit
Engineering Department 1

Contact Person : *K. Koumoto*
Signature : _____
Name (Print) : K. KOUMOTO
Title :
Phone : +81-868-26-3791

Authorized by : *D. Nakata*
Signature : _____
Name (Print) : D.NAKATA
Title : Team leader of Engineering



Classification	SPECIFICATION	Issue No. 20160493						
Part Name 2.6mm x 1.6mm SMD Light Touch Switch	Part No. EVPBB4A9BT01	1 / 8						
<p>1. Notification Items</p> <p>1.1 Law and the regulation which are applied</p> <p>Ozone depleting substances specified by Montreal Protocol have not been used in the manufacturing process of the material used in this product.</p> <p>This product complies with RoHS Directive (on the restriction of the use of certain hazardous substances in electrical and electronic equipment) (2011/65/EU).</p> <p>The materials used in this product contain only the substances listed in the List of Existing Chemical Substances specified in 'Act on the Evaluation of Chemical Substances and Regulation of Their Manufacture, etc'.</p> <p>Permission must be obtained from the Japanese government if the product that is subject to the "Foreign Exchange and Foreign Trade Law" is to be exported or taken out of Japan.</p> <p>1.2 Application Limits</p> <p>The following shall be described for safety precaution:</p> <p>[Limitation of Application]</p> <ul style="list-style-type: none"> - This product has been designed and manufactured for general electronic devices, such as home electronics, office equipment, information device and communication devices. In an event that this product is used for more sophisticated applications requiring higher safety and reliability and its failure or malfunction of this product may impose damage to human life or property, agreement on product specifications for approval suitable for such applications are required. Such applications shall include the following: <ul style="list-style-type: none"> aircraft equipment, aerospace equipment, disaster prevention / crime prevention equipment, medical equipment, transportation equipment (vehicles, trains, ships, etc.), information processing equipment that are highly publicized, and other equivalent equipment - Regardless of its applications, in an event that this product is used for the equipment requiring high safety levels, place protective circuits or redundant circuits and perform safety tests to improve your products safety. <p>1.3 Handling of approval specification</p> <ul style="list-style-type: none"> · Writings in this specification form are subject to change through precautions. · This specification form specify this item only. Please perform your approval test in the actual application conditions beforehand. · Please return one copy of this specification form with your approval stamp or signature to us. Otherwise, it might be happened that the item can not be supplied. <p>1.4 Manufacturing Sites</p> <table style="width: 100%; border: none;"> <tr> <td style="width: 35%;">The country of manufacture : Malaysia</td> <td>Panasonic Industrial Devices Malaysia Sdn. Bhd.</td> </tr> <tr> <td>The country of manufacture : China</td> <td>Panasonic Industrial Devices (Qingdao) Co., Ltd.</td> </tr> <tr> <td>The country of manufacture : Japan</td> <td>Input Devices Business Unit, Electromechanical Control Business Division Panasonic Corporation</td> </tr> </table> <p>2. Summary</p> <p>2.1 This specifications applies to the following types of switch. Push-ON type S.P.S.T</p> <p>2.2 This specifications is a constituent document of contract for business concluded between your company and Panasonic Corporation.</p> <p>2.3 Items not particularly specified in this specifications shall be in conformance with JIS Standards.</p>			The country of manufacture : Malaysia	Panasonic Industrial Devices Malaysia Sdn. Bhd.	The country of manufacture : China	Panasonic Industrial Devices (Qingdao) Co., Ltd.	The country of manufacture : Japan	Input Devices Business Unit, Electromechanical Control Business Division Panasonic Corporation
The country of manufacture : Malaysia	Panasonic Industrial Devices Malaysia Sdn. Bhd.							
The country of manufacture : China	Panasonic Industrial Devices (Qingdao) Co., Ltd.							
The country of manufacture : Japan	Input Devices Business Unit, Electromechanical Control Business Division Panasonic Corporation							

Classification	SPECIFICATION	Issue No. 20160493
Part Name 2.6mm x 1.6mm SMD Light Touch Switch	Part No. EVPBB4A9BT01	2 / 8

3. Dimension · Marking · Circuit diagram

Date code are indicated in the product.

General dimension tolerance : ± 0.05
 () dimensions are reference dimensions.

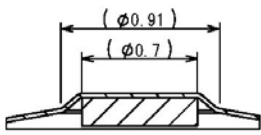
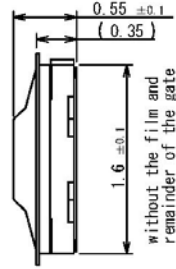
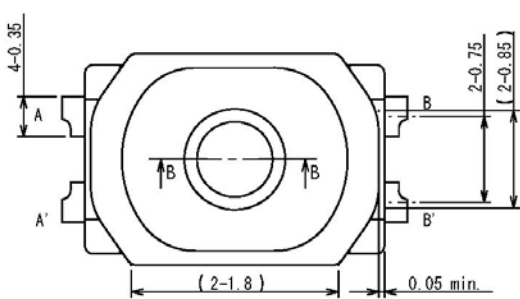

Actuator cross section (Section C-C)

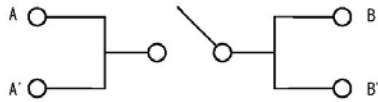

Circuit diagram

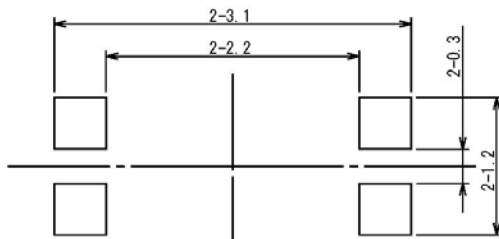
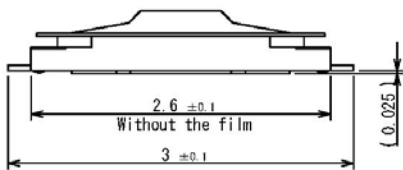

Stencil mask plan

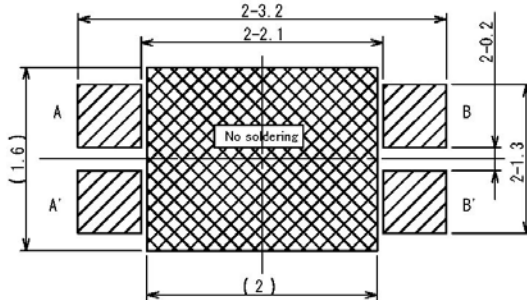
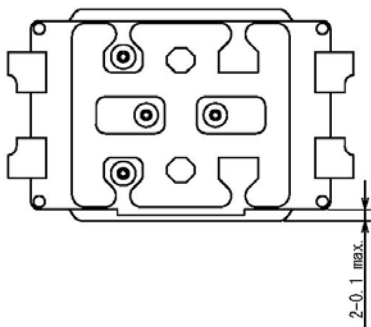

Land pattern plan

Soldering thickness $t=0.08\pm 0.01$

*Soldering failure may occur depending on applied solder amount, so, please consider to use our recommended stencil and land pattern design.

- : Recommended land pattern area
- : No soldering area

- Any land pattern or via holes shall not be provided at area.
- If it's necessary to design land pattern or via holes at area, please apply resin to them to protect their metal part completely.
- If their metal parts are not protected completely, short circuit failure may occur by solder ball.
- Besides, there should be convex/concave by designing additional pattern, it may cause with tilt, influence on solder-ability or flux intrusion after reflow soldering.
- Therefore, please study any influence of additional land pattern or via holes at area in advance.

Classification	SPECIFICATION	Issue No. 20160493
Part Name 2.6mm x 1.6mm SMD Light Touch Switch	Part No. EVPBB4A9BT01	4 / 8

5.2 Mechanical characteristics

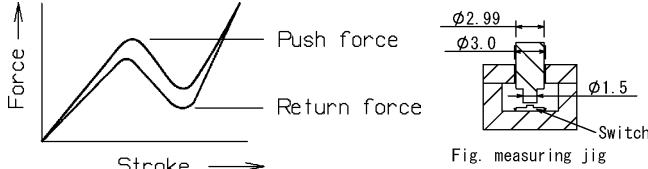
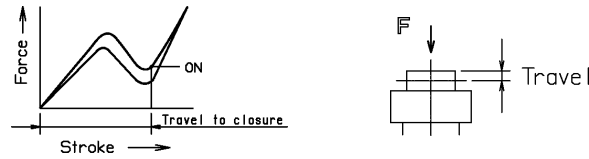
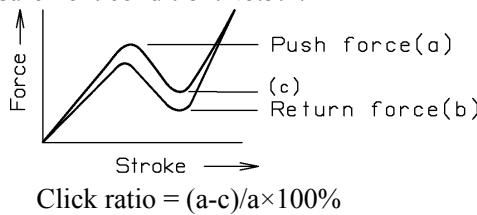
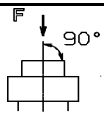
No.	ITEM	TEST CONDITION	PERFORMANCE
5.2.1	Operation force	<p>Operation feeling shall be measured after 3 times pre-operations. Pre-operation condition : 3 times, 1mm/s by 6 N Measurement speed : 0.5 mm/s</p> 	<p>Push force $2.4 \begin{matrix} + \\ - \end{matrix} \begin{matrix} 0.7 \\ 0.7 \end{matrix} \text{ N}$</p> <p>Return force 0.1 N min</p>
5.2.2	Travel to closure		$0.11 \begin{matrix} + \\ - \end{matrix} \begin{matrix} 0.05 \\ 0.05 \end{matrix} \text{ mm}$
5.2.3	Click ratio	<p>Measurement condition: No.5.2.1</p>  <p>Click ratio = $(a-c)/a \times 100\%$</p>	Click ratio 40 % min.
5.2.4	Push strength	<p>50 N for 15 sec.</p> 	No damage (Electrical and mechanical)
5.2.5	Vibration test	<p>1) Amplitude : 1.5 mm 2) Sweep rate : 10-55-10Hz for 1 minute 3) Sweep method : Logarithmic frequency sweep rate 4) Vibration direction : X,Y,Z(3 directions) 5) Time : Each direction 2 hours (Total 6 hours)</p>	No.5.1 and 5.2.1 to 5.2.2 shall be satisfied.
5.2.6	Soldering heat test	<p>Mount the switch on P.W.B by solder paste. 1) Reflow process 2 times. (Refer to section 6.1) 2) Standard conditions after test : 1 hours</p>	Contact resistance 500 mΩ max. Click ratio 35% min. No.5.1.2 to 5.1.4 and No.5.2.1 to 5.2.2 shall be satisfied.
5.2.7	Solderability	<p>After spreading flux, the terminal is immersed in solder with following condition.</p> <p>Solder bar : M705/Sn-3.0Ag-0.5Cu (Senju Metal Industry Co.,Ltd.) Flux : CF-110VH-2A (tamura kaken) Soldering temperture : 260±5 Soldering time : 2±0.5 sec.</p>	95% or more of surface area(Excluding ruptured surface)where is immersed in solder shall be covered by new solder.

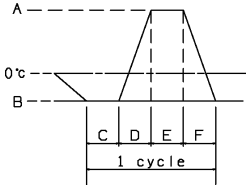
Classification		SPECIFICATION		Issue No.
Part Name 2.6mm x 1.6mm SMD Light Touch Switch		Part No. EVPBB4A9BT01		20160493 5 / 8
5.3 Climatic characteristics				
No.	ITEM	TEST CONDITION	PERFORMANCE	
5.3.1	Cold test	1) Temperature : -40±2 2) Duration of test : 500h 3) Take off a drop water. 4) Standard conditions after test : 1 h	Contact resistance 1000 mΩ max. No.5.1.2 to 5.1.4 and No.5.2.1 to 5.2.2 shall be satisfied.	
5.3.2	Heat test	1) Temperature : 85±2 2) Duration of test : 500h 3) Standard conditions after test : 1 h	Contact resistance 1000 mΩ max. No.5.1.2 to 5.1.4 and No.5.2.1 to 5.2.2 shall be satisfied.	
5.3.3	Heat shock test	1) Test cycles : 20 cycles 2) Standard conditions after test : 1 h  A: +85±2 B: -40±2 C: 1 hour D: 5 minutes max. E: 1 hour F: 5 minutes max.	Contact resistance 1000 mΩ max. No.5.1.2 to 5.1.4 and No.5.2.1 to 5.2.2 shall be satisfied.	
5.3.4	Humidity test	1) Temperature : 60±2 2) Relative humidity : 90 ~ 95 % 3) Duration of test : 500 h 4) Take off a drop water. 5) Standard conditions after test : 1 h	Contact resistance 1000 mΩ max. No.5.1.2 to 5.1.4 and No.5.2.1 to 5.2.2 shall be satisfied.	
5.3.5	Endurance (by spring method)	1) DC 15 V 20 mA Resistance load 2) Operation speed : 2 ~ 3 times/s 3) Push force : Maximum value of operation force 4) Operation number : 500,000 times	Contact resistance 20 Ω max. Bouncing : 30 ms max. Variation rate of operation force shall be within ±30 % to the value before testing No.5.1.2 and 5.2.2 shall be satisfied.	
5.3.6	Withstand H ₂ S	1) Density : 3±1ppm 2) Temperature : 40±2 3) Relative humidity : 80 ~ 85 % 4) Duration of test : 24 h 5) Standard conditions after test : 1 h	Contact resistance 1000 mΩ max. No.5.1.2 to 5.1.4 and No.5.2.1 to 5.2.2 shall be satisfied.	
5.3.7	Water resistance (adhere to IPx7)	1) liquid : Fresh water 2) Temperature : 20±15 (Ambient temperature) 3) Immersion depth : 1m 4) Duration of test : 30min. Water around the switch shall be removed by the moisture absorbing material, then expose the switch in the ambient temperature and humidity for 1 h before checking. * Temperature difference between switch and liquid shall be 5 deg C max.	Water ingress shall be limited enough to prevent deleterious effect to the switch function.	
5.3.8	Dust resistance (adhere to IP6x)	1) Dust : Talc (Type 4) 2) Density : 2kg/m ³ 3) Temperature : 20±15 (Ambient temperature) 4) Relative humidity : 45 ~ 85 % 5) Duration of test : 8 h	No dust ingress to the inside of switch.	

Classification	SPECIFICATION	Issue No. 20160493
Part Name 2.6mm x 1.6mm SMD Light Touch Switch	Part No. EVPBB4A9BT01	6 / 8

6. Prohibitions and precaution for handling

6.1 Reflow soldering condition

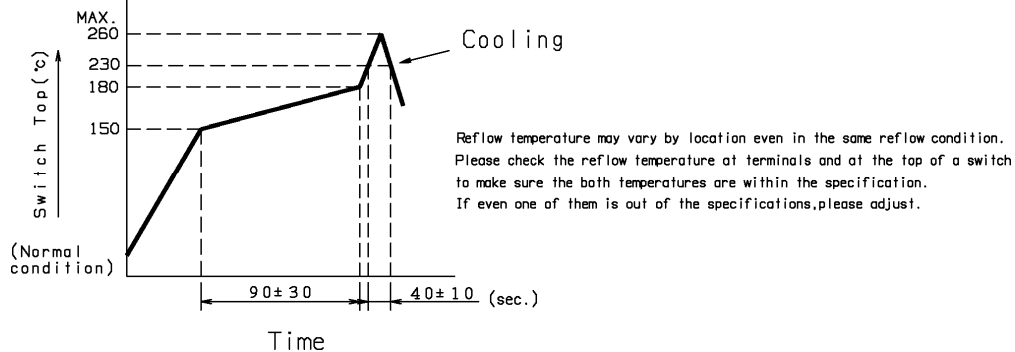

- 1) Two times max. with directing the switch mounting side of P.W.B up.
- 2) Re-soldering by soldering iron shall be allowed under 350 max. 3 sec. max. 1 time only and the tip of iron must not touch to terminals.
Soldering iron for re-soldering have to be 60 W max.

6.2 Design instructions

- 1) Please refer to the land pattern plan Panasonic recommends on the 2nd page.

- 2) Design key top as fig-1.(Recommended operation condition)

As the design of key top may affect operation feeling, please follow the directions stated below.

- We recommend to use harder material such as resin for key top, and we do not recommend softer material such as rubber may affect operation feeling.

However in case if you still would like to use softer material, please consult with us beforehand.

- Considering decentering between switch and key top, the key top shall be always positioned to be able to push the entire top surface of actuator. The switch and the decentering shall be 0.3 mm max..

If you cannot apply our recommended plunger design, please make plungers size bigger than product outline.

- Please design housing and key top not to produce friction to each other to avoid inhibition of operation feeling.

- 3) Please design your knob not to hit the switch film or case even when the switch is fully pushed.

- 4) Please pay attention not to add side force (static or impact) to the push plate of the switch, especially when the switch is being built into the products.(fig-2)

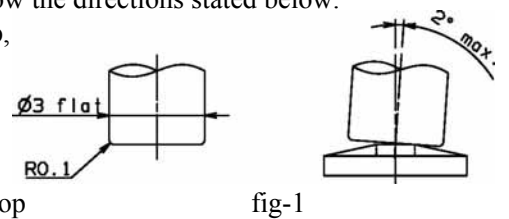

fig-1

6.3 Note

- 1) Please be cautions not to give excessive static load or shock to switches.
- 2) Please be careful not to pile up P.W.B. after switches were soldered.
- 3) Preservation under high temperature and high humidity or corrosive gas should be avoided especially
When you need to preserve for a long period, do not open the carton.
- 4) Avoid pressing the film portion of the product with sharp-edged object.
- 5) Cleaning
 - If flux or solder is scattered on the surface of P.W.B when soldering, characteristics of this product may be damaged.
 - Cleaning after soldering is not allowed. When cleaning is required this switch should be soldered after the cleaning.
- 6) Avoid the use of the switch under pushed ON condition is continued for a long time.
- 7) There is a possibility the flux from solder paste infiltrates into the body if plenty of solder paste was applied by switch on the P.W.B.
So we recommend to use our proposed land design in order to prevent above problem.
Also please avoid putting additional land by the switch on the P.W.B.
- 8) Please don't apply any coating material to the switch after reflow soldering.
- 9) Please be careful not to apply the load sideways to avoid film bending when the switches are soldered.

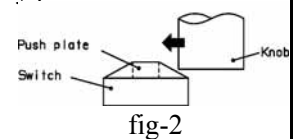
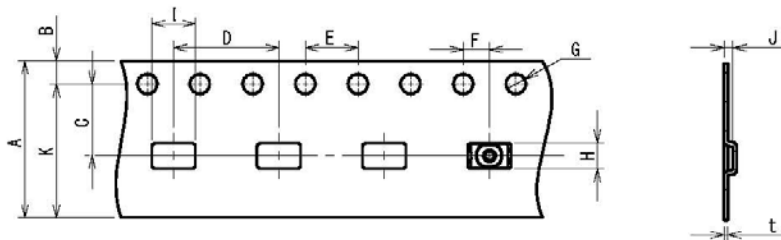

fig-2

Classification	SPECIFICATION	Issue No. 20160493
Part Name 2.6mm x 1.6mm SMD Light Touch Switch	Part No. EVPBB4A9BT01	7 / 8

7. Packing specification

Carrier tape



Unit:mm

A	B	C	D	E	F	G	H	I	J	K	t
± 0.3 12	± 0.1 1.75	± 0.1 5.5	± 0.1 8	± 0.1 4	± 0.1 2	± 0.3 1.5	± 0.2 1.95	± 0.2 3.3	± 0.2 0.7	(10.25)	$\begin{matrix} +0.15 \\ -0.1 \end{matrix}$ 0.3

Taping condition : Lack of products in the middle of taping should be one MAX, but total quantity specified in the specifications should be secured.

Peeling off strength of top tape : It should be within 0.2N to 1.0N at 165 degree in peeling off angle.

Joint of carrier tape : One joint per one reel may exist.

Reel (10000pcs./reel)

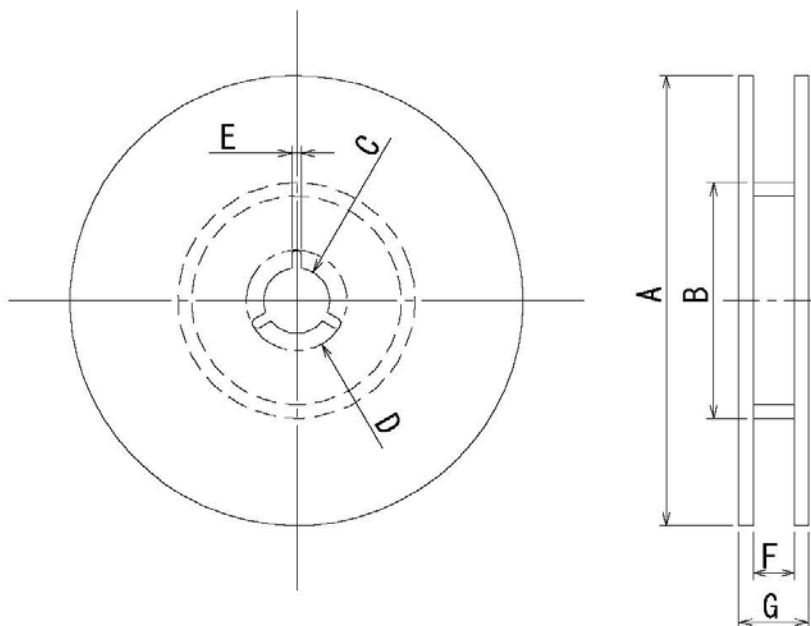

Unit:mm

A	B	C	D	E	F	G
± 2 ϕ 380	± 1 ϕ 80	± 0.5 ϕ 13	± 1 ϕ 21	± 0.5 2	± 1 13.5	± 1 17.5

Classification	Issue No. 20160493
SPECIFICATION	
Part Name 2.6mm x 1.6mm SMD Light Touch Switch	Part No. EVPBB4A9BT01 8 / 8
<p><Prohibitions and precaution for handling></p> <p>[Prohibited items on fire and smoking]</p> <ul style="list-style-type: none"> · Absolutely avoid use of a product beyond its rated range because doing so may cause a fire. If misuse or abnormal use may result under conditions in which the product is used out of its rated range, take proper measures such as current interruption using a protective circuit. · The grade of nonflammability for resin used in product is "94HB, " which is based on UL94 Standards (flammability test for plastic materials). Prohibit use in a location where a spreading fire may be generated or prepare against a spreading fire. <p>[For use in equipment for which safety is requested]</p> <ul style="list-style-type: none"> · Although care is taken to ensure product quality, inferior characteristics, short circuits, and open circuits are some problems that might be generated. To design an equipment which places maximum emphasis on safety, review the effect of any single fault of a product in advance and perform virtually fail-safe design to ensure maximum safety by: <ul style="list-style-type: none"> · Preparing a protective circuit or a protective device to improve system safety, and equipment. · Preparing a redundant circuit to improve system safety so that the single fault of a product does not cause a dangerous situation. <p>[Attentions required for storage condition]</p> <ul style="list-style-type: none"> · When this product is to be stored in the following circumstances and conditions, it may affect on the performance deteriorations and solderability etc., avoid storing in the following conditions. <ol style="list-style-type: none"> (1) A place where the temperature is -10 max., +40 min. and the humidity is 85% min. (2) In the corrosive gas atmosphere. (3) Long-term storage for 6 months min. (4) A place where the product is exposed to direct sunlight. · Store in packed condition so that the load stress is not applied. · Please use this product as soon as possible, our recommendation is within 3 months and the limitation is 6 months. · If any remainder left after packing is opened, store it with proper moistureproofing and gasproofing, etc., 	

单击下面可查看定价，库存，交付和生命周期等信息

[>>Panasonic\(松下\)](#)