



DESCRIPTION:

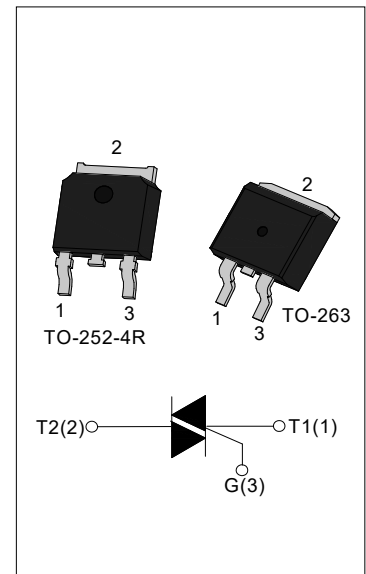
With high ability to withstand the shock loading of large current, JST08 series triacs provide high dv/dt rate with strong resistance to electromagnetic interface. With high commutation performances, 3 quadrants products especially recommended for use on inductive load.

Package TO-263 and TO-252-4R are RoHS compliant.

(2011/65/EU)

MAIN FEATURES

Symbol	Value	Unit
$I_{T(RMS)}$	8	A
V_{DRM} / V_{RRM}	600/800/1200	V



ABSOLUTE MAXIMUM RATINGS

Parameter		Symbol	Value	Unit
Storage junction temperature range		T_{stg}	-40 - 150	°C
Operating junction temperature range		T_j	-40 - 125	°C
Repetitive peak off-state voltage ($T_j=25^\circ\text{C}$)		V_{DRM}	600/800/1200	V
Repetitive peak reverse voltage ($T_j=25^\circ\text{C}$)		V_{RRM}	600/800/1200	V
RMS on-state current	TO-263 ($T_C=90^\circ\text{C}$)	$I_{T(RMS)}$	8	A
	TO-252-4R ($T_C=100^\circ\text{C}$)			
Non repetitive surge peak on-state current (full cycle, $F=50\text{Hz}$)		I_{TSM}	80	A
I^2t value for fusing ($t_p=10\text{ms}$)		I^2t	32	A^2s
Critical rate of rise of on-state current ($I_G=2 \times I_{GT}$)		di/dt	50	$\text{A}/\mu\text{s}$
Peak gate current		I_{GM}	4	A
Average gate power dissipation		$P_{G(AV)}$	1	W
Peak gate power		P_{GM}	5	W

ELECTRICAL CHARACTERISTICS ($T_j=25^{\circ}\text{C}$ unless otherwise specified)

3 Quadrants

Symbol	Test Condition	Quadrant		Value				Unit
				TW	SW	CW	BW	
I_{GT}	$V_D=12\text{V } R_L=33\Omega$	I - II -III	MAX	5	10	35	50	mA
V_{GT}		I - II -III	MAX	1.5				V
V_{GD}	$V_D=V_{DRM} T_j=125^{\circ}\text{C}$ $R_L=3.3\text{K}\Omega$	I - II -III	MIN	0.2				V
I_L	$I_G=1.2I_{GT}$	I -III	MAX	20	25	50	70	mA
		II		25	35	70	90	
I_H	$I_{TM}=100\text{mA}$		MAX	15	20	40	60	mA
dV/dt	$V_D=2/3V_{DRM}$ Gate Open $T_j=125^{\circ}\text{C}$		MIN	50	200	500	1000	V/ μs

4 Quadrants

Symbol	Test Condition	Quadrant		Value		Unit
				C	B	
I_{GT}	$V_D=12\text{V } R_L=33\Omega$	I - II -III	MAX	25	50	mA
		IV		50	70	
V_{GT}		ALL	MAX	1.5		V
V_{GD}	$V_D=V_{DRM} T_j=125^{\circ}\text{C}$ $R_L=3.3\text{K}\Omega$	ALL	MIN	0.2		V
I_L	$I_G=1.2I_{GT}$	I -III-IV	MAX	50	70	mA
		II		70	90	
I_H	$I_{TM}=200\text{mA}$		MAX	40	60	mA
dV/dt	$V_D=2/3V_{DRM}$ Gate Open $T_j=125^{\circ}\text{C}$		MIN	200	500	V/ μs

STATIC CHARACTERISTICS

Symbol	Parameter		Value(MAX)	Unit
V_{TM}	$I_{TM}=11\text{A } t_p=380\mu\text{s}$	$T_j=25^{\circ}\text{C}$	1.5	V
V_{TO}	Threshold voltage	$T_j=125^{\circ}\text{C}$	0.95	V
R_d	Dynamic resistance	$T_j=125^{\circ}\text{C}$	40	m Ω
I_{DRM}	$V_D=V_{DRM} V_R=V_{RRM}$	$T_j=25^{\circ}\text{C}$	5	μA
I_{RRM}		$T_j=125^{\circ}\text{C}$	1	mA

THERMAL RESISTANCES

Symbol	Parameter	Value	Unit
R _{th(j-c)}	junction to case(AC)	TO-263	3.0
		TO-252-4R	2.1
R _{th(j-a)}	junction to ambient	TO-263	45
		TO-252-4R	70

ORDERING INFORMATION

J JieJie Microelectronics Co.,Ltd	ST Triacs I _{T(RMS)} :8A	08 E:TO-263 K:TO-252-4R 600:V _{DRM} /V _{RRM} ≥600V 800:V _{DRM} /V _{RRM} ≥800V 1200:V _{DRM} /V _{RRM} ≥1200V	K	-800	CW	-/ Blank: Tube TR: Tape & Reel TW: I _G T1-3≤5mA SW: I _G T1-3≤10mA CW: I _G T1-3≤35mA BW: I _G T1-3≤50mA C: I _G T1-3≤25mA I _G T4≤50mA B: I _G T1-3≤50mA I _G T4≤70mA
---	--	--	----------	-------------	-----------	--

MARKING

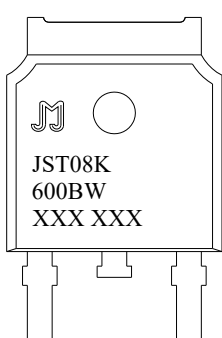
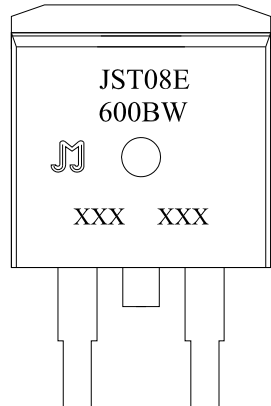
	
<p>XXX XXX</p> <p>Year _____ Production Code _____ Month _____ Code _____</p>	

FIG.1: Maximum power dissipation versus RMS on-state current

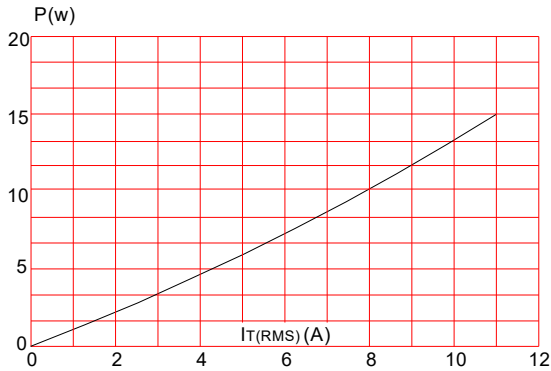


FIG.2: RMS on-state current versus case temperature

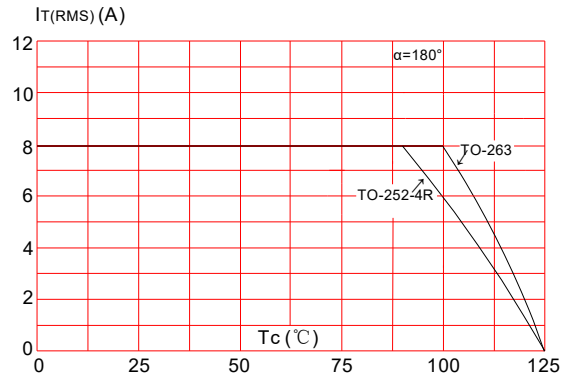


FIG.3: RMS on-state current versus ambient temperature (printed circuit board FR4, copper thickness:35μm)(full cycle)

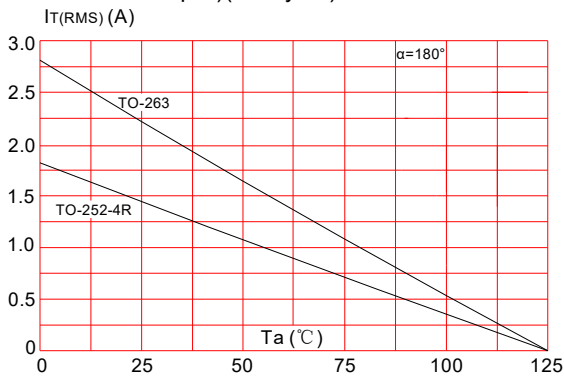


FIG.4: Surge peak on-state current versus number of cycles

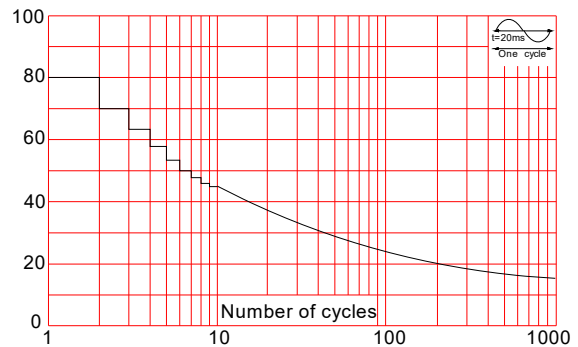


FIG.5: On-state characteristics (maximum values)

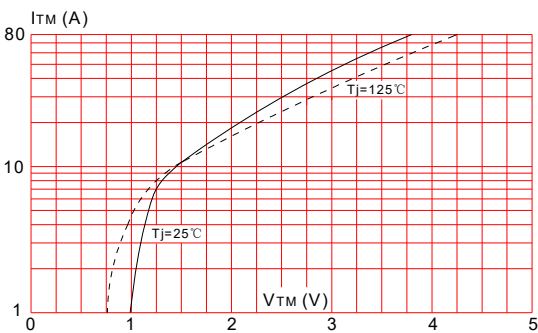


FIG.6: Non-repetitive surge peak on-state current for a sinusoidal pulse with width tp<20ms, and corresponding value of I²t (di/dt <50A/μs)

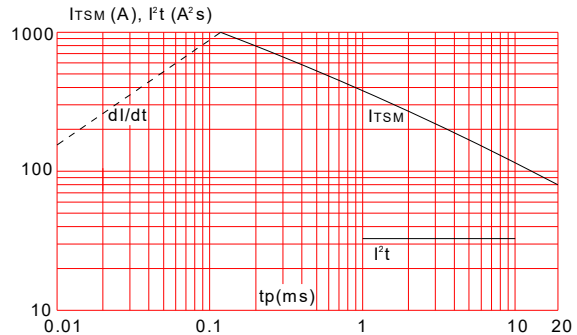
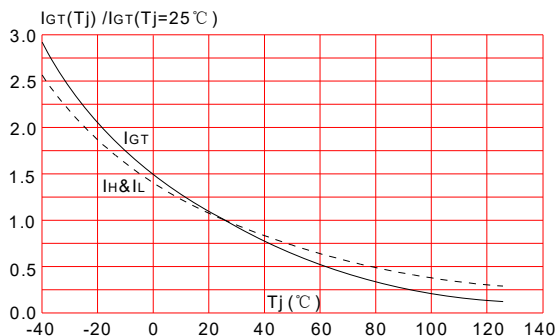
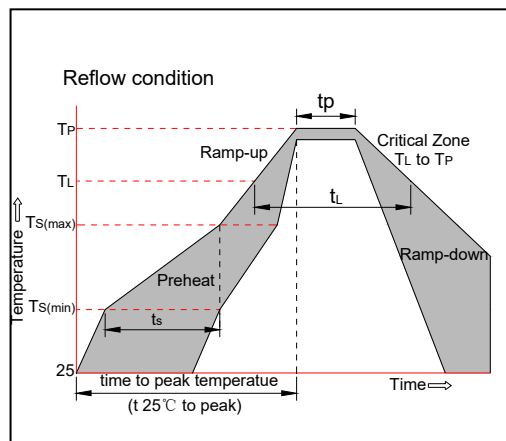


FIG.7: Relative variations of gate trigger current, holding current and latching current versus junction temperature



SOLDERING PARAMETERS

Reflow Condition		Pb-Free assembly (see figure at right)
Pre Heat	-Temperature Min (T _{s(min)})	+150°C
	-Temperature Max(T _{s(max)})	+200°C
	-Time (Min to Max) (ts)	60-180 secs.
Average ramp up rate (Liquidus Temp (T _L)to peak)		3°C/sec. Max
T _{s(max)} to T _L - Ramp-up Rate		3°C/sec. Max
Reflow	-Temperature(T _L) (Liquidus)	+217°C
	-Temperature(t _L)	60-150 secs.
Peak Temp (T _p)		+260(+0/-5)°C
Time within 5°C of actual Peak Temp (t _p)		20-40secs.
Ramp-down Rate		6°C/sec. Max
Time 25°C to Peak Temp (T _p)		8 min. Max
Do not exceed		+260°C



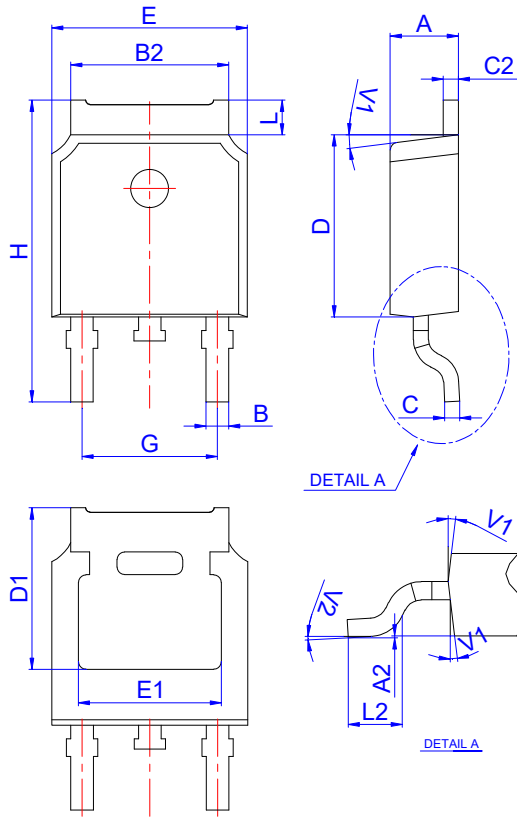
ORDERING INFORMATION

Order code	Voltage V_{DRM}/V_{RRM} (V)	IGT(mA)		Package	Base qty. (pcs)	Delivery mode
		I - II -III				
JST08K-600(800/1200)TW	600/800/1200	5		TO-252-4R	80	Tube
JST08K-600(800/1200)SW	600/800/1200	10				
JST08K-600(800/1200)CW	600/800/1200	35				
JST08K-600(800/1200)BW	600/800/1200	50				
JST08K-600(800/1200)TW	600/800/1200	5			2,500	Tape & Reel
JST08K-600(800/1200)SW	600/800/1200	10				
JST08K-600(800/1200)CW	600/800/1200	35				
JST08K-600(800/1200)BW	600/800/1200	50				
JST08E-600(800/1200)TW	600/800/1200	5		TO-263	50	Tube
JST08E-600(800/1200)SW	600/800/1200	10				
JST08E-600(800/1200)CW	600/800/1200	35				
JST08E-600(800/1200)BW	600/800/1200	50				
JST08E-600(800/1200)TW	600/800/1200	5			800	Tape & Reel
JST08E-600(800/1200)SW	600/800/1200	10				
JST08E-600(800/1200)CW	600/800/1200	35				
JST08E-600(800/1200)BW	600/800/1200	50				
Order code	Voltage V_{DRM}/V_{RRM} (V)	IGT(mA)		Package	Base qty. (pcs)	Delivery mode
		I - II -III	IV			
JST08K-600(800/1200)B	600/800/1200	50	70	TO-252-4R	80	Tube
JST08K-600(800/1200)C	600/800/1200	25	50		2,500	Tape & Reel
JST08K-600(800/1200)B	600/800/1200	50	70	TO-263	50	Tube
JST08K-600(800/1200)C	600/800/1200	25	50		800	Tape & Reel

Document Revision History

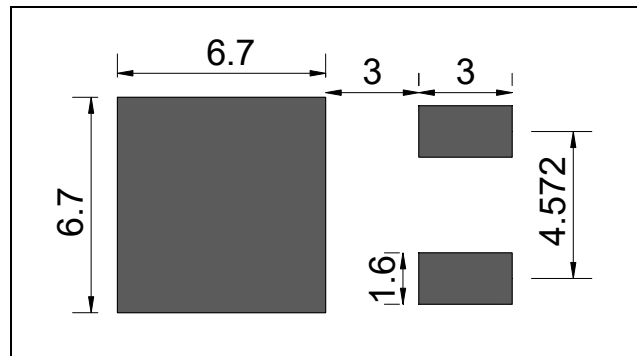
Date	Revision	Changes
March 29, 2021	9	Last update
Feb 21,2022	10	Add Vto&Rd

PACKAGE MECHANICAL DATA

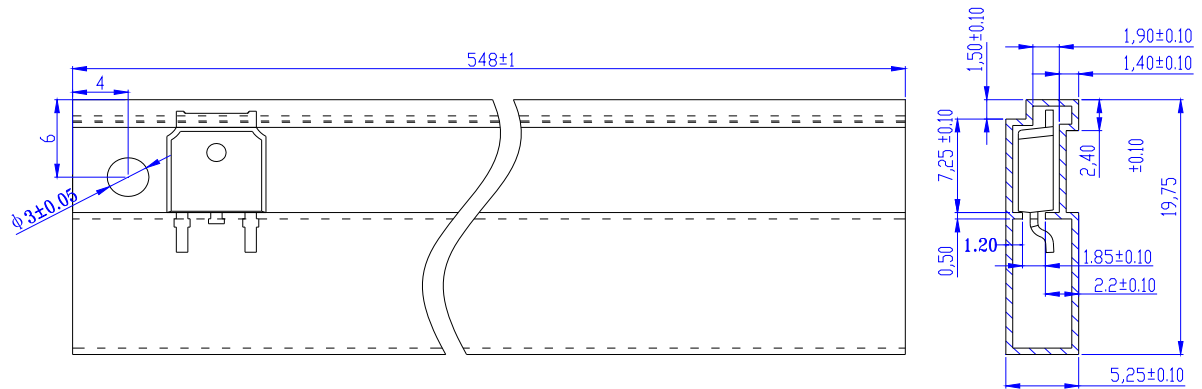


Ref.	Dimensions					
	Millimeters			Inches		
	Min.	Typ.	Max.	Min.	Typ.	Max.
A	2.10		2.50	0.083		0.098
A2	0		0.10	0		0.004
B	0.66		0.86	0.026		0.034
B2	5.18		5.48	0.202		0.216
C	0.40		0.60	0.016		0.024
C2	0.44		0.58	0.017		0.023
D	5.90		6.30	0.232		0.248
D1	5.10		5.50	0.201		0.217
E	6.40		6.80	0.252		0.268
E1	4.63			0.182		
G	4.47		4.67	0.176		0.184
H	9.50		10.70	0.374		0.421
L	1.00		1.30	0.039		0.051
L2	1.35		1.75	0.053		0.069
V1		7°			7°	
V2	0°		6°	0°		6°

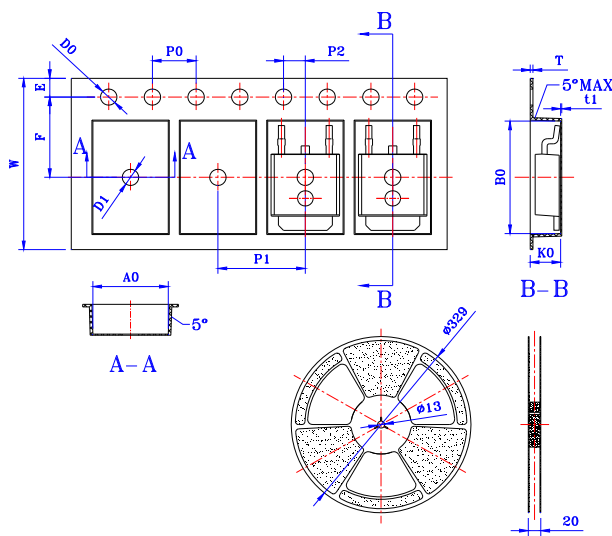
FOOTPRINT-TO-252-4R (dimensions in mm)



DELIVERY MODE



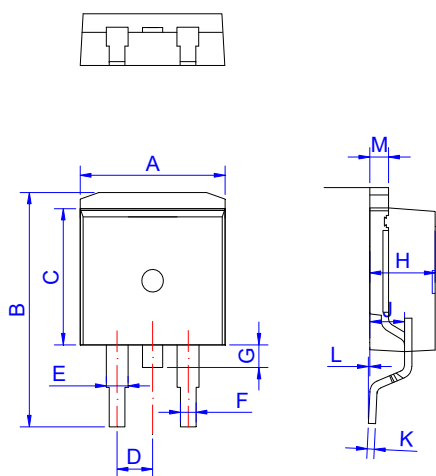
PACKAGE	OUTLINE	TUBE (PCS)	INNER BOX (PCS)	PER CARTON
TO-252-4R	TUBE	80	4,000	20,000



Ref.	Dimensions					
	Millimeters			Inches		
	Min.	Typ.	Max.	Min.	Typ.	Max.
W	15.90	16.00	16.10	0.626	0.630	0.634
E	1.65	1.75	1.85	0.065	0.069	0.073
F	7.40	7.50	7.60	0.291	0.295	0.299
D0	1.40	1.50	1.60	0.055	0.059	0.063
D1	1.40	1.50	1.60	0.055	0.059	0.063
P0	3.90	4.00	4.10	0.154	0.157	0.161
P1	7.90	8.00	8.10	0.311	0.315	0.319
P2	1.90	2.00	2.10	0.075	0.079	0.083
10P0	39.80	40.00	40.20	1.567	1.575	1.583
A0	6.85	6.90	7.00	0.270	0.272	0.276
B0	10.45	10.50	10.60	0.411	0.413	0.417
K0	2.68	2.78	2.88	0.106	0.109	0.113
T	0.24	-	0.27	0.009	-	0.011
t1	0.10	-	-	0.004	-	-

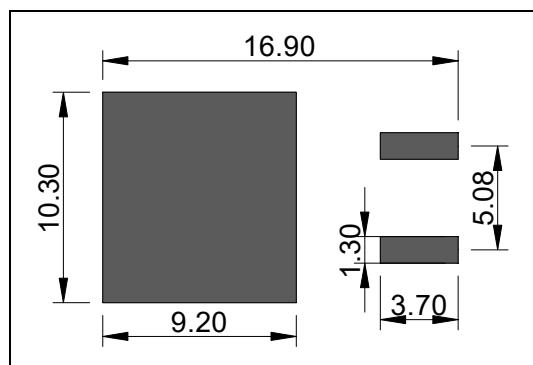
PACKAGE	OUTLINE	REEL (PCS)	PER CARTON (PCS)	TAPE & REEL
TO-252-4R	TAPING	2,500	25,000	13 inch

PACKAGE MECHANICAL DATA

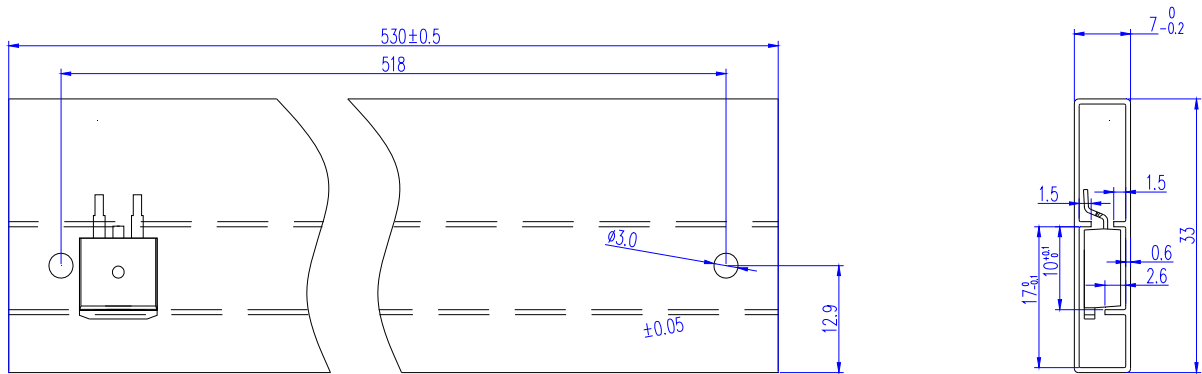


Ref.	Dimensions					
	Millimeters			Inches		
	Min.	Typ.	Max.	Min.	Typ.	Max.
A	9.90		10.20	0.390		0.402
B	14.70		15.80	0.579		0.622
C	9.40		9.60	0.37		0.378
D	2.40		2.70	0.094		0.106
E	1.20		1.50	0.047		0.059
F	0.75		0.85	0.029		0.033
G	1.00		1.50	0.039		0.059
H	4.40		4.70	0.173		0.185
J	2.30		2.70	0.091		0.106
K	0.38		0.55	0.015		0.022
L	0	0.10	0.25	0	0.004	0.010
M	1.25		1.35	0.049		0.053

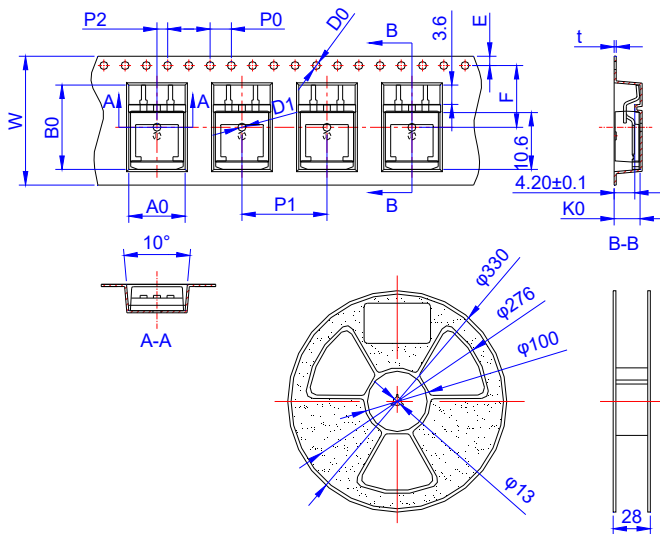
FOOTPRINT-TO-263 (dimensions in mm)



DELIVERY MODE



PACKAGE	OUTLINE	TUBE (PCS)	INNER BOX (PCS)	PER CARTON	INNER BOX DIMENSION (cm)	CARTON DIMENSION (cm)
TO-263	TUBE	50	1,000	5,000	55*14*4	57*26.6*16




Ref.	Dimensions					
	Millimeters			Inches		
	Min.	Typ.	Max.	Min.	Typ.	Max.
W	23.70	24.00	24.30	0.933	0.945	0.957
E	1.65	1.75	1.85	0.065	0.069	0.073
F	11.40	11.50	11.60	0.449	0.453	0.457
D0	-	1.50	1.60	-	0.059	0.063
D1	-	1.50	1.60	-	0.059	0.063
P0	3.90	4.00	4.10	0.154	0.157	0.161
P1	15.90	16.00	16.10	0.626	0.630	0.634
P2	1.90	2.00	2.10	0.075	0.079	0.083
A0	10.80	10.90	11.00	0.425	0.429	0.433
B0	16.20	16.30	16.40	0.638	0.642	0.646
K0	4.80	4.90	5.00	0.189	0.193	0.197
t	0.35	0.40	0.45	0.014	0.016	0.018

PACKAGE	OUTLINE	REEL (PCS)	PER CARTON (PCS)	TAPE & REEL	INNER BOX DIMENSION (cm)	CARTON DIMENSION (cm)
TO-263	TAPING	800	4,000	13 inch	35*33.5*3.5	38*35.5*21



Information furnished in this document is believed to be accurate and reliable. However, Jiangsu JieJie Microelectronics Co.,Ltd assumes no responsibility for the consequences of use without consideration for such information nor use beyond it. Information mentioned in this document is subject to change without notice, apart from that when an agreement is signed, Jiangsu JieJie complies with the agreement. Products and information provided in this document have no infringement of patents. Jiangsu JieJie assumes no responsibility for any infringement of other rights of third parties which may result from the use of such products and information. This document supersedes and replaces all information previously supplied.

 is a registered trademark of Jiangsu JieJie Microelectronics Co.,Ltd.

Copyright ©2022 Jiangsu JieJie Microelectronics Co.,Ltd. Printed All rights reserved.

单击下面可查看定价，库存，交付和生命周期等信息

[>>JW\(捷捷微\)](#)