

 XIAMEN DEXIAN ELECTRONICS TECHNOLOGY CO., LTD	PRODUCT SPECIFICATION	ISSUED DATE:	2023/02/27
		REV. NO.:	A05
	SERIES: DET	DOC. NO.:	DX-PSI-001
		PAGE	PAGE 1 OF 9

制定 PREPARED BY		审核 CHECKED BY		批准 APPROVED BY	
-------------------	---	------------------	---	-------------------	---

1. 适用范围/SCOPE

本产品适用于各种电子机器内的电路中起过电流保护作用。

This product is suitable for various kinds of electronic machines to work for over current protection.

产品部件号为: 型号 额定电流 额定电压 包装方式
 Construction of part no: type rated current rated voltage packing mode
 例如/ For Example: DET 0100 H A

* 额定电压 Rated voltage: L-125V H - 250V H₁ - 300V H₂ - 400V

* 包装方式/ Packaging mode: A - 编带包装 Ammo-pack; B - 散装 Bulk.

产品部件号/ PART NUMBER

产品部件号 PART NUMBER	型号规格 MODEL DETAIL	产品部件号 PART NUMBER	型号规格 MODEL DETAIL
DET-0100L/H/H ₁ /H ₂ A/B	DET T100mA 125V/250V/300V/400V	DET-013L/H/H ₁ /H ₂ A/B	DET T1.25A 125V/250V/300V/400V
DET-0125L/H/H ₁ /H ₂ A/B	DET T125mA 125V/250V/300V/400V	DET-016L/H/H ₁ /H ₂ A/B	DET T1.6A 125V/250V/300V/400V
DET-0160L/H/H ₁ /H ₂ A/B	DET T160mA 125V/250V/300V/400V	DET-020L/H/H ₁ /H ₂ A/B	DET T2A 125V/250V/300V/400V
DET-0200L/H/H ₁ /H ₂ A/B	DET T200mA 125V/250V/300V/400V	DET-025L/H/H ₁ /H ₂ A/B	DET T2.5A 125V/250V/300V/400V
DET-0250L/H/H ₁ /H ₂ A/B	DET T250mA 125V/250V/300V/400V	DET-032L/H/H ₁ /H ₂ A/B	DET T3.15A 125V/250V/300V/400V
DET-0315L/H/H ₁ /H ₂ A/B	DET T315mA 125V/250V/300V/400V	DET-040L/H/H ₁ /H ₂ A/B	DET T4A 125V/250V/300V/400V
DET-0400L/H/H ₁ /H ₂ A/B	DET T400mA 125V/250V/300V/400V	DET-050L/H/H ₁ /H ₂ A/B	DET T5A 125V/250V/300V/400V
DET-0500L/H/H ₁ /H ₂ A/B	DET T500mA 125V/250V/300V/400V	DET-063L/H/H ₁ /H ₂ A/B	DET T6.3A 125V/ 250V/300V/400V
DET-0630L/H/H ₁ /H ₂ A/B	DET T630mA 125V/250V/300V/400V	DET-080L/H/H ₁ /H ₂ A/B	DET T8A 125V/250V/300V/400V
DET-0800L/H/H ₁ /H ₂ A/B	DET T800mA 125V/250V/300V/400V	DET-100L/H/H ₁ /H ₂ A/B	DET T10A 125V/ 250V/300V/400V
DET-010L/H/H ₁ /H ₂ A/B	DET T1A 125V/250V/300V/400V	/	/

型号规格: 型号 特性符号 额定电流 额定电压
 MODEL DETAIL: Type Characteristic Symbol Rated Current Rated Voltage
 例如/ Example: DET T 1A 250V

*特性符号/ Characteristic Symbol: T - 慢断型/ Time-Lag.

2. 相关标准及认证情况/ APPLICABLE STANDARDS & APPROVED DETAILS

2.1 执行标准 Standards: IEC60127-1、IEC60127-3、GB/T 9364.1、GB/T 9364.3

2.2 认证情况/ APPROVED DETAILS

认证 Certification	额定电压 Rated Voltage	认证范围 Scope of Certification	证书编号 Certification No.
UR/cUR	125V/250V/300V/400V	100mA~8A	E500879
CCC 自我声明	250V	1A~6.3A	2020970207000071
CQC	250V	1A~6.3A	CQC22107340884
	300V	3.15A/4A	CQC22012371032
TUV	250V/300V/400V	200mA~6.3A	R50415458
PSE	250V/300V	1A~5A	PSE19021427
		6.3A	PSE19021426
KC	250V	1A~2.5A	RU05059-18001
		3.15A~6.3A	RU05059-18002
VDE	250V	1A~6.3A	40052411

CCC 自我声明符合认证二维码



2020970207000071

 XIAMEN DEXIAN ELECTRONICS TECHNOLOGY CO., LTD	PRODUCT SPECIFICATION	ISSUED DATE:	2023/02/27
		REV. NO.:	A05
	SERIES: DET	DOC. NO.:	DX-PSI-001
		PAGE	PAGE 2 OF 9

3. 公司地址/ ADDRESS

厦门火炬高新区(翔安)产业区翔安西路 8057 号第五层。

Fifth floor, NO.8057 West Xiang'An Rd, Torch High-tech industrial District, Xiang'An, Xiamen.

4. 结构及尺寸 Structure and Size (unit: mm)

散装 Bulk(L≤5mm):

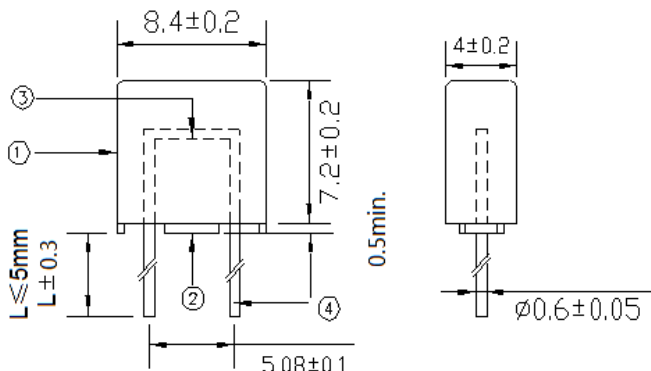

编带包装 Ammo-pack:

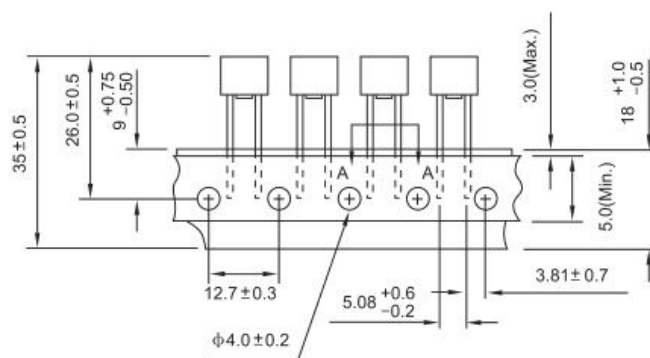

4.1 原材料明细 Material Details

编号 No.	零件名称 Part Name	材质 Material	备注/ REMARK
①	外壳 Case	工程塑料/ Thermoplastic	黑色/ Black
②	基座 Base	工程塑料/ Thermoplastic	黑色/ Black
③	熔丝 Fuse element	玻璃纤维线+金属丝/ Glass Fiber+ Metal Wire	/
④	引线 Lead wire	镀锡铜线 Tinned copper wire	/

4.2 方形塑料帽/ Square THERMOPLASTIC CAP

方形塑料帽无破裂、缺损或污染等现象。

Square Thermoplastic Cap shall have no defects such as crack, injury and contamination.

4.3 塑料件阻燃性能/ FLAMMABILITY CIASSIFICATION: UL 94-V0.

5. 机械特性/ MECHANICAL PERFORMANCES

保险丝应能承受下列二项试验。Fuse shall withstand the following two tests.

5.1 拉力试验/ TENSILE TEST

将保险丝保持在一个固定的位置，沿引线方向施加 10N 的拉力，引线、方形塑料帽不能松动并且方形塑料帽不应破裂。When fuse is fixed and the tensile force 10N is applied in a direction to lead, no looseness of leads and square thermoplastic cap or damage of square thermoplastic cap shall occur.

5.2 推力试验/ THRUST TEST

将保险丝保持在一个固定的位置，沿引线方向施加 2N 的推力，引线、方形塑料不能松动并且方形塑料不应破裂。When fuse is fixed and the thrust 2N is applied in a direction to lead, no looseness of leads and square thermoplastic cap or damage of square thermoplastic cap shall occur.

6. 电气特性/ ELECTRICAL PERFORMANCES

6.1 测试条件/ TEST CONDITIONS

A 全部测试条件都应在环境温度 24℃±3℃条件下进行，在此期间温度变化不允许达到+5℃和到极限范围。

All electrical tests are conducted at a ambient temperature of 24±3℃. The ambient temperature is not allowed to vary more than 5℃ during the test, and must be within these limits.

B 每个保险丝支架，水平安装在非导电的胶木测试板上，以便被测的保险丝在测试板上能保持水平。

Each fuse-holder is to be mounted horizontally on a test board of non-conducting bakelite, so that each fuse

 XIAMEN DEXIAN ELECTRONICS TECHNOLOGY CO., LTD	PRODUCT SPECIFICATION	ISSUED DATE:	2023/02/27
		REV. NO.:	A05
	SERIES: DET	DOC. NO.:	DX-PSI-001
		PAGE	PAGE 3 OF 9

under test is held in a horizontal position above the board.

6.2 电压降、平均 I²T 值(供参考)、最大持续功耗/ VOLTAGE DROP, AVERAGE I²T VALUE(FOR REFERENCE ONLY) And MAXIMUM SUSTAINED DISSIPATION

额定电 流 Rated Current	1.0I _n 最大电压降 1.0I _n VOLTAGE DROP Max.(mV)	平均 I ² T 值/ Average I ² T Value(A ² .se c.)	1.5I _n 最大持续功耗 1.5I _n Maximum Sustained Dissipation (mW)	额定电流 Rated Current	1.0I _n 最大电压降 1.0I _n VOLTAGE DROP Max.(mV)	平均 I ² T 值/ Average I ² T Value(A ² .sec.)	1.5I _n 最大持续功耗 1.5I _n Maximum Sustained Dissipation (mW)
100mA	350	0.02623	170	1.25A	130	14.88	600
125mA	300	0.04499	180	1.6A	120	26.82	730
160mA	280	0.1267	190	2A	100	48.51	870
200mA	260	0.1822	200	2.5A	100	68.75	1000
250mA	240	0.4365	220	3.15A	100	106.2	1200
315mA	220	0.5372	250	4A	100	128.3	1400
400mA	200	0.7735	280	5A	100	190.0	1680
500mA	190	1.421	310	6.3A	100	309.5	2000
630mA	180	2.769	360	8A	100	327.1	2500
800mA	160	4.121	430	10A	100	439.2	3000
1A	140	8.885	500			/	

6.3 负载能力测试/ CURRENT-CARRYING CAPACITY TEST

当保险丝通以 150%倍额定电流的条件下进行测试时, 在 1 小时内电路不应断开, 保险丝不被电流熔断, 方形塑料帽不破裂、脱落。A fuse shall carry 150% of rated current for 1 hour or more, and the circuit shall not be opened. While the fuse is carrying this current, no open circuit, melt fusible element, and square thermoplastic cap shall not be charred or ruptured in any manner.

6.4 预飞弧时间-电流特性/ PRE-ARCING TIME-CURRENT CHARACTERISTICS

当保险丝通以下表规定的电流时, 其熔断时间必须符合下表的要求, 且方形塑料帽不能飞脱、损坏。When the current in the following table is passing the fuse, its opening time must be in accordance with the requirements in the following table, that is, the pre-arcing time. Moreover, there shall be not damaged or shattered of the square thermoplastic cap.

额定电流 Rated Current	2.1 I _n	2.75 I _n		4 I _n		10 I _n	
	Max.	Min.	Max.	Min.	Max.	Min.	Max.
100mA~10A	2min.	400ms	10s	150ms	3s	20ms	150ms

6.5 分断能力/ BREAKING CAPACITY

保险丝的分断能力应能达到下表规定的相应的各种安全认证的分断能力要求。保险丝分断电路后, 方形塑料帽不应飞脱、损坏。The breaking capacity should reach the rated breaking current given in the following table. And after this test, there shall be not damaged or shattered of the square thermoplastic cap.

额定电压 RATED VOLTAGE	分断电流/ BREAKING CURRENT				
	KC	CCC/CQC	UR/CUR	TUV	PSE
125V _{ac}	/	/	100A	/	/
250V _{ac}	35A(1A~3.15A) or 10I _n (4A~6.3A)			35A(200mA~3.15A) or 10I _n (4A~6.3A)	100A
300V _{ac}					
400V _{ac}	/	/		/	



XIAMEN DEXIAN ELECTRONICS
TECHNOLOGY CO., LTD

PRODUCT SPECIFICATION

SERIES: DET

ISSUED DATE:

2023/02/27

REV. NO.:

A05

DOC. NO.:

DX-PSI-001

PAGE

PAGE 4 OF 9

6.6 平均 I-T 特性曲线图(仅供参考)/ THE AVERAGE I-T CHARACTERISTICS CURVE(FOR REFERENCE ONLY)

DETRoHS 平均I-T曲线图(仅供参考)
DETRoHS AVERAGE I-T CHARACTERISTICS CURVE(FOR REFERENCE ONLY)

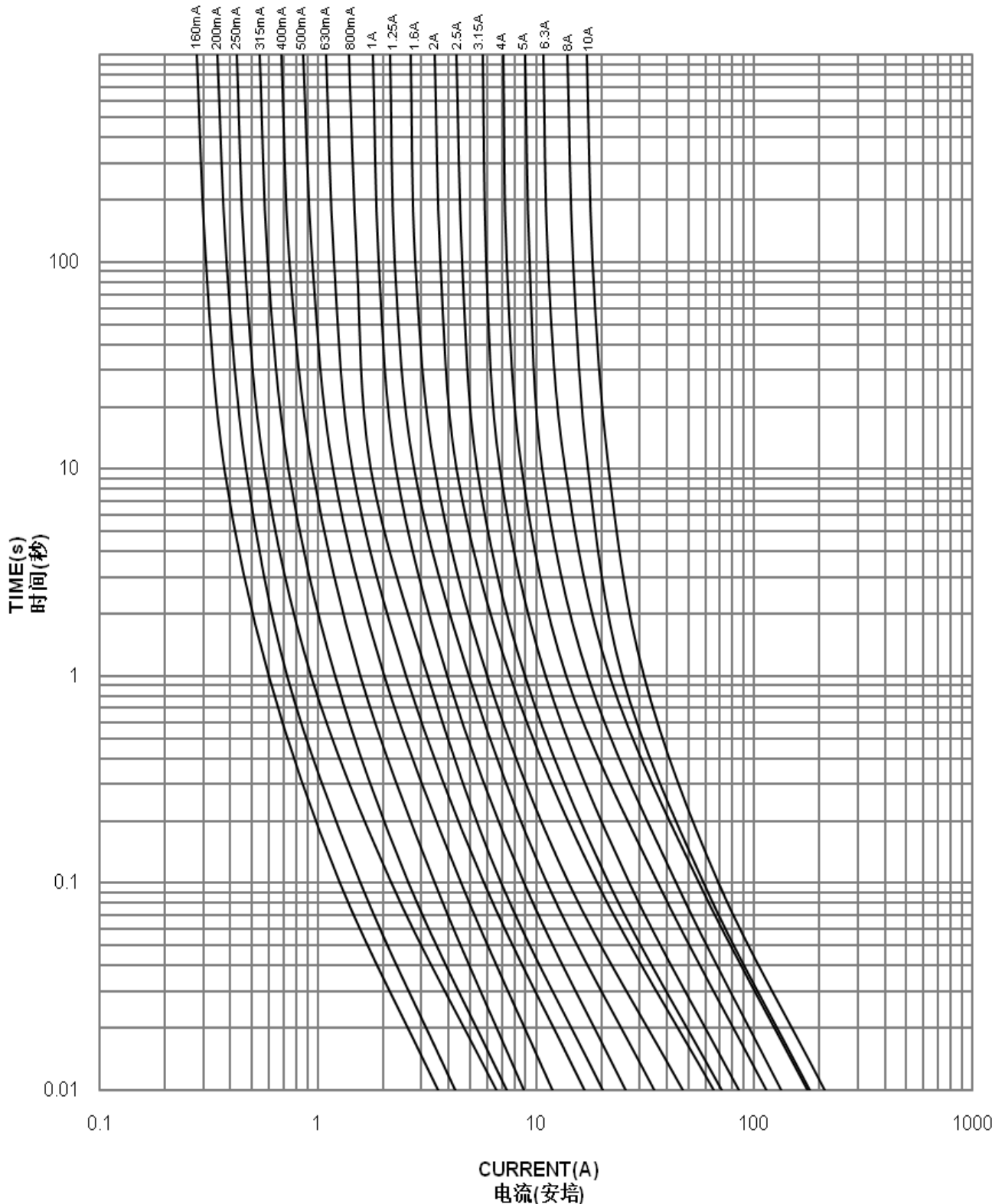

 XIAMEN DEXIAN ELECTRONICS TECHNOLOGY CO., LTD	PRODUCT SPECIFICATION	ISSUED DATE:	2023/02/27
		REV. NO.:	A05
	SERIES: DET	DOC. NO.:	DX-PSI-001
		PAGE	PAGE 5 OF 9

6.7 平均 I²T-T 特性曲线图(仅供参考) / THE AVERAGE I²T-T CHARACTERISTICS CURVE(FOR REFERENCE ONLY)

DET Average I²T-T Characteristics Curve(For Reference Only)

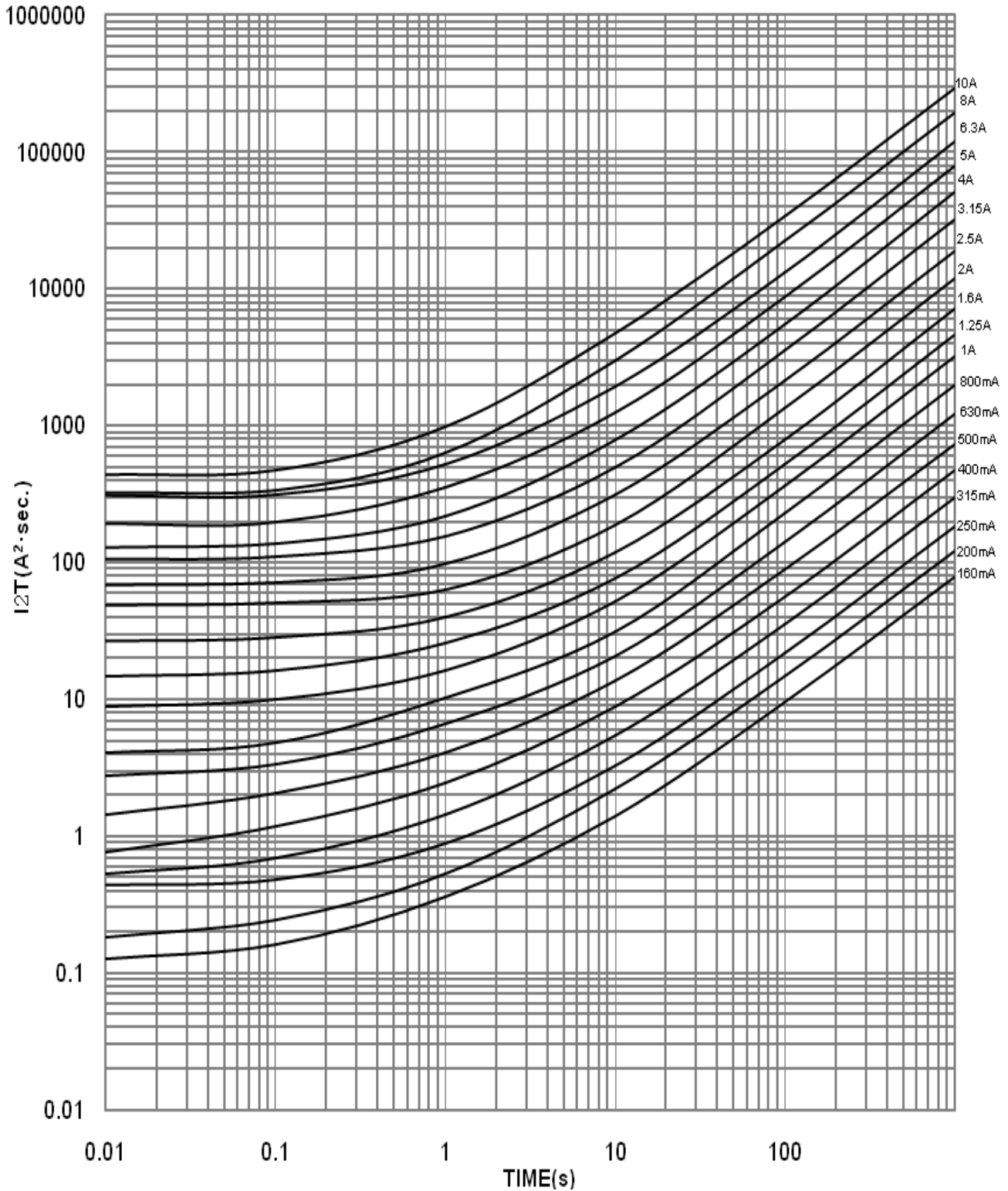

 XIAMEN DEXIAN ELECTRONICS TECHNOLOGY CO., LTD	PRODUCT SPECIFICATION	ISSUED DATE:	2023/02/27
		REV. NO.:	A05
	SERIES: DET	DOC. NO.:	DX-PSI-001
		PAGE	PAGE 6 OF 9

6.8 焊接参数/ SOLDERING PARAMETERS

1) 波峰焊接/ Wave soldering: 260°C, 10sec. Max..

建议波峰焊接图形/ Suggest wave soldering graphics

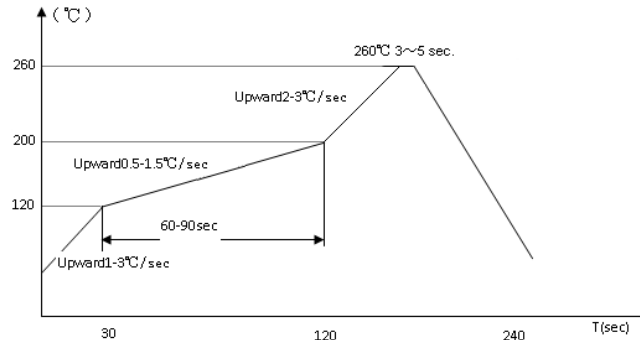

2) 手工焊接/ Manual soldering: 300°C, 3sec. Max..

3) 耐热焊接/ Resistance to soldering heat: 260°C, 10sec. Max..

6.9 工作温度/ OPERATING TEMPERATURE: -55°C ~ +125°C.

6.10 储存温度/ STORAGE TEMPERATURE: -55°C ~ +85°C.

6.11 保存条件 Storage Conditions

相对湿度 ≤ 75%，可存放 1 年。

Relative humidity ≤ 75%, store 1 years .

6.12 电阻测试/ COLD RESISTANCE TEST

环境温度为 25±2°C，测试电流不大于保险丝额定电流的 10%。

Input less than or equal to 10% of fuse rated current to fuse for cold resistance test at surrounding temperature of 25±2°C.

6.13 相比漏电起痕指数(CTI)/ Comparative Tracking Index(CTI)

CTI 475 V，根据 IEC 60112 《固体绝缘材料耐电痕化指数和相比电痕化指数的测定方法》。

CTI 475V, according IEC 60112 "Method for the determination of the proof and the comparative tracking indices of solid insulating materials".



7. 产品标志/ MARKING

7.1 保险丝上的标志应易于看清。

The relevant markings shall be marked on round thermoplastic cap and shall be easily visible.

7.2 每个保险丝应标有下列标记

The markings for every fuse shall be prescribed as below according to the types:

- 1) 安全认证标志/ Safety Approval Logo: 
- 2) 商标/ Trademark: 
- 3) 特性符号/ Characteristics Symbol: T
- 4) 额定电流/ Rated Current
- 5) 额定电压/ Rated Voltage

7.3 标签应包括：型号、额定电流、额定电压、安全标志、批量号码、绿色的“QA”和“G”签章。

The label shall contain the Type, Rated current, Rated voltage, Safety approval logo, Lot. No., "QA" & "G" seals in green.

8. 包装要求/ PACKING DETAILS

8.1 包装方式 A/ PACKING MODE A

8.1.1 编带式包装：按编号 DXBZ-001 图纸要求包装。

AMMO-PACK: according to the drawing (No.: DXBZ-001) (Please see the attachment).

8.2 包装方式 B/ PACKING MODE B

散装包装/ BULK PACKING:

8.2.1 短引线/ Short Lead(L≤5mm)(按编号 DXBZ-002 图纸要求包装)

8.2.1.1 塑料袋参考尺寸 Plastic Bag Size: 长×宽×厚 length × width × thickness = 140×100×0.07mm.

8.2.1.2 内盒参考尺寸 Inner Box Size: 长×宽×高 length × width × height = 140×100×60mm.

8.2.1.3 外箱参考尺寸 External Carton Size: 长×宽×高 length × width × height = 320×240×165mm.

 XIAMEN DEXIAN ELECTRONICS TECHNOLOGY CO., LTD	PRODUCT SPECIFICATION	ISSUED DATE:	2023/02/27
		REV. NO.:	A05
	SERIES: DET	DOC. NO.:	DX-PSI-001
		PAGE	PAGE 7 OF 9

8.2.1.4 包装要求 Packing Details: 250 个/袋; 4 袋/盒; 10 盒/箱。250EA/ Bag; 4 Bags / Box; 10 Boxes / Exported Carton.

8.2.2 长引线/ Long lead(18.9mm)

8.2.2.1 内盒参考尺寸 Inner Box Size:长×宽×高 length × width × height=65×65×230mm

8.2.2.2 外箱参考尺寸 External Carton Size: 长×宽×高 length × width × height= 335×295×260mm

8.2.2.3 包装要求: 500 个/内盒 (内垫一层气泡布); 20 内盒/外箱。

Packing Details: 500EA/ Inner Box (put one layer bubble film in each inner box); 20 Inner Boxes/ External Carton.

8.3 所有产品的包装应能达到防潮、抗振的作用, 以防在运输或贮存过程中产品受潮或损坏/ Packing should meet the requirements of anti-moisture and anti-shaking so that the products will not absorb moisture or be damaged during transportation or storage.

9 信赖性试验/ RELIABILITY TEST

Test Description	Testing condition	Acceptance Criteria
Temperature rise test	100% testing current, 1h	≤75℃
Resistance to soldering heat test	Use 1.5±0.5mm PCB, dip solder bath 260±5℃, 10±3sec.	<10% variation on DCR & V-drop
Endurance test	100% testing current, 100 cycles, 1h on /15 min. off	<10% variation on DCR &V-drop
Maximum sustained dissipation	After the endurance test, measure at 150% testing current, 1h	≤specified value
Test at elevated temperature	70±2℃, 100% testing current, 1h	<10% variation on DCR &V-drop
Solderability test, no aging	Immerse to flux 5±1sec. then dip in solder bath 245±5℃, 10±0.5sec.	Solder coverage>95% of the termination surface
Solderability test, dry aging, 155±5℃, 16hrs	Immerse to flux 5±1sec. then dip in solder bath 245±5℃, 10±0.5sec.	Solder coverage>95% of the termination surface
Solderability test, steam aging, 8hrs	Immerse to flux 5±1sec. then dip in solder bath 245±5℃, 10±0.5sec.	Solder coverage>95% of the termination surface
Temperature cycle test	10 cycles, -40℃/ 30 min. to 85℃/ 30 min.	<10% variation on DCR &V-drop
Steady life test	100% testing current, 100hrs, 25±5℃	<10% variation on DCR &V-drop
Humidity test	40±2℃, 90~95%RH, 96hrs	<10% variation on DCR &V-drop
High Temperature Test	105±2℃, 1000hrs	<10% variation on DCR &V-drop
Low Temperature Test	-20±2℃, 1000hrs	<10% variation on DCR &V-drop
Vibration Test	10-55-10HZ, 1.25mm, 8hrs of each axis in XYZ direction	<10% variation on DCR &V-drop
Salt Spray Test	35±2℃, 5% Salt Water Spray, 48hrs	<10% variation on DCR &V-drop



**XIAMEN DEXIAN ELECTRONICS
TECHNOLOGY CO., LTD**

PRODUCT SPECIFICATION

SERIES: DET

ISSUED DATE: 2023/02/27

REV. NO.: A05

DOC. NO.: DX-PSI-001

PAGE PAGE 8 OF 9

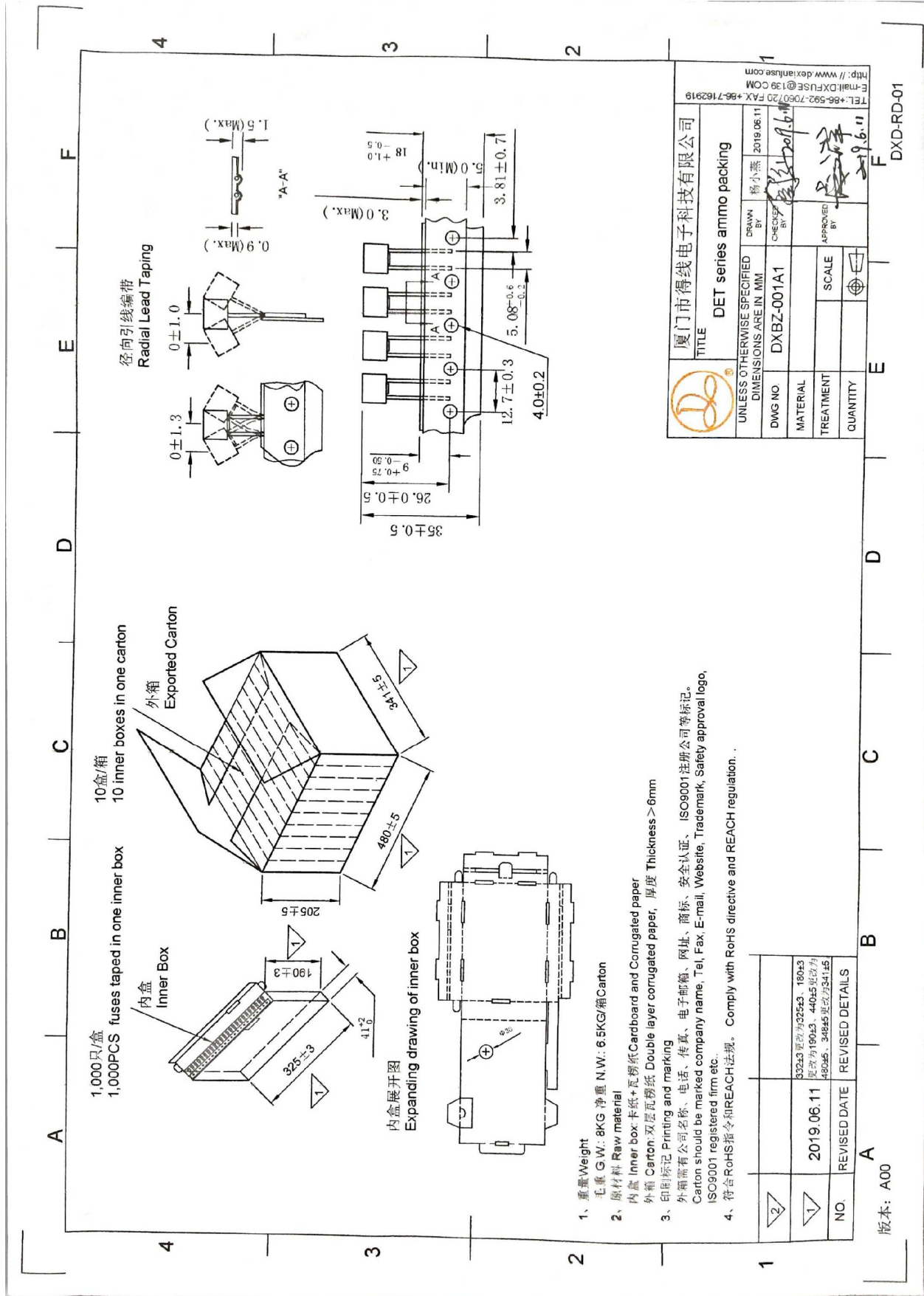

1,000只/盒
1,000PCS fuses taped in one inner box

10盒/箱
10 inner boxes in one carton

内盒
Inner Box

外箱
Exported Carton

内盒展开图
Expanding drawing of inner box

- 重量Weight
毛重 G.W.: 8KG 净重 N.W.: 6.5KG/箱Carton
- 原材料 Raw material
内盒 Inner box: 卡纸+瓦楞纸Cardboard and Corrugated paper
外箱 Carton: 双层瓦楞纸 Double layer corrugated paper, 厚度 Thickness > 6mm
- 印刷标记 Printing and marking
外箱需有公司名称、电话、传真、电子邮箱、网址、商标、安全认证、ISO9001注册公司等标记。
Carton should be marked company name, Tel, Fax, E-mail, Website, Trademark, Safety approval logo, ISO9001 registered firm etc.
- 符合RoHS指令和REACH法规。 Comply with RoHS directive and REACH regulation.

		厦门市得线电子科技有限公司 TITLE DET series ammo packing	
UNLESS OTHERWISE SPECIFIED DIMENSIONS ARE IN MM		DRAWN BY: 杨小燕 2019.06.11	CHECKED BY: [Signature] 2019.06.11
DWG NO:	DXBZ-001A1	MATERIAL:	
TREATMENT:		SCALE:	
QUANTITY:		APPROVED BY:	[Signature]

NO.	REVISED DATE	REVISED DETAILS
1	2019.06.11	33243 更改为 32543、180*43 更改为 190*43、440*45 更改为 480*45、348*45 更改为 341*45

版本: A00

DXD-RD-01



**XIAMEN DEXIAN ELECTRONICS
TECHNOLOGY CO., LTD**

PRODUCT SPECIFICATION

SERIES: DET

ISSUED DATE: 2023/02/27

REV. NO.: A05

DOC. NO.: DX-PSI-001

PAGE PAGE 9 OF 9

A B C D E F

内盒展开图
Expanding drawing of inner box

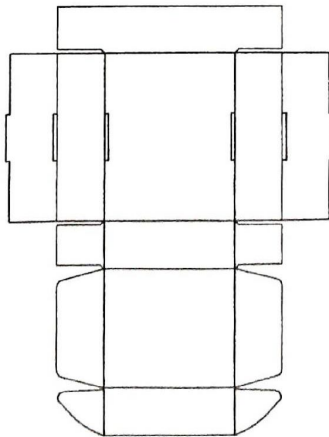

内盒
Inner box

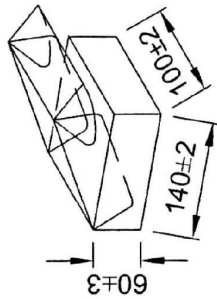

250pcs/塑料袋, 4 塑料袋/内盒;
250pcs/ Plastic bag, 4 Plastic bags/ Inner box
塑料袋规格 Plastic bag size:
140mm X 100mm X 0.07 mm;

外箱
Carton

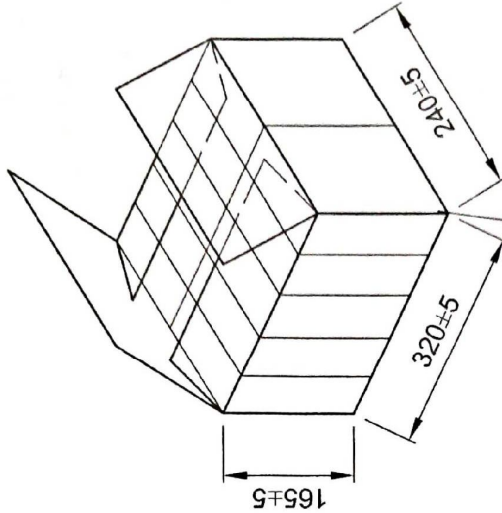

10内盒 Inner boxes/箱 Carton

The inside of the carton is two layers of bubble cloth
外箱内部上下两层各放一片气泡垫

- 1、原材料 Raw material
内盒 Inner box: 半纸+瓦楞纸 Corrugated board and Corrugated paper
外箱 Carton: 双层瓦楞纸 Double layer corrugated paper, 厚度 Thickness >6mm
- 2、印刷标记 Printing and marking
外箱需有公司名称、电话、传真、电子邮箱、网址、商标、安全认证、CICC ISO9001 2015注册公司等标记。
Carton should be marked company name, Tel, Fax, E-mail, Website, Trademark, Safety approval logo, CICC ISO9001:2015 registered firm etc marked
- 3、符合RoHS指令和REACH法规。 Comply with RoHS directive and REACH regulation.

		Xiamen Dexian Electronics Technology Co., Ltd.	
TITLE		DET series bulk packing (引线长度 ≤ 5mm)	
UNLESS OTHERWISE SPECIFIED DIMENSIONS ARE IN MM		DATE	2019.06.05
DWG NO	DXBZ-002A0	CHECKED BY	蔡小燕
MATERIAL		APPROVED BY	蔡小燕
TREATMENT		SCALE	
QUANTITY			

TEL: +86-592-7163111 FAX: +86-592-7163112
E-mail: dxrse@dexianfuso.com
http://www.dexianfuso.com

DX-RD-01

NO.	REVISED DATE	REVISED DETAILS
2		
1		

版本: A00

单击下面可查看定价，库存，交付和生命周期等信息

[>>DXFUSE\(厦门得线\)](#)