

## Switching Regulator Series

# Synchronous Buck-Boost DC/DC Converter BD83070GWL Evaluation Board

BD83070GWL-EVK-001

## Introduction

This application note will provide the steps necessary to operate and evaluate ROHM's synchronous buck-boost DC/DC converter using BD83070GWL evaluation board. Component selection and operating procedures are included.

## Description

The BD83070GWL converter is a power supply solution designed for battery powered devices. It can operate at pulse frequency modulation (PFM) to suppress loss and current consumption during light load which has 2.8 $\mu$ A quiescent current at no load. Capable to support up to 1A output on pulse width modulation (PWM) and provides high efficiency for heavy load. It is possible to disable auto-PFM/PWM mode by via MODE pin. User can select from 2 preset output voltage via VSEL pin and it changes between buck and boost operations depending on the relation between input voltage and output voltage.

## Application

Single Cell Li-ion or 3 Cell NiMH Battery-Powered Portable  
Products  
Tablet Terminal Device  
Smartphone

## Features

Automation PFM/PWM Mode and Fixed PWM Mode  
Input Voltage Range: 2.0 V to 5.5 V  
Output Current: Up To 1 A ( $V_{IN} > 2.7$  V,  $V_{OUT} = 3.3$  V)  
Selectable Output Voltage: 2.5 V or 3.3 V  
Efficiency: Up To 95 %  
UVLO Detection: 1.61 V(Max)  
Built-in Thermal, Over Voltage, And Over Current Protection

## Key Specifications

Input Voltage Range: 2.0 V to 5.5 V  
Output Voltage: 3.3 V or 2.5V  
Output Current: 1 A  
Switching Frequency: 1.5 MHz(Typ)  
Quiescent  $V_{IN}$  Current: 2.8  $\mu$ A(Typ)  
UCSP50L1C package (1.20 mm  $\times$  1.60 mm  $\times$  0.57 mm)

## Evaluation Board Operating Limits

Parameter	Symbol	Limit			Unit	Conditions
		MIN	TYP	MAX		
Supply Voltage	$V_{IN}$	2.0	-	5.5	V	
Output Current	$I_{OUT}$	1	-	-	A	$V_{IN} > 2.7V$ , $V_{OUT} = 3.3V$

**Evaluation Board**

Material of PCB: FR-4  
 Number of Layer: 4  
 PCB thickness: 1.4mm

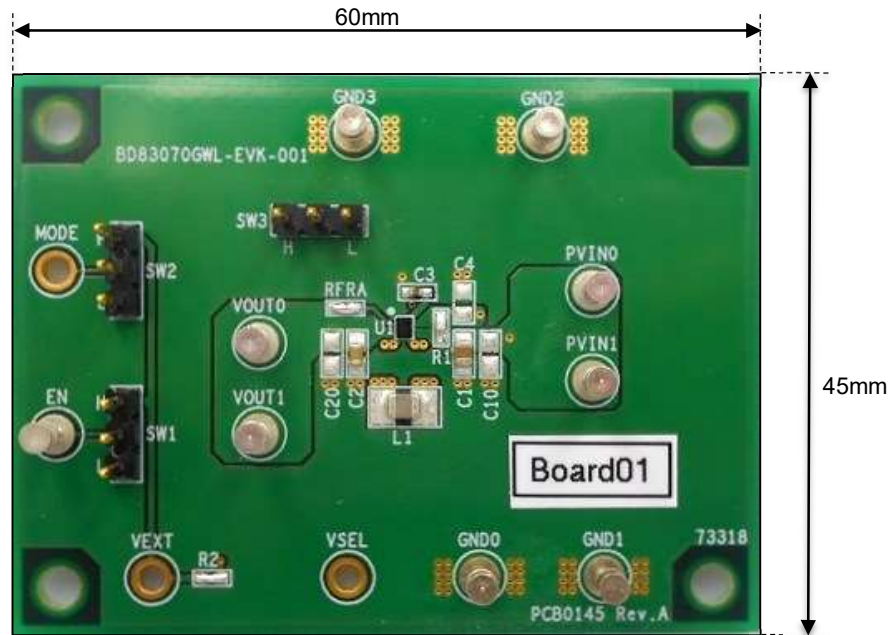

Figure 1. BD83070GWL Evaluation Board

**Board Schematic**

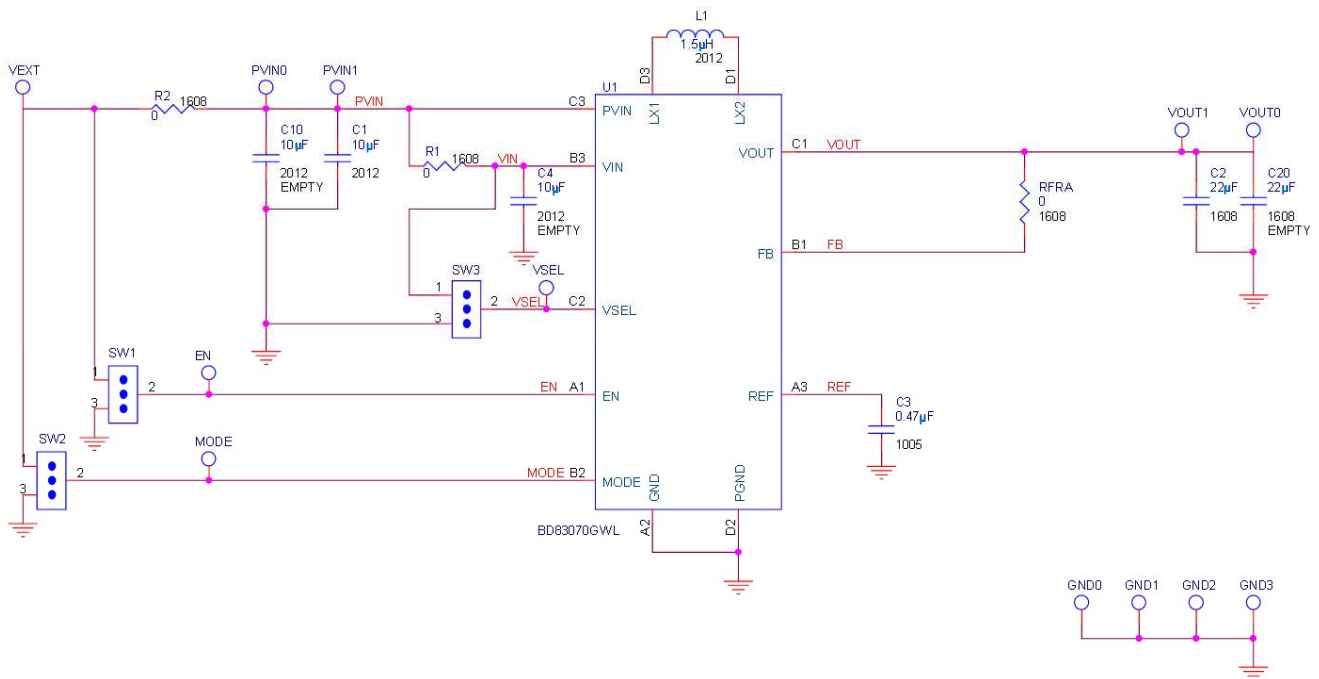

Figure 2. BD83070GWL Evaluation Board Schematic

## Output Voltage Settings

Below is a table of output voltages selectable using VSEL pin.

VSEL Pin	VOUT
HIGH ( $\geq V_{IN}-0.3\text{ V}$ )	3.3V
LOW ( $\leq 0.3\text{ V}$ )	2.5V

Table 1. Output Voltage Settings

## Operation State Settings

Below is a table of BD83070GWL Condition selectable using EN pin.

EN Pin	BD83070GWL Condition
HIGH ( $\geq 1.2\text{ V}$ )	Enable
LOW ( $\leq 0.4\text{ V}$ )	Shutdown

Table 2. EN Pin Settings

## Operation Mode Settings

Below is a table of operation modes selectable using MODE pin.

MODE Pin	MODE
HIGH ( $\geq 1.2\text{ V}$ )	Forced PWM
LOW ( $\leq 0.4\text{ V}$ )	Automatic PFM-PWM

Table 3. MODE Pin Settings

## Evaluation Board BOM

Below is a table showing the Bill of Materials. Part numbers and suppliers are included.

Reference	Part Number	Manufacturer	Description [Unit: inch (mm)]	Qty.
C1	GRM21BR61C106ME15	Murata	10 $\mu$ F, 16V, X5R, 0805 (2012)	1
C2	GRM188R60J226MEA0D	Murata	22 $\mu$ F, 6.3V, X5R, 0603 (1608)	1
C3	CGB2A1X5R1C474M033BC	TDK	0.47 $\mu$ F, 16V, X5R, 0402 (1005)	1
C10, C20, C4			Open	3
L1	1239AS-H-1R5M	Murata	1.5 $\mu$ H, 1A, 1008 (2520)	1
RFRA, R1, R2			Short	3
SW1, SW2, SW3	68000-103HLF	FCI	CONN HEADER VERT, .100, 3POS, 15AU	3
EN	1502-2	Keystone Electronics	TEST POINT PC MULTI PURPOSE	1
GND0, GND1, GND2, GND3	1502-2	Keystone Electronics	TEST POINT PC MULTI PURPOSE	4
PVIN0, PVIN1	1502-2	Keystone Electronics	TEST POINT PC MULTI PURPOSE	2
VOUT0, VOUT1	1502-2	Keystone Electronics	TEST POINT PC MULTI PURPOSE	2
U1	BD83070GWL	ROHM	3.3V 2A Buck-Boost DC/DC	1

Table 4: Bill of Materials

## Board Operating Procedure

1. Set the output voltage using the switch settings at SW3. (refer to Table 1)
2. Set the operation mode using the switch settings at SW2. (refer to Table 3)
3. Disable the IC by setting the SW1 jumper to the upper position (EN  $\rightarrow$  GND).
4. Connect the power supply's GND terminal to one of each of the GND0, GND1, GND2, GND3 test point on the evaluation board.
5. Connect the power supply's VCC terminal to the PVIN0 test point on the evaluation board. This will provide VIN to the IC. Please note that VIN should be in the range of 2.0V to 5.5V.
6. Connect the electronic load to one of each of GND0-3 and VOUT0. Connect the voltmeter to one of each of GND0-3 and VOUT1.
7. Turn on the power supply and enable the IC by setting the jumper at SW1 to the lower position (EN  $\rightarrow$  VSYS). The output voltage can be measured at test point VOUT. Now turn on the load. The load can be increased up to 1.0A.

### Board Layout

The following are layers of the Evaluation Board of BD83070GWL

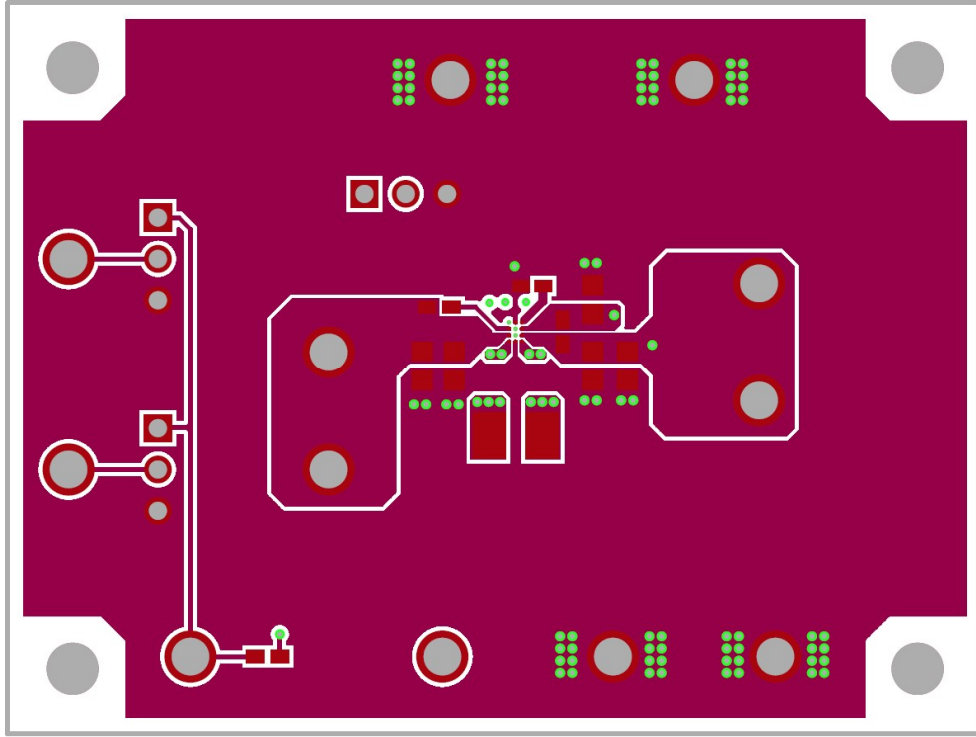

Figure 3. Top Layer

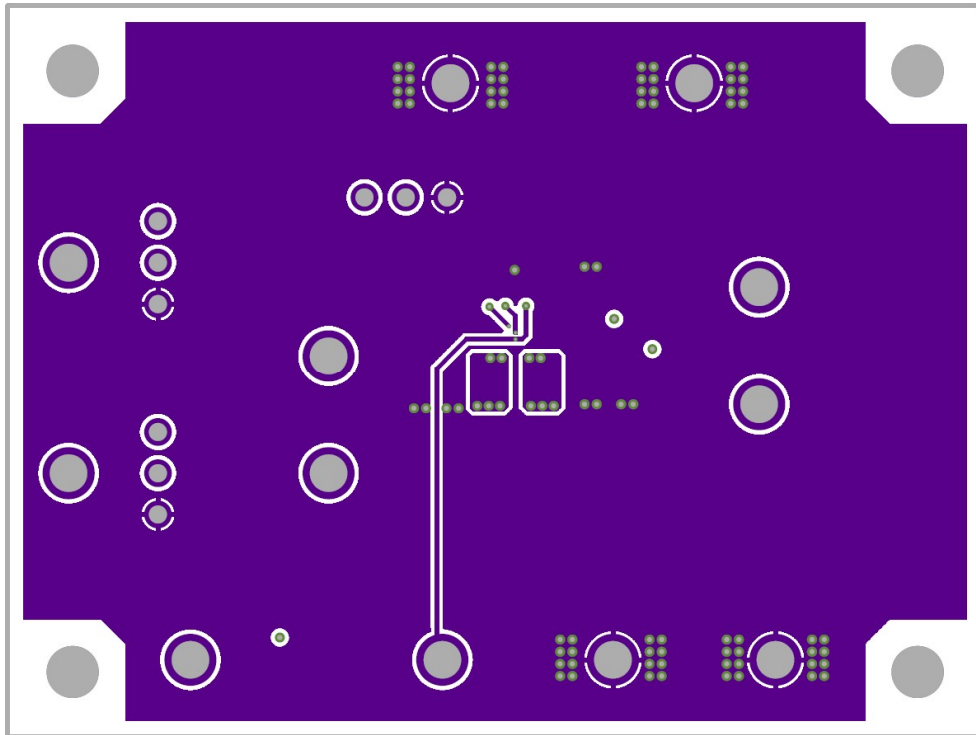

Figure 4. Middle 1 Layer

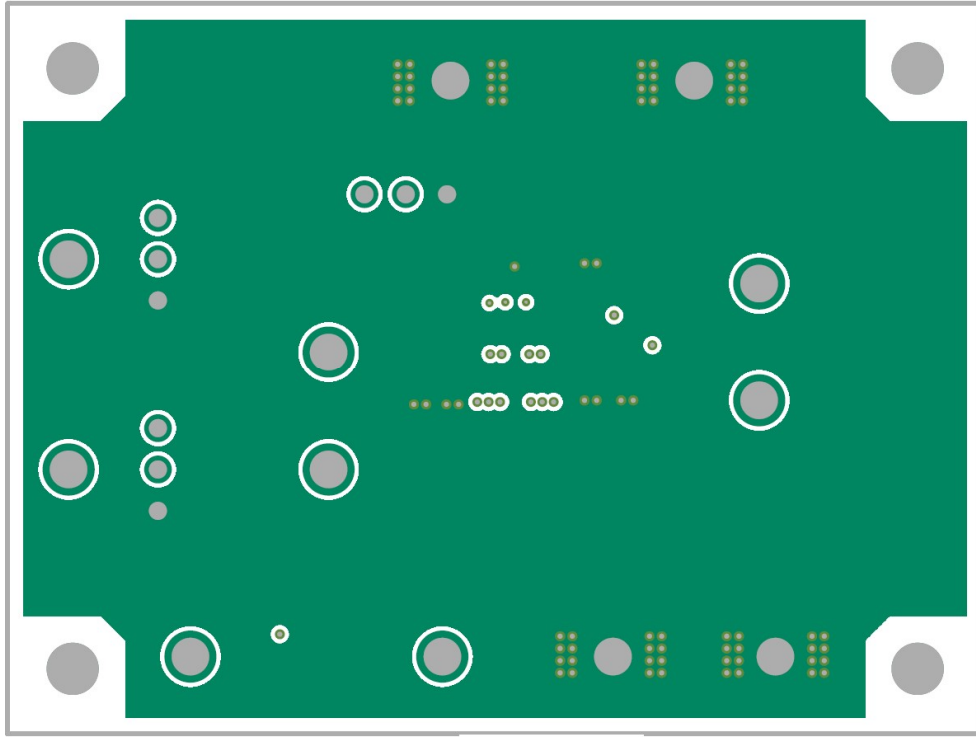

Figure 5. Middle 2 Layer

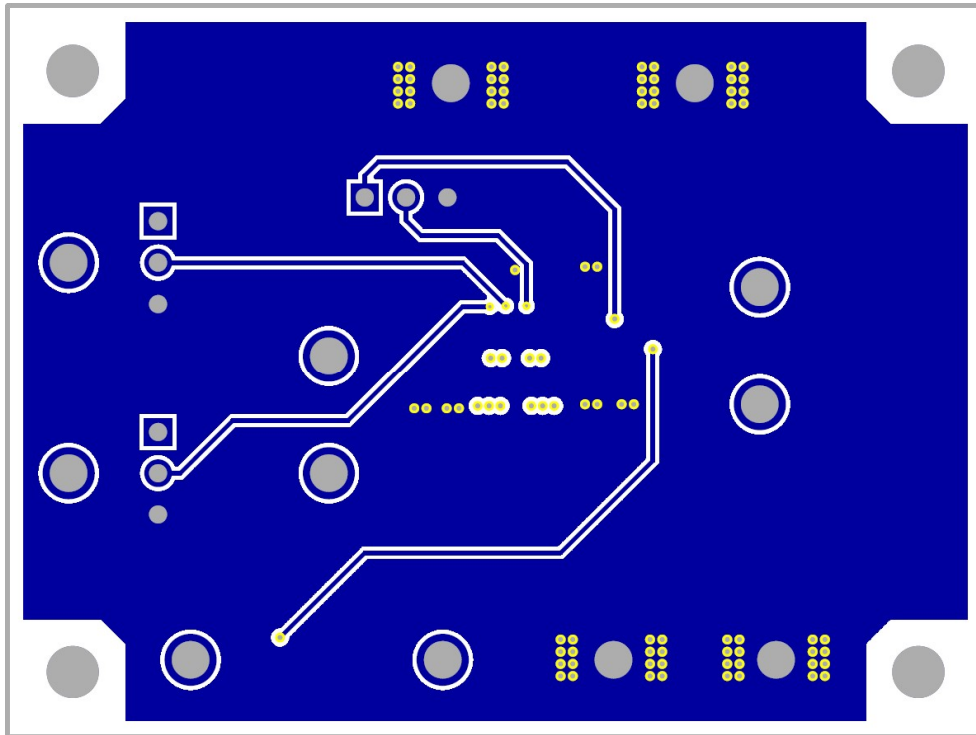

Figure 6. Bottom Layer

Reference Application Data

The following are graphs of efficiency, switching frequency, load response, output voltage, ripple, startup and shutdown.

Typical Performance Curves

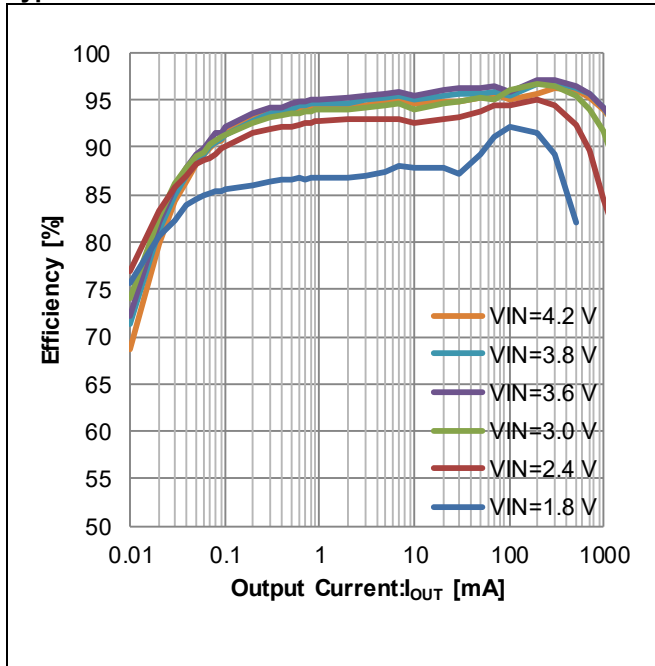

Figure 7. Efficiency vs Output Current (VSEL=High, MODE=Low: Auto-PFM/PWM)

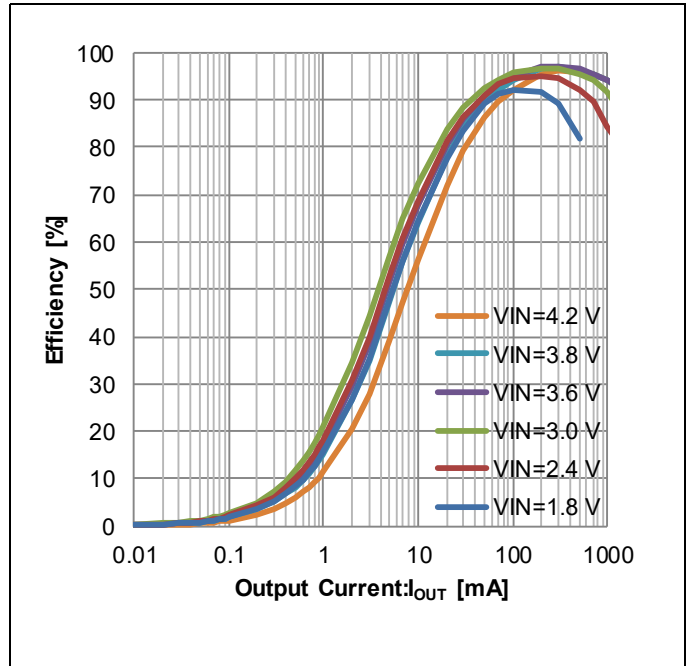

Figure 8. Efficiency vs Output Current (VSEL=High, MODE=High: Forced-PWM)

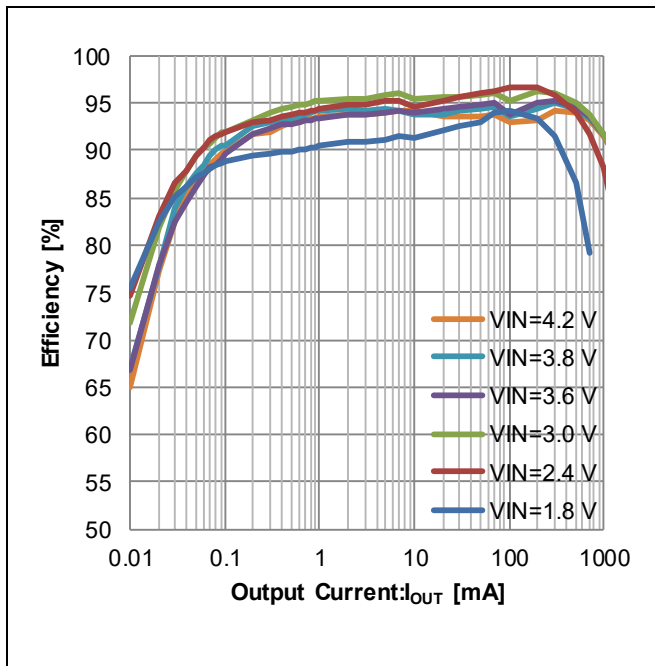

Figure 9. Efficiency vs Output Current (VSEL=Low, MODE=Low: Auto-PFM/PWM)

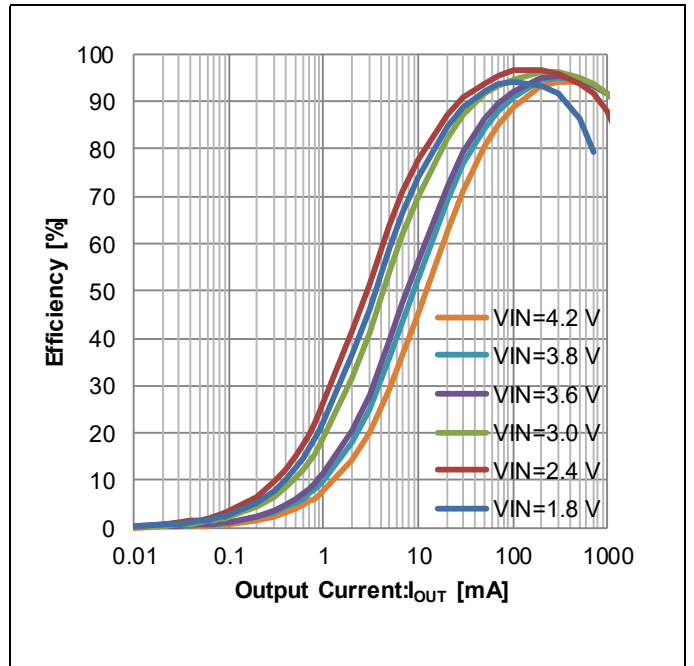

Figure 10. Efficiency vs Output Current (VSEL=Low, MODE=High: Forced-PWM)

Typical Performance Curves - continued

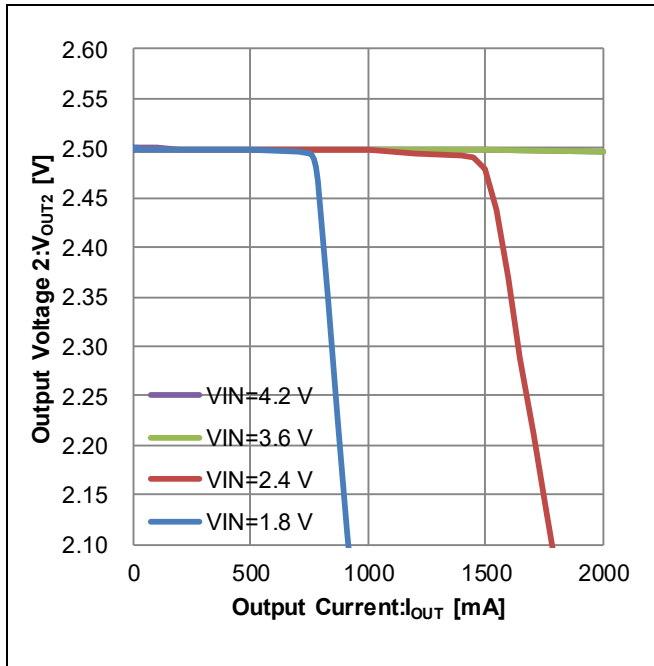

Figure 11. Output Voltage 2 vs Output Current (“Load Regulation”, VSEL=Low, MODE=High: Forced-PWM)

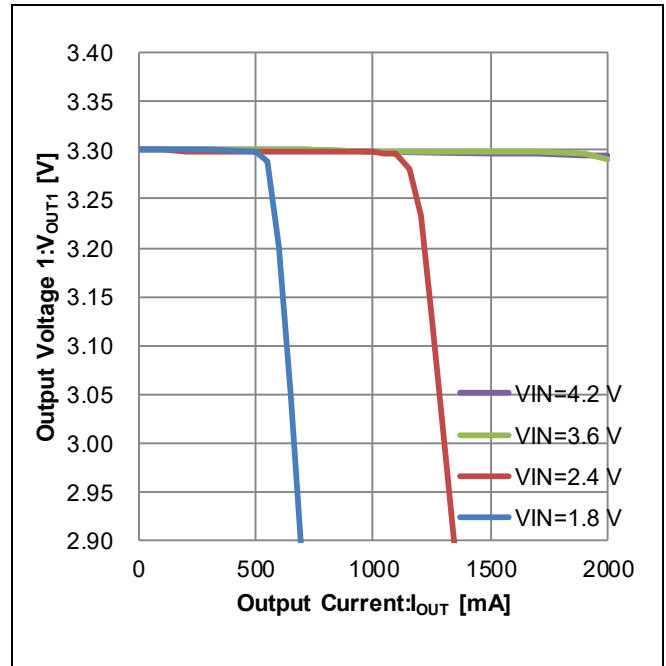

Figure 12. Output Voltage 1 vs Output Current (“Load Regulation”, VSEL=High, MODE=High: Forced-PWM)

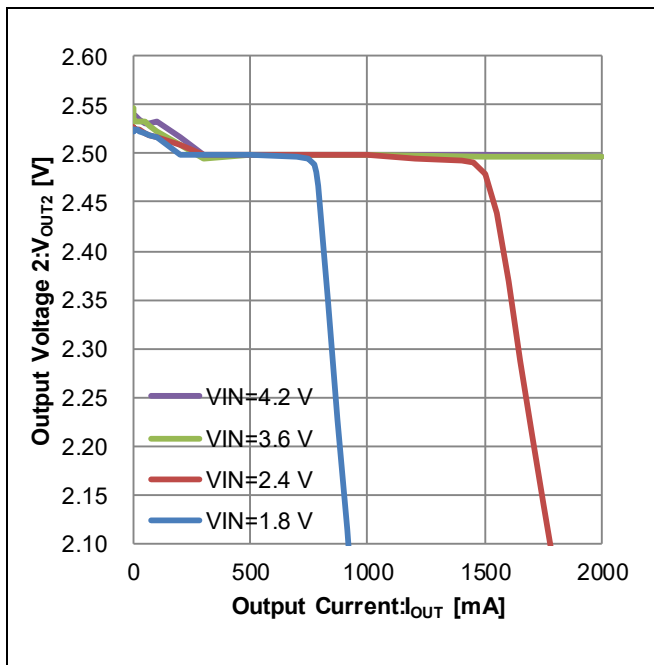

Figure 13. Output Voltage 2 vs Output Current (“Load Regulation”, VSEL=Low, MODE=Low: Auto-PFM/PWM)

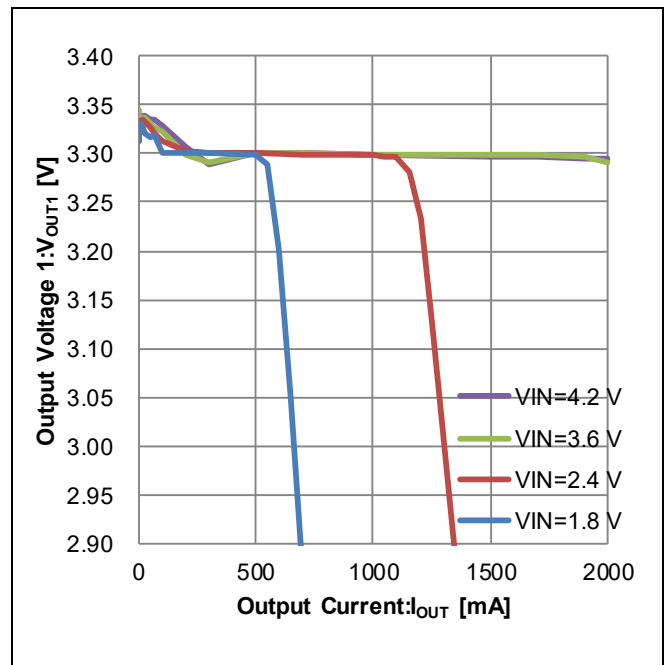

Figure 14. Output Voltage 1 vs Output Current (“Load Regulation”, VSEL=High, MODE=Low: Auto-PFM/PWM)



Typical Performance Curves - continued

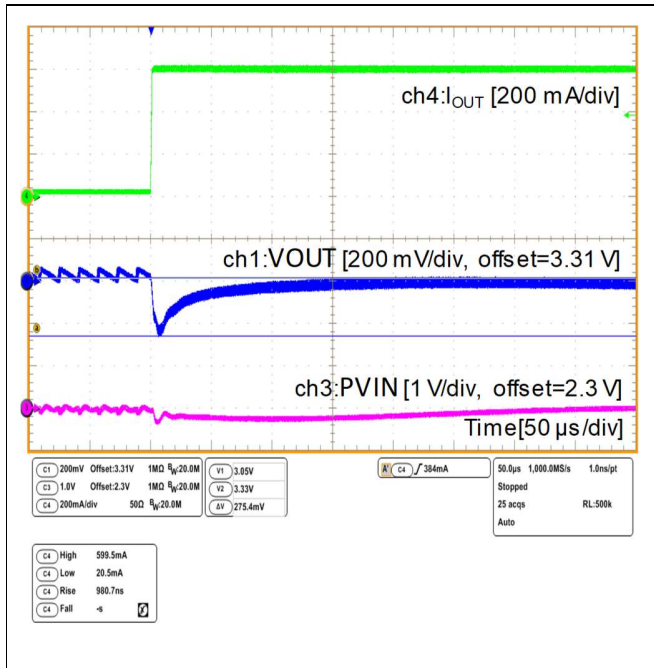

Figure 15. Transient Response  
(VIN=2.3 V, VSEL=High, MODE=Low: Auto-PFM/PWM,  
Output current 20 mA->600 mA)

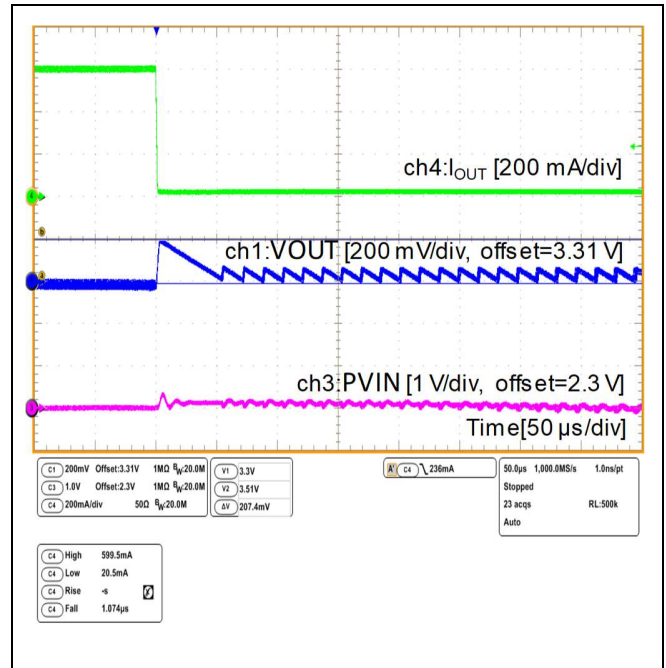

Figure 16. Transient Response  
(VIN=2.3 V, VSEL=High, MODE=Low: Auto-PFM/PWM,  
Output current 600 mA->20 mA)

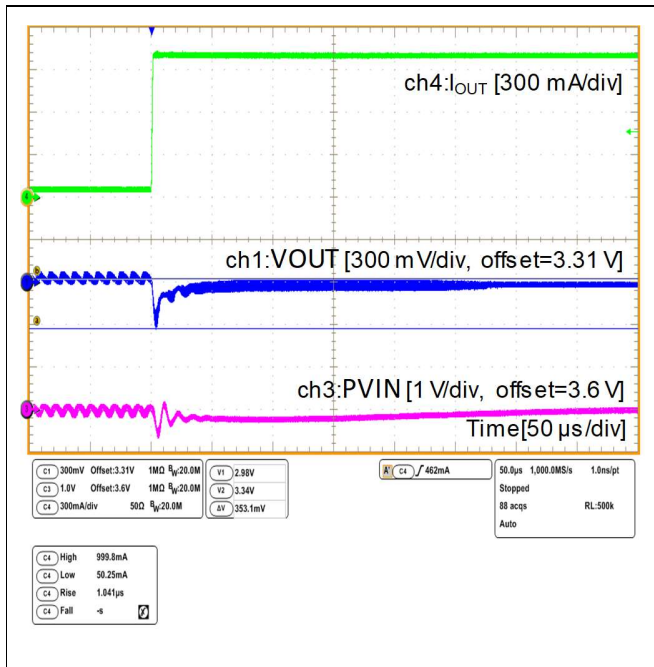

Figure 17. Transient Response  
(VIN=3.6 V, VSEL=High, MODE=Low: Auto-PFM/PWM,  
Output current 50 mA->1000 mA)

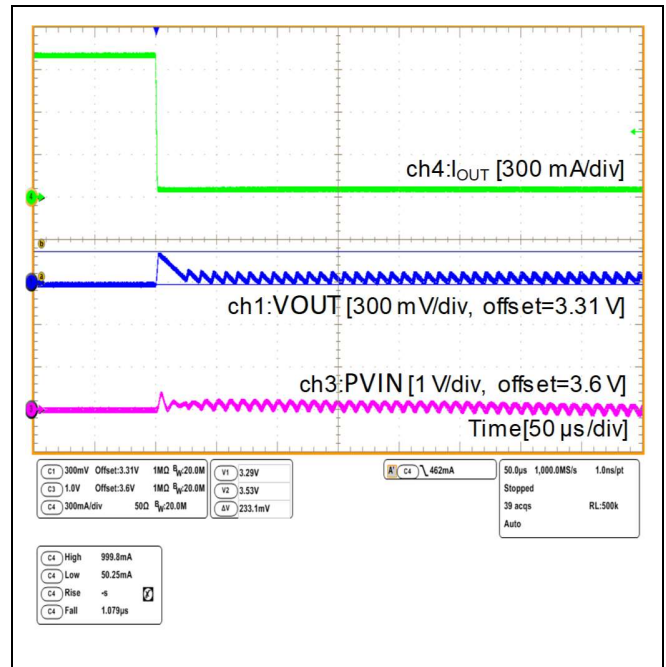

Figure 18. Transient Response  
(VIN=3.6 V, VSEL=High, MODE=Low: Auto-PFM/PWM,  
Output current 1000 mA->50 mA)

Typical Performance Curves - continued

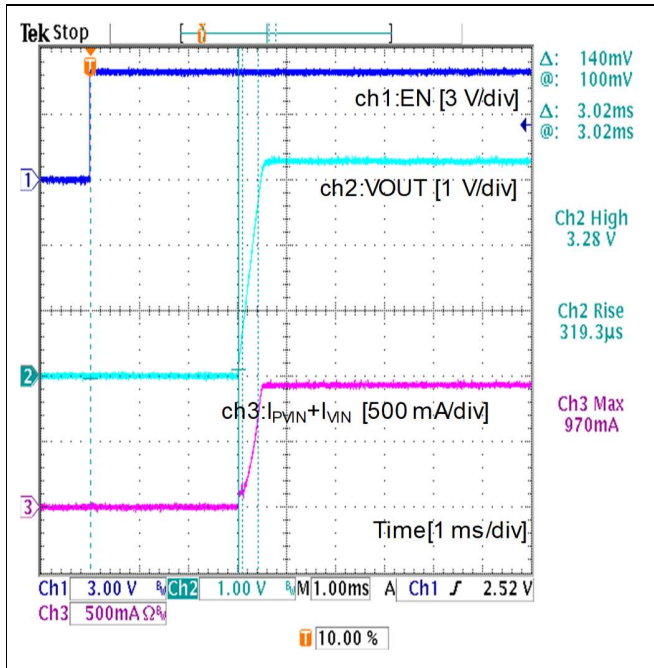

Figure 19. Startup Waveform  
(VIN=2.4 V, VSEL=High, MODE=High: Forced-PWM, 5.5 Ω resistive load)

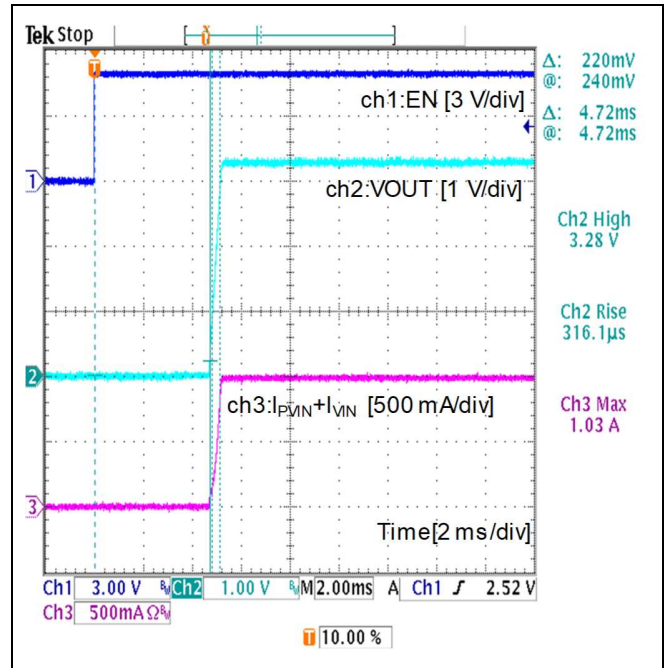

Figure 20. Startup Waveform  
(VIN=3.6 V, VSEL=High, MODE=High: Forced-PWM, 3.3 Ω resistive load)

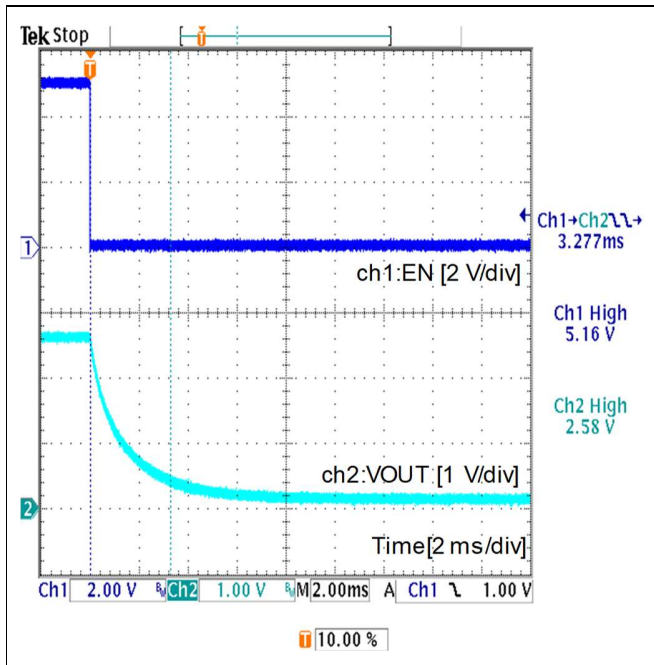

Figure 21. Shutdown Waveform  
(VIN=3.6 V, VSEL=Low, MODE=Low: Auto-PFM/PWM, No load)

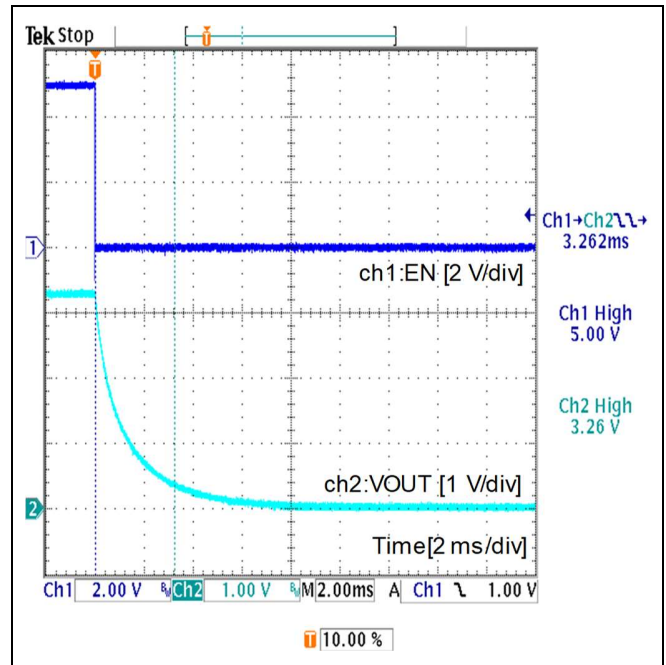

Figure 22. Shutdown Waveform  
(VIN=3.6 V, VSEL=High, MODE=Low: Auto-PFM/PWM, No load)

Typical Performance Curves - continued

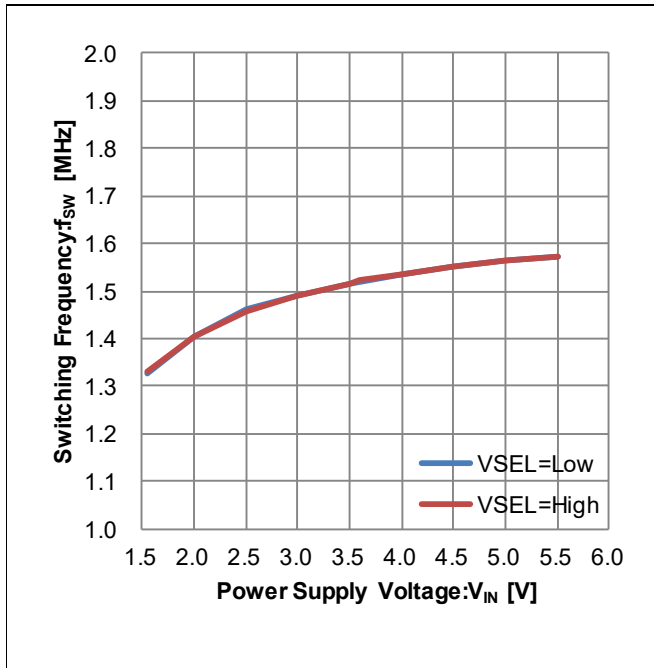

Figure 23. Switching Frequency vs Power Supply Voltage (MODE=High: Forced-PWM, No load)

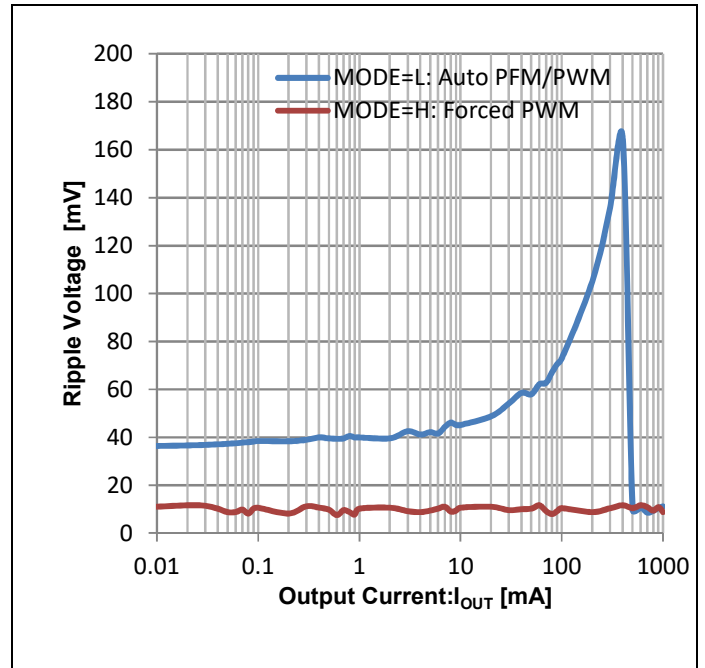

Figure 24. Ripple Voltage vs Output Current (VIN=3.6 V, VSEL=High)

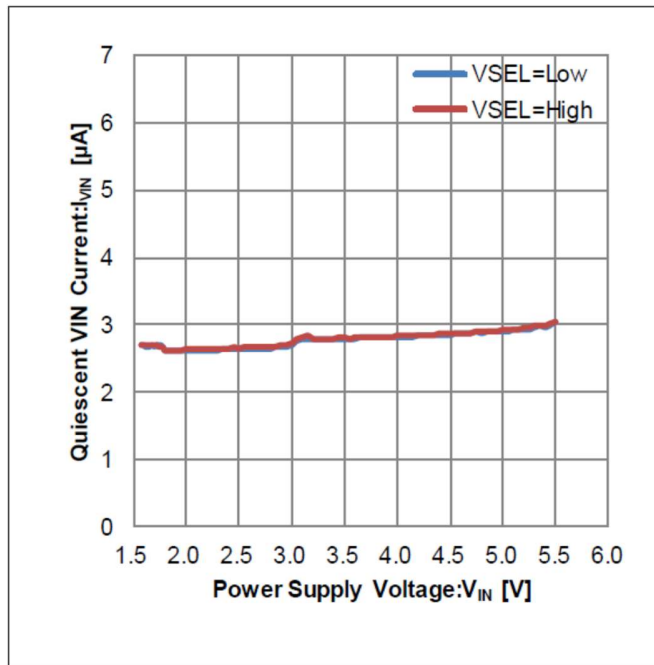

Figure 25. Quiescent VIN Current vs Power Supply Voltage (MODE=Low: Auto-PFM/PWM, FB=3.5V, No load)

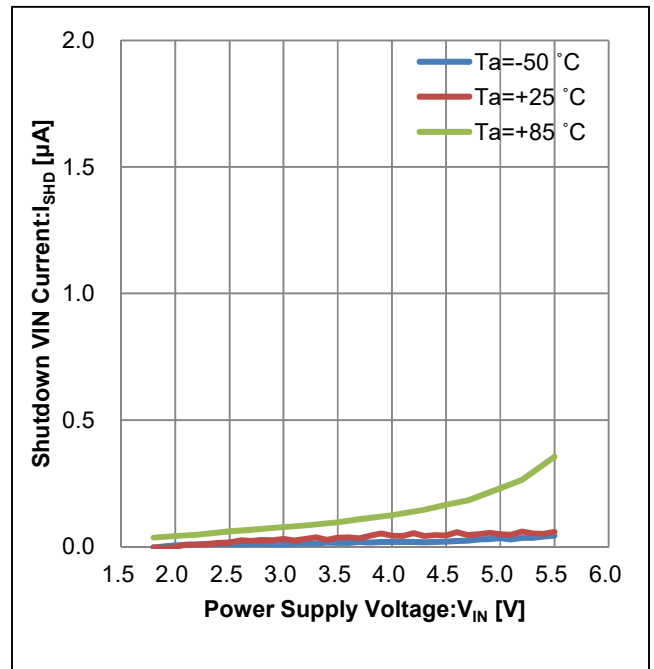

Figure 26. Shutdown VIN current vs Power Supply Voltage (EN=MODE=Low, No load)

**Revision History**

Date	Revision	Changes
10.Jun.2019	001	New Release

## Notes

- 1) The information contained herein is subject to change without notice.
- 2) Before you use our Products, please contact our sales representative and verify the latest specifications :
- 3) Although ROHM is continuously working to improve product reliability and quality, semiconductors can break down and malfunction due to various factors.  
Therefore, in order to prevent personal injury or fire arising from failure, please take safety measures such as complying with the derating characteristics, implementing redundant and fire prevention designs, and utilizing backups and fail-safe procedures. ROHM shall have no responsibility for any damages arising out of the use of our Products beyond the rating specified by ROHM.
- 4) Examples of application circuits, circuit constants and any other information contained herein are provided only to illustrate the standard usage and operations of the Products. The peripheral conditions must be taken into account when designing circuits for mass production.
- 5) The technical information specified herein is intended only to show the typical functions of and examples of application circuits for the Products. ROHM does not grant you, explicitly or implicitly, any license to use or exercise intellectual property or other rights held by ROHM or any other parties. ROHM shall have no responsibility whatsoever for any dispute arising out of the use of such technical information.
- 6) The Products specified in this document are not designed to be radiation tolerant.
- 7) For use of our Products in applications requiring a high degree of reliability (as exemplified below), please contact and consult with a ROHM representative : transportation equipment (i.e. cars, ships, trains), primary communication equipment, traffic lights, fire/crime prevention, safety equipment, medical systems, servers, solar cells, and power transmission systems.
- 8) Do not use our Products in applications requiring extremely high reliability, such as aerospace equipment, nuclear power control systems, and submarine repeaters.
- 9) ROHM shall have no responsibility for any damages or injury arising from non-compliance with the recommended usage conditions and specifications contained herein.
- 10) ROHM has used reasonable care to ensure the accuracy of the information contained in this document. However, ROHM does not warrants that such information is error-free, and ROHM shall have no responsibility for any damages arising from any inaccuracy or misprint of such information.
- 11) Please use the Products in accordance with any applicable environmental laws and regulations, such as the RoHS Directive. For more details, including RoHS compatibility, please contact a ROHM sales office. ROHM shall have no responsibility for any damages or losses resulting non-compliance with any applicable laws or regulations.
- 12) When providing our Products and technologies contained in this document to other countries, you must abide by the procedures and provisions stipulated in all applicable export laws and regulations, including without limitation the US Export Administration Regulations and the Foreign Exchange and Foreign Trade Act.
- 13) This document, in part or in whole, may not be reprinted or reproduced without prior consent of ROHM.



Thank you for your accessing to ROHM product informations.  
More detail product informations and catalogs are available, please contact us.

## ROHM Customer Support System

<http://www.rohm.com/contact/>

单击下面可查看定价，库存，交付和生命周期等信息

[>>ROHM Semiconductor\(罗姆\)](#)