

BCT8005

2.8W Mono Class D Audio Power Amplifier

GENERAL DESCRIPTION

The BCT8005 is a 2.8W mono filter-less Class-D amplifier with high PSRR and differential input that eliminate noise and RF rectification.

Features like greater than 90% efficiency and small PCB area make the BCT8005 Class-D amplifier ideal for portable applications. The output uses a filter-less architecture minimizing the number of external components and PCB area whilst providing a high performance, simple and lower cost system.

The BCT8005 features over current protection and thermal shutdown.

The BCT8005 is available in 8-pin package. This device operates over the -40°C to +85°C extended temperature range.



FEATURES

- 2.8V to 5.5V Single-Supply Operation
- POUT at 10% THD+N, f=1kHz, VCC=5V
RL=8 Ω 1.67W (Typ.)
RL=4 Ω 2.80W (Typ.)
- -80dB PSRR at 1kHz
- High Efficiency up to 90%
- Over current Protection
- Thermal Shutdown
- Available packages:
-SOP8
-MSOP8
-DFN2x2-8L
- Temperature Range: -40°C to 85°C

APPLICATIONS

- MP3/MP4
- Smart Speaker
- Portable Instrumentation

ORDERING INFORMATION

Order Number	Package Type	Temperature Range	Marking	QTY/Reel
BCT8005EOA-TR	SOP8	-40°C to +85°C	 8005 XXXXX	4000
BCT8005EMA-TR	MSOP8	-40°C to +85°C	 8005 XXXXX	4000
BCT8005ELA-TR	DFN2x2-8L	-40°C to +85°C	8005 XXXXX	3000

Note: "XXXXX" in Marking will be appeared as the batch code.

PIN CONFIGURATION

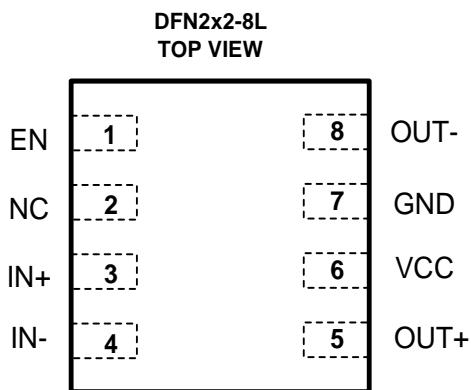
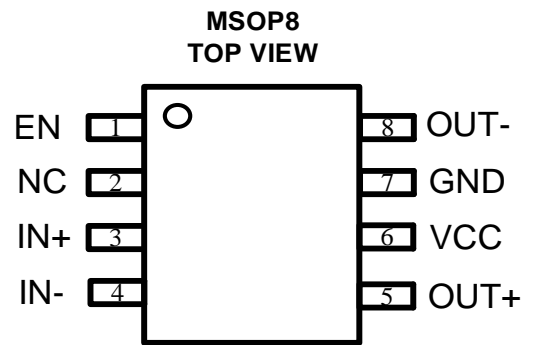
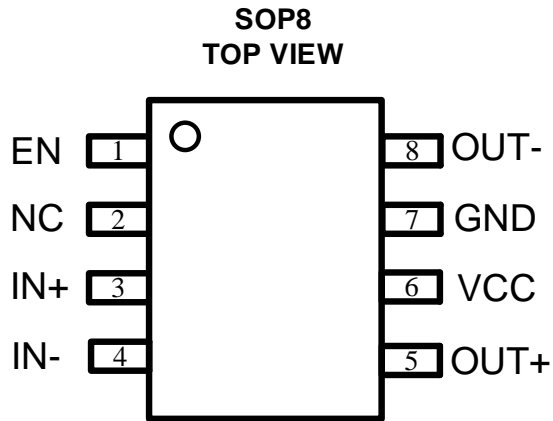

PIN DESCRIPTIONS

PIN	NAME	FUNCTION
1	EN	Chip enable pin, active high
2	NC	Not connection
3	IN+	Positive audio input pin
4	IN-	Negative audio input pin
5	OUT+	Positive audio output pin
6	VCC	Power supply
7	GND	Ground
8	OUT-	Negative audio output pin

BLOCK DIAGRAM

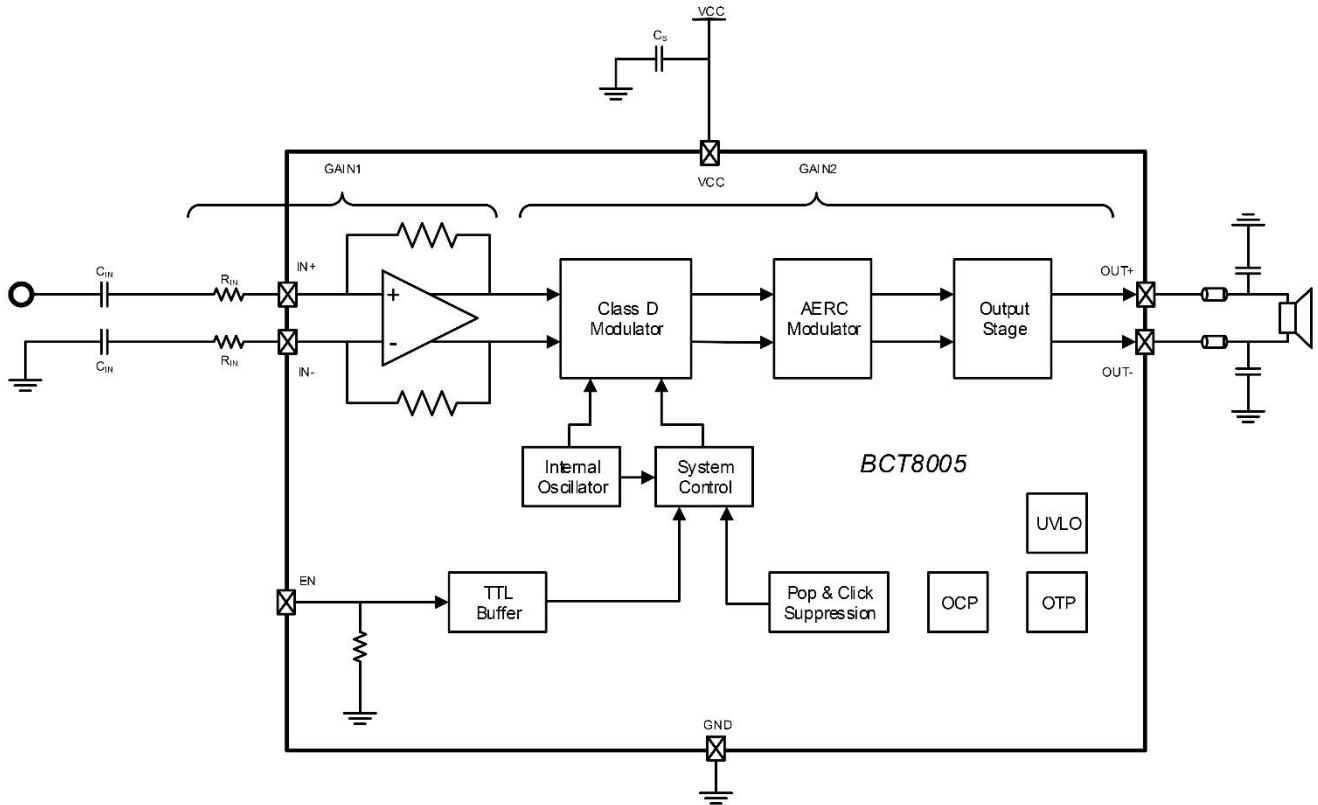

TYPICAL APPLICATION CIRCUIT

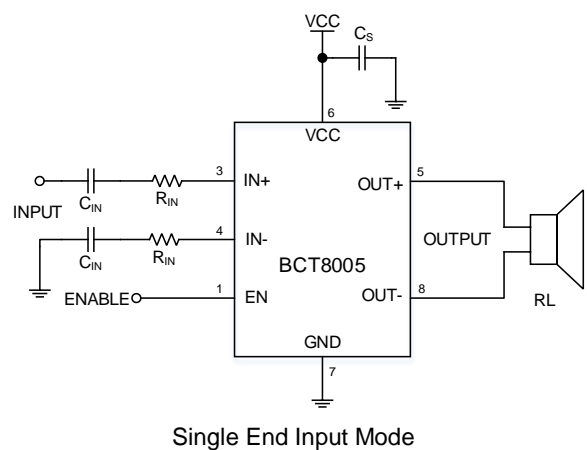
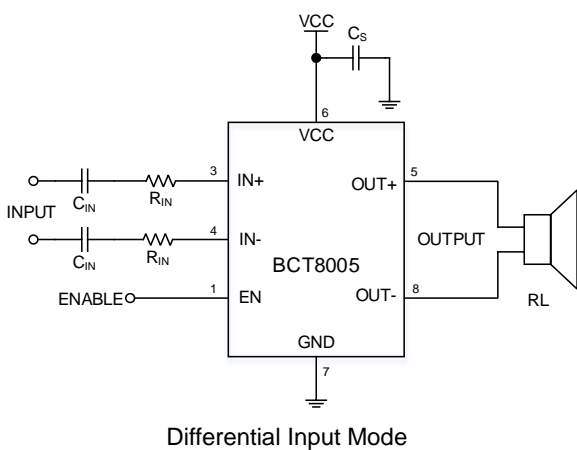

Note: $Gain = 2 \times 150k / R_{IN}$



BCT8005

2.8W Mono Class D Audio Power Amplifier

ABSOLUTE MAXIMUM RATINGS

VCC, EN Supply Voltage Range.....	-0.3V to 6V
IN+, IN- Input Voltage Range.....	-0.3V to VCC+0.3V
Package Thermal Resistance θ_{JA}	
SOP8.....	165°C/W
MSOP8.....	215°C/W
DFN2x2-8L.....	140°C/W
Operating Temperature Range.....	-40°C to +85°C
Junction Temperature.....	150°C
Storage Temperature Range.....	-65°C to +150°C
Lead Temperature (Soldering, 10sec).....	260°C
ESD HBM (human body model)	±6KV

NOTE:

- Stresses beyond those listed under "Absolute Maximum Ratings" may cause permanent damage to the device. These are stress ratings only and functional operation of the device at these or any other conditions beyond those indicated in the operational sections of the specifications is not implied. Exposure to absolute Maximum rating conditions for extended periods may affect device reliability.

RECOMMENDED OPERATING CONDITONS

The Recommended Operating Conditions table defines the conditions for actual device operation. Recommended operating conditions are specified to ensure optimal performance to the datasheet specifications.

Symbol	Parameter	Min.	Max.	Unit
V _{CC}	Supply Voltage	2.8	5.5	V
T _A	Operating Temperature	-40	+85	°C
T _J	Junction Temperature	-40	+125	°C

ELECTRICAL CHARACTERISTICS

$T_A=25^{\circ}\text{C}$, $V_{CC}=3.6\text{V}$, $R_L=8\Omega+33\mu\text{H}$, $f=1\text{kHz}$ (unless otherwise noted)

Symbol	Parameter	Test Conditions	Min	Typ	Max	Units
V _{oo}	Output Offset Voltage	V _{IN} =0V, A _V =2V/V, V _{CC} =2.8V to 5.5V		5	25	mV
PSRR	Power Supply Ripple Rejection	V _{CC} =2.8V to 5.5V, f=217Hz		-80		dB
I _{IH}	Input High Current	V _{CC} =5.5V, V _I = V _{CC}			50	μA
I _{IL}	Input Low Current	V _{CC} =5.5V, V _I =0V			1	μA
I _{DD}	Quiescent Current	V _{CC} =5.5V, No load, No Filter		3.6		mA
		V _{CC} =3.6V, No load, No Filter		2		mA
I _{SD}	Shutdown Current	EN=0V		0.1		μA
R _{DS(ON)}	Static Drain to Source On-state Resistor	V _{CC} =5.0V		260		mΩ
f _(SW)	Switching Frequency	V _{CC} =2.8V to 5.5V		700		kHz
Gain	Closed-loop Gain			(2x150kΩ)/R _{in}		V/V
R _{SD}	Shutdown Pull-down Resistor			230		KΩ
V _{IH}	EN Input High Voltage	V _{CC} =2.8V to 5.5V	1.4			V
V _{IL}	EN Input LOW Voltage	V _{CC} =2.8V to 5.5V			0.4	V

OPERATING CHARACTERISTICS

Symbol	Parameter	Test Conditions	Min	Typ	Max	Units	
P _o	Output Power	THD=10%, f=1kHz, R _L =4Ω	V _{CC} =5.0V		2.8		W
			V _{CC} =3.6V		1.4		W
		THD=1%, f=1kHz, R _L =4Ω	V _{CC} =5.0V		2.2		W
			V _{CC} =3.6V		1.1		W
		THD=10%, f=1kHz, R _L =8Ω	V _{CC} =5.0V		1.66		W
			V _{CC} =3.6V		0.8		W
THD=1%, f=1kHz, R _L =8Ω	V _{CC} =5.0V		1.3		W		
	V _{CC} =3.6V		0.62		W		
THD+N	Total Harmonic Distortion Plus Noise	P _o =0.6W, f=1kHz, R _L =8Ω	V _{CC} =5.0V		0.11		%
		P _o =0.4W, f=1kHz, R _L =8Ω	V _{CC} =4.2V		0.13		%
		P _o =0.4W, f=1kHz, R _L =8Ω	V _{CC} =3.6V		0.15		%
η	Efficiency	P _o =1.0W, f=1kHz, R _L =8Ω	V _{CC} =5.0V		90		%
t _{ST}	Start Time			40		ms	

PERFORMANCE CHARACTERISTICS

Test condition: $T_A=25^\circ\text{C}$, $V_{CC}=3.6\text{V}$, $R_L=8\Omega+33\mu\text{H}$, $f=1\text{kHz}$ (unless otherwise noted)

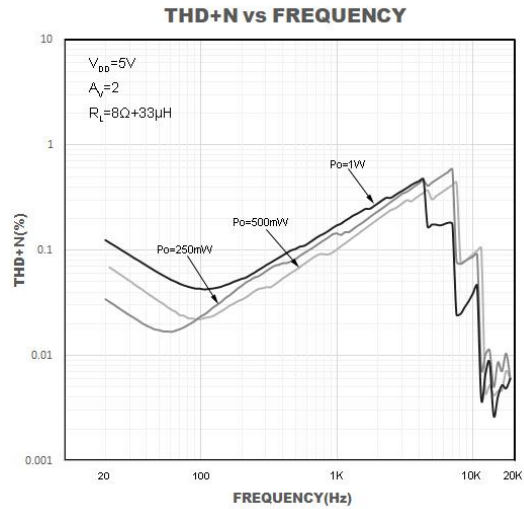
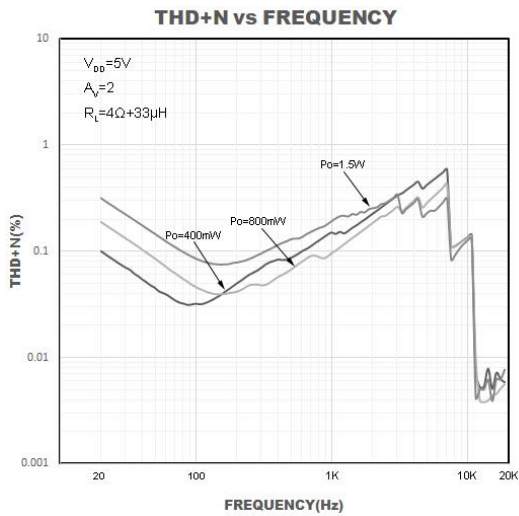
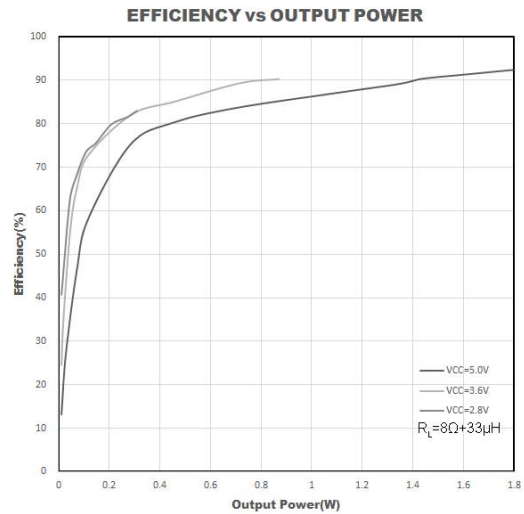
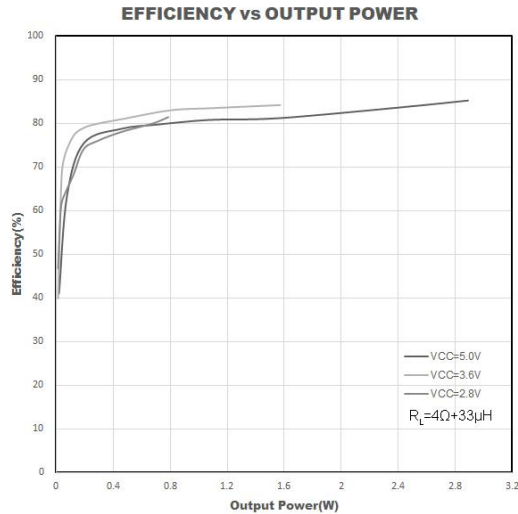

PERFORMANCE CHARACTERISTICS (continued)

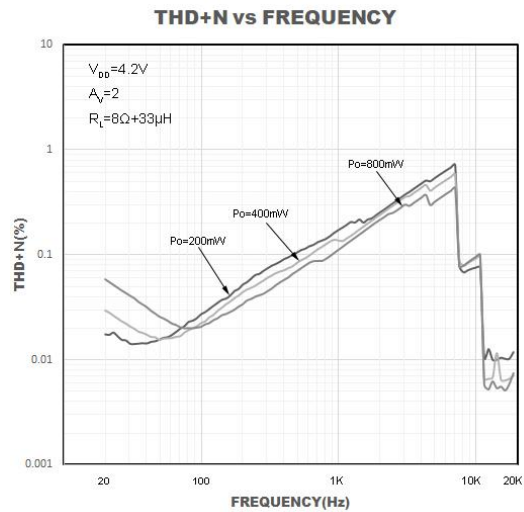
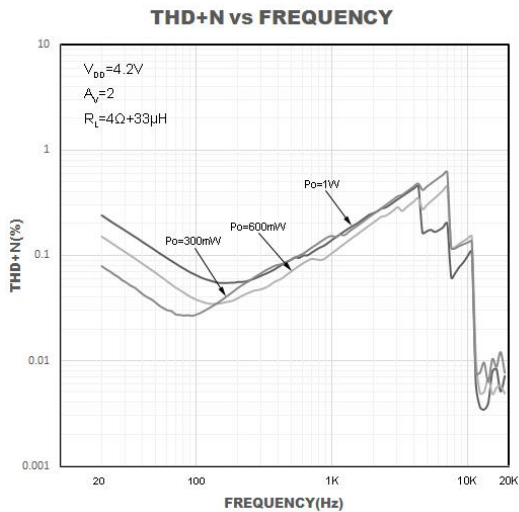
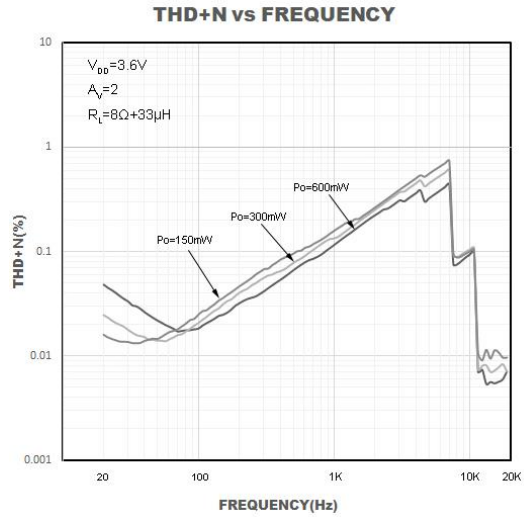
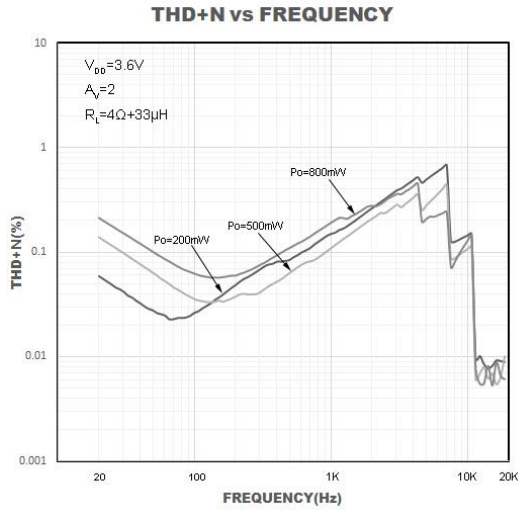

APPLICATION INFORMATION

Input Capacitors (C_{IN})

In the typical application, an input capacitor C_{IN}, is required to allow the amplifier to bias the input signal to the proper DC level for optimum operation. In this case, C_{IN} and the minimum input impedance R_{IN} form a high-pass filter with the corner frequency determined in the following equation:

$$f_c = \frac{1}{(2\pi R_{IN} C_{IN})}$$

It is important to consider the value of C_{IN} as it directly affects the low frequency performance of the circuit. For example, when R_{IN} is 150kΩ and the specification calls for a flat bass response are down to 150Hz. Equation is reconfigured as followed:

$$C_{IN} = \frac{1}{(2\pi R_{IN} f_c)}$$

Input Resistance (R_{IN})

The BCT8005 is a differential audio amplifier. The IC integrates two internal input resistors which are 150kΩ. Change external input resistor R_{IN} to setup system gain. Equation is configured as followed:

$$GAIN = \frac{2 \times 150k\Omega}{R_{IN}}$$

Decoupling Capacitor (C_S)

The optimum decoupling is achieved by using two different types of capacitors that target on different types of noise on the power supply leads. For higher frequency transients, spikes, or digital hash on the line, a good low equivalent-series-resistance (ESR) ceramic capacitor, typically 1μF. For filtering lower frequency noise signals, a large ceramic capacitor of 10μF or greater placed near the audio power amplifier is recommended.

How to Reduce EMI

The ferrite filter and capacitor reduce EMI. They are placed as close as possible to the chip for the best operation.

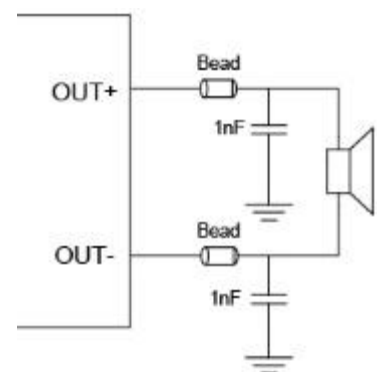

PACKAGE OUTLINE DIMENSIONS (All dimensions in mm.)

SOP8

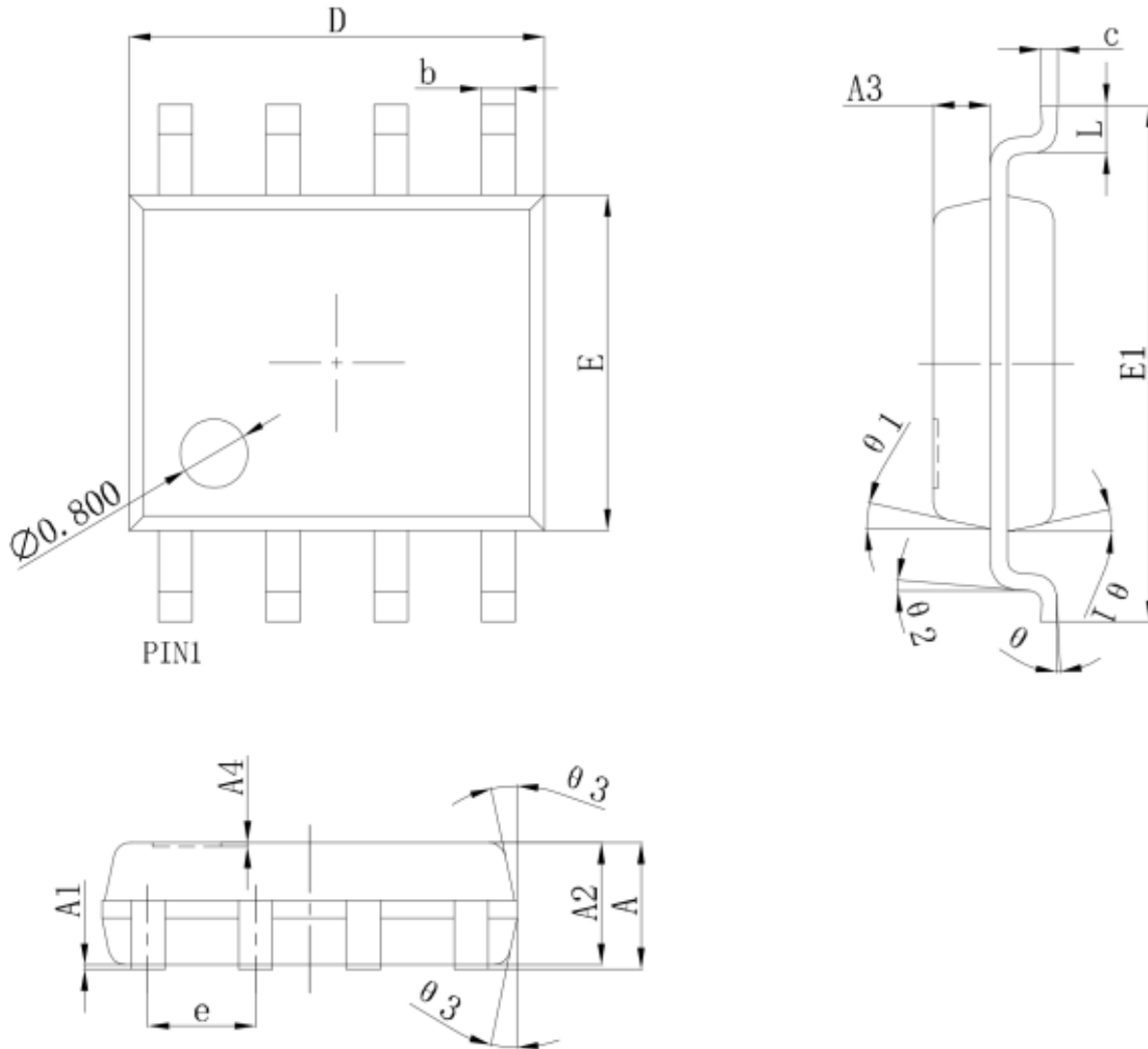

SYMBOL	MILLIMETER			SYMBOL	MILLIMETER		
	MIN	NOM	MAX		MIN	NOM	MAX
A	1.300	1.500	1.700	L	0.450	0.600	0.750
A1	0.100	0.150	0.200	b	0.330	0.400	0.510
A2	1.350	1.420	1.550	D	4.800	4.900	5.000
A3	0.645	0.670	0.695	e	1.270BSC		
A4	0.020	--	0.050	θ	0°	3°	8°
c	0.170	0.203	0.250	θ1	12° REF.		
E	3.800	3.900	4.000	θ2	5° REF.		
E1	5.800	6.000	6.200	θ3	12° REF.		

PACKAGE OUTLINE DIMENSIONS (continued)

MSOP8

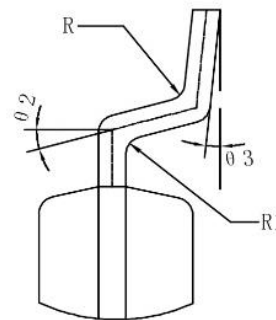
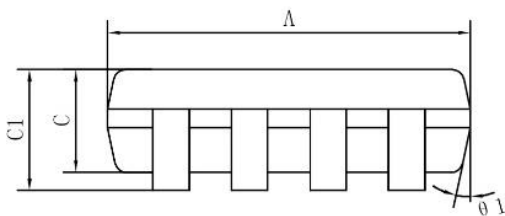
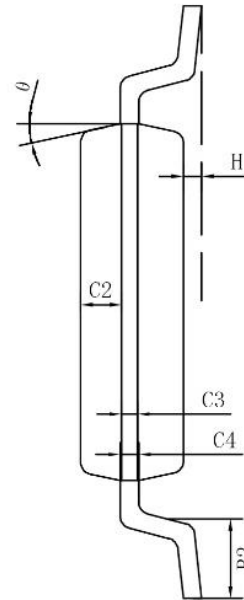
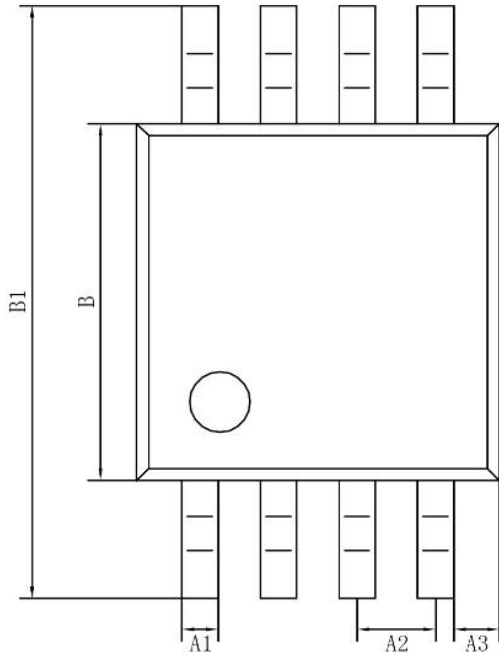

SYMBOL	MIN	NOM	MAX	SYMBOL	MIN	NOM	MAX
A	2.90	3.00	3.10	C3	0.152		
A1	0.28	0.315	0.35	C4	0.15	0.19	0.23
A2	0.65TYP			H	0.00	0.045	0.09
A3	0.375TYP			θ	12°TYP4		
B	2.90	3.10	3.10	$\theta 1$	12°TYP4		
B1	4.70	4.90	5.10	$\theta 2$	14°TYP		
B2	0.45	0.60	0.75	$\theta 3$	0°~ 6°		
C	0.75	0.85	0.95	R	0.15TYP		
C1	-	-	1.10	R1	0.15TYP		
C2	0.328TYP						

PACKAGE OUTLINE DIMENSIONS (continued)

DFN2x2-8L

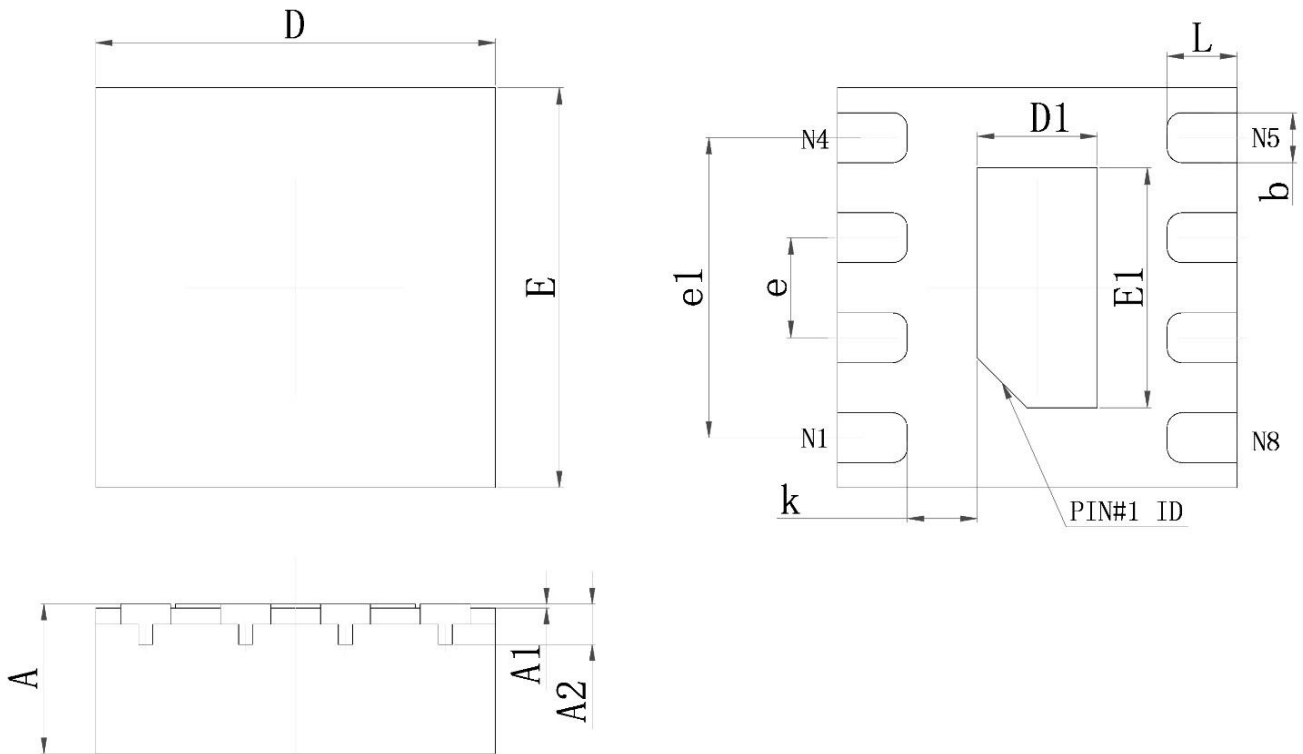

SYMBOL	MIN	NOM	MAX	SYMBOL	MIN	NOM	MAX
A	0.700	0.750	0.800	E1	1.150	1.200	1.250
A1	0.000	0.025	0.050	b	0.200	0.250	0.300
A2	0.203REF.			e	0.500BSC.		
D	1.924	2.000	2.076	e1	1.450	1.500	1.550
E	1.924	2.000	2.076	k	0.300	0.350	0.400
D1	0.550	0.600	0.650	L	0.300	0.350	0.400

单击下面可查看定价，库存，交付和生命周期等信息

[>>Broadchip\(广芯电子\)](#)