

■ 高 Q 片式多层陶瓷电容器 General series of ceramic chip capacitors

◆ 特征

Feature

- * 叠层独石结构，具有高可靠性
There is high reliability on monolithic structure of laminated layers.
- * 具有优良的焊接与耐焊性能，适用于回流焊接与波峰焊接
And its character of excellent soldering ability and soldering resistance ability is suitable for reflow soldering and peak soldering.
- * 具有较高的容量且容量性能稳定
It includes high and stable capacitance.
- * 高 Q 值
High Q
- * 低等效串联电阻
Low equivalent series resistance
- * 执行标准：GB/T 21041-2007
Executive Standard: GB/T 21041-2007

◆ 应用

Application

- * 通讯设备
Communication devices
- * 射频功率放大器
RF power amplifier
- * 滤波网络
Filter network



◆型号表示法
How To Order

0402	HQ	1R0	A	500	N	T																															
尺寸规格 Size Code			标称容量 Nominal Capacitance		额定电压 Rated Voltage 单位(unit): V																																
<table border="1"> <tr> <th>尺寸规格 Size Code</th> <th>长×宽 (L×W) inch</th> <th>长×宽 (L×W) mm</th> </tr> <tr> <td>0201</td> <td>0.02×0.01</td> <td>0.60×0.30</td> </tr> <tr> <td>0402</td> <td>0.04×0.02</td> <td>1.00×0.50</td> </tr> <tr> <td>0603</td> <td>0.06×0.03</td> <td>1.60×0.80</td> </tr> <tr> <td>0805</td> <td>0.08×0.05</td> <td>2.00×1.25</td> </tr> </table>	尺寸规格 Size Code	长×宽 (L×W) inch	长×宽 (L×W) mm	0201	0.02×0.01	0.60×0.30	0402	0.04×0.02	1.00×0.50	0603	0.06×0.03	1.60×0.80	0805	0.08×0.05	2.00×1.25	<table border="1"> <tr> <th>表示方式 Express Method</th> <th>实际值 Actual Value</th> </tr> <tr> <td>0R5</td> <td>0.5</td> </tr> <tr> <td>1R0</td> <td>1.0</td> </tr> <tr> <td>102</td> <td>10×10²</td> </tr> </table> <p>注：头两位数字为有效数字，第三位数字为0的个数；R为小数点。 Note: the first two digits are significant; third digit denotes number of zeros; R=decimal point.</p>		表示方式 Express Method	实际值 Actual Value	0R5	0.5	1R0	1.0	102	10×10 ²	<table border="1"> <tr> <th>表示方式 Express Method</th> <th>实际值 Actual Value</th> </tr> <tr> <td>6R3</td> <td>6.3</td> </tr> <tr> <td>500</td> <td>50×10⁰</td> </tr> <tr> <td>201</td> <td>20×10¹</td> </tr> </table> <p>注：头两位数字为有效数字，第三位数字为0的个数；R为小数点。 Note: the first two digits are significant; third digit denotes number of zeros; R=decimal point.</p>		表示方式 Express Method	实际值 Actual Value	6R3	6.3	500	50×10 ⁰	201	20×10 ¹	包装方式 Package Styles	
尺寸规格 Size Code	长×宽 (L×W) inch	长×宽 (L×W) mm																																			
0201	0.02×0.01	0.60×0.30																																			
0402	0.04×0.02	1.00×0.50																																			
0603	0.06×0.03	1.60×0.80																																			
0805	0.08×0.05	2.00×1.25																																			
表示方式 Express Method	实际值 Actual Value																																				
0R5	0.5																																				
1R0	1.0																																				
102	10×10 ²																																				
表示方式 Express Method	实际值 Actual Value																																				
6R3	6.3																																				
500	50×10 ⁰																																				
201	20×10 ¹																																				
介质种类 Dielectric Code			容量误差 Capacitance Tolerance			终端材料 Terminal Material Styles																															
<table border="1"> <tr> <th>介质种类 Dielectric Code</th> <th>介质材料 Dielectric</th> </tr> <tr> <td>HQ</td> <td>C0G</td> </tr> </table>			介质种类 Dielectric Code	介质材料 Dielectric	HQ	C0G	<table border="1"> <tr> <th>代码 Code</th> <th>误差 Tolerance</th> <th>备注 Note</th> </tr> <tr> <td>A</td> <td>±0.05pF</td> <td rowspan="6">A、B、C、D级误差适用于容量≤10pF的产品。 These Capacitance tolerance A, B, C, D are just applicable the capacitance that equals to or less than 10pF.</td> </tr> <tr> <td>B</td> <td>±0.10pF</td> </tr> <tr> <td>C</td> <td>±0.25pF</td> </tr> <tr> <td>D</td> <td>±0.50pF</td> </tr> <tr> <td>F</td> <td>±1%</td> </tr> <tr> <td>J</td> <td>±5%</td> </tr> </table>			代码 Code	误差 Tolerance	备注 Note	A	±0.05pF	A、B、C、D级误差适用于容量≤10pF的产品。 These Capacitance tolerance A, B, C, D are just applicable the capacitance that equals to or less than 10pF.	B	±0.10pF	C	±0.25pF	D	±0.50pF	F	±1%	J	±5%	<table border="1"> <tr> <th>终端类别 Termination Styles</th> <th>表示方式 Express Method</th> </tr> <tr> <td>三层电镀端头 Nickel Barrier Termination</td> <td>N</td> </tr> </table>		终端类别 Termination Styles	表示方式 Express Method	三层电镀端头 Nickel Barrier Termination	N						
介质种类 Dielectric Code	介质材料 Dielectric																																				
HQ	C0G																																				
代码 Code	误差 Tolerance	备注 Note																																			
A	±0.05pF	A、B、C、D级误差适用于容量≤10pF的产品。 These Capacitance tolerance A, B, C, D are just applicable the capacitance that equals to or less than 10pF.																																			
B	±0.10pF																																				
C	±0.25pF																																				
D	±0.50pF																																				
F	±1%																																				
J	±5%																																				
终端类别 Termination Styles	表示方式 Express Method																																				
三层电镀端头 Nickel Barrier Termination	N																																				
<table border="1"> <tr> <th>表示方式 Express Method</th> <th>包装方式 Package Styles</th> </tr> <tr> <td>B</td> <td>散包装 Bulk Bag</td> </tr> <tr> <td>T</td> <td>编带包装 Taping Package</td> </tr> </table>			表示方式 Express Method	包装方式 Package Styles	B	散包装 Bulk Bag	T	编带包装 Taping Package																													
表示方式 Express Method	包装方式 Package Styles																																				
B	散包装 Bulk Bag																																				
T	编带包装 Taping Package																																				

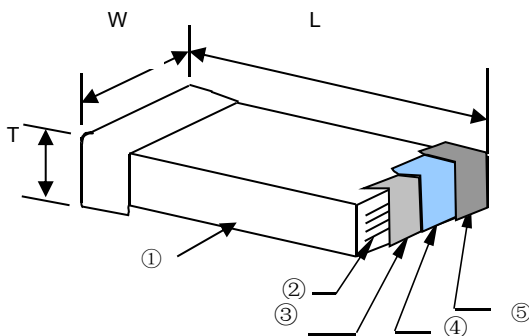
◆产品结构
Product Structure

序号 NO	名称 Name
①	陶瓷介质 Ceramic dielectric
②	内电极 Inner electrode
③	外电极 Substrate electrode
④	镍层 Nickel Layer
⑤	锡层 Tin Layer

◆ 产品尺寸 Product Dimensions

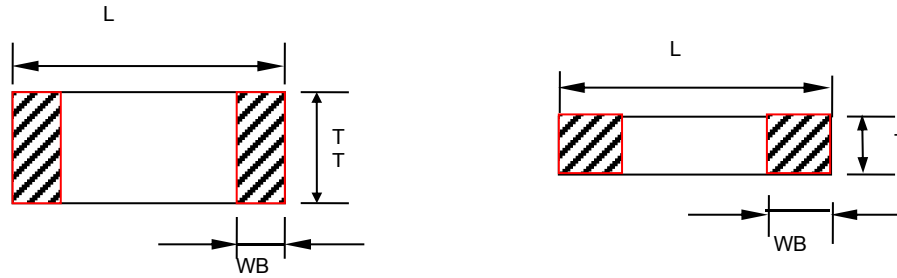

型号 Type		尺寸 Dimensions (mm)			
英制表示 British expression	公制表示 Metric expression	L	W	T	WB
0201	0603	0.60±0.03	0.30±0.03	0.30±0.03	0.15±0.05
0402	1005	1.00±0.05	0.50±0.05	0.50±0.05	0.25±0.05
0603	1608	1.60±0.10	0.80±0.10	0.80±0.10	0.35±0.20
0805	2012	2.00±0.20	1.25±0.20	0.80±0.20	0.50±0.20

备注：可根据客户的特殊要求设计符合客户需求的产品。

Note: We can design according to customer special requirements

◆ 温度系数/特性 Temperature Coefficient /Characteristics

介质种类 Dielectric	参考温度点 Reference Temperature Point	标称温度系数 Temperature Coefficient	工作温度范围 Operation Temperature Range
C0G	20°C	0±30ppm/°C	-55°C~125°C

◆ 容量范围及其电压 Capacitance Range and Operating Voltage

介质种类 Dielectric	C0G											
	0201		0402		0603				0805			
尺寸 Dimensions												
电压 Voltage	25V	50V	25V	50V	25V	50V	100V	200/250V	25V	50V	100V	200/250V
电容量 Capacitance												
0.1pF												
0.2pF												
0.3pF												
0.4pF												
0.5pF												
0.6 pF												
0.7pF												
1.0pF												
1.2pF												
1.5pF												
1.8pF												
2.0pF												
2.2pF												
3.3pF												
3.9pF												
4.7pF												
5.6pF												



备注：1、  正常产品

2、可根据客户的特殊要求设计符合客户需求的产品

Note: 1、  Normal production

2、We can design according to the customer requirements.

介质种类 Dielectric	COG											
尺寸 Dimensions	0201		0402		0603				0805			
电压 Voltage	25V	50V	25V	50V	25V	50V	100V	200/250V	25V	50V	100V	200/250V
电容量 Capacitance												
6.8pF												
8.2pF												
10pF												
12pF												
15pF												
18pF												
22pF												
27pF												
33pF												
39pF												
47pF												
56pF												
68pF												
82pF												
100pF												
120pF												
150pF												
180pF												
220pF												
270pF												
330pF												
390pF												
470pF												
560pF												
680pF												
820pF												
1000pF												
1200pF												
1500pF												

备注：1、 正常产品 2、可根据客户的特殊要求设计符合客户需求的产品
 Note: 1、 Normal production 2、We can design according to the customer requirements.

◆ 可靠性测试 Reliability Test

项目 Item	技术规格 Technical Specification	测试方法 Test Method and Remarks		
容量 Capacitance	应符合指定的误差级别 Should be within the specified tolerance.	标称容量 Capacitance	测试频率 Measuring Frequency	测试电压 Measuring Voltage
		≤1000pF	1MHz±10%	1.0±0.2Vrms
		> 1000 pF	1KHz±10%	
Q	C≥30pF, Q≥1000 C≤30pF, Q≥400+20C	测试频率：1MHz±10% 测试电压：1.0±0.2Vrms Test Frequency: 1MHz±10% Test Voltage: 1.0±0.2Vrms		

项目 Item	技术规格 Technical Specification		测试方法 Test Method and Remarks	
绝缘电阻 (IR) Insulation Resistance	$\geq 10,000\text{M}\Omega$		测试电压：额定电压 测试时间：60±5 秒 测试湿度：≤75% 测试温度：25℃±3℃ 测试充放电电流：≤50mA Measuring Voltage: Rated Voltage (Max 500V) Duration: 60±5s Test Humidity: ≤75% Test Temperature: 25℃±3℃ Test Current: ≤50mA	
介电强度 (DW) Dielectric Withstanding Voltage	不应有介质被击穿或损伤。 No breakdown or damage.		测量电压：I类：300%额定电压 时间：1~5 秒 充/放电电流：不应超过 50mA Measuring Voltage: Class I :300% Rated voltage Duration: 1~5s Charge/ Discharge Current: 50mA max.	
可焊性 Solderability	上锡率应大于 95% 外观：无可见损伤。 At least 95% of the terminal electrode is covered by new solder. Visual Appearance: No visible damage.		将电容在 80~120℃的温度下预热 10~30 秒。 Preheating conditions:80 to 120℃; 10~30s.	
			<table border="1"> <tr> <td>有铅焊料：(Sn/Pb: 63/37) 浸锡温度：235±5℃ 浸锡时间：2±0.5s Solder Temperature: 235±5℃ Duration: 2±0.5s</td> <td>无铅焊料： 浸锡温度：245±5℃ 浸锡时间：2±0.5s Solder Temperature: 245±5℃ Duration: 2±0.5s</td> </tr> </table>	有铅焊料：(Sn/Pb: 63/37) 浸锡温度：235±5℃ 浸锡时间：2±0.5s Solder Temperature: 235±5℃ Duration: 2±0.5s
有铅焊料：(Sn/Pb: 63/37) 浸锡温度：235±5℃ 浸锡时间：2±0.5s Solder Temperature: 235±5℃ Duration: 2±0.5s	无铅焊料： 浸锡温度：245±5℃ 浸锡时间：2±0.5s Solder Temperature: 245±5℃ Duration: 2±0.5s			
耐焊接热 Resistance to Soldering Heat	$\Delta C/C$	在±0.5%或±0.5pF范围内，取较大值 Within ±0.5% or ±0.5pF, whichever is larger	将电容在 100~200℃的温度下预热 10±2 分钟。 浸锡温度：265±5℃ 浸锡时间：10±1s 然后取出溶剂清洗干净，在 10 倍以上的显微镜底下观察。 放置时间：24±2 小时 放置条件：室温 Preheating conditions: 100 to 200℃; 10±2min. Solder Temperature: 265±5℃ Duration: 10±1s Clean the capacitor with solvent and examine it with a 10X(min.) microscope. Recovery Time: 24±2h Recovery condition: Room temperature	
	Q	同初始标准 Same to initial value.		
	IR	同初始标准 Same to initial value.		
	外观：无可见损伤 上锡率：≥95% Appearance: No visible damage. At least 95% of the terminal electrode is covered by new solder.			
抗弯曲强度 Resistance to Flexure of Substrate (Bending Strength)	外观：无可见损伤。 Appearance: No visible damage.		试验基板：Al ₂ O ₃ 或 PCB 弯曲深度：1mm 施压速度：1mm/sec. 单位：mm 应在弯曲状态下进行测量。 Test Board: Al ₂ O ₃ or PCB Warp: 1mm Speed: 1mm/sec. Unit: mm The measurement should be made with the board in the bending position.	
	$\Delta C/C$	在±0.5%或±0.5pF范围内，取较大值 Within ±0.5% or ±0.5pF, whichever is larger		
端子结合强度 Termination Adhesion	外观无可见损伤 No visible damage.		施加的力：5N 时间：10±1S Applied Force: 5N Duration: 10±1S	

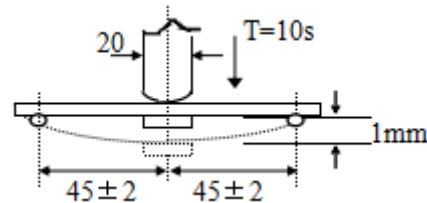

项目 Item	技术规格 Technical Specification	测试方法 Test Method and Remarks															
温度循环 Temperature Cycle	项目 Item	COG															
	$\Delta C/C$	$\leq \pm 1\%$ 或 $\pm 1\text{pF}$, 取较大值 $\leq \pm 1\%$ or $\pm 1\text{pF}$, whichever is larger															
	Q	同初始标准 Same to initial value.															
	IR	同初始标准 Same to initial value.															
		初始测量 Initial Measurement 循环次数: 5次, 一个循环分以下4步: Cycling Times: 5 times, 1 cycle, 4 steps: <table border="1"> <thead> <tr> <th>阶段 Step</th> <th>温度 (Temperature) ($^{\circ}\text{C}$)</th> <th>时间 (Time)</th> </tr> </thead> <tbody> <tr> <td>1</td> <td>下限温度(Low- category temp.): (NPO: -55)</td> <td>30min</td> </tr> <tr> <td>2</td> <td>常温 (Normal temp.): $+20^{\circ}\text{C}$</td> <td>2~3min</td> </tr> <tr> <td>3</td> <td>上限温度 (Up- category temp.) (NPO: $+125$)</td> <td>30min</td> </tr> <tr> <td>4</td> <td>常温 (Normal temp.): $+20^{\circ}\text{C}$</td> <td>2~3min</td> </tr> </tbody> </table> 试验后放置 (恢复) 时间: $24 \pm 2\text{h}$ Recovery time after test: $24 \pm 2\text{h}$	阶段 Step	温度 (Temperature) ($^{\circ}\text{C}$)	时间 (Time)	1	下限温度(Low- category temp.): (NPO: -55)	30min	2	常温 (Normal temp.): $+20^{\circ}\text{C}$	2~3min	3	上限温度 (Up- category temp.) (NPO: $+125$)	30min	4	常温 (Normal temp.): $+20^{\circ}\text{C}$	2~3min
阶段 Step	温度 (Temperature) ($^{\circ}\text{C}$)	时间 (Time)															
1	下限温度(Low- category temp.): (NPO: -55)	30min															
2	常温 (Normal temp.): $+20^{\circ}\text{C}$	2~3min															
3	上限温度 (Up- category temp.) (NPO: $+125$)	30min															
4	常温 (Normal temp.): $+20^{\circ}\text{C}$	2~3min															
耐湿负荷 Humidity load	$\Delta C/C$	I类: $\pm 7.5\%$ 或 $\pm 0.75\text{pF}$, 取两者之中较大者 Class I: $\pm 7.5\%$ or $\pm 0.75\text{pF}$, whichever is larger.															
	Q	≤ 2 倍初始标准 Not more than twice of initial value.															
	IR	$R_i \geq 1000\text{M}\Omega$															
	外观: 无损伤 Appearance: No visible damage.																
		温度: $40 \pm 2^{\circ}\text{C}$ 湿度: 90~95%RH 电压: 额定电压 时间: 500小时 放置条件: 室温 放置时间: 24小时 (I类); 48小时 (II类) Temperature: $40 \pm 2^{\circ}\text{C}$ Humidity: 90~95%RH Voltage: Rated Voltage Duration: 500h Recovery conditions: Room temperature Recovery Time: 24h (Class1) or 48h (Class2)															
寿命试验 Life Test	$\Delta C/C$	COG $\pm 2\%$ 或 $\pm 1\text{pF}$, 取两者之中较大者 $\pm 2\%$ or $\pm 1\text{pF}$, whichever is larger.															
	Q	≤ 2 倍初始标准 Not more than twice of initial value.															
	IR	$R_i \geq 4000\text{M}\Omega$ 或 $R_i \cdot C_r \geq 40\text{S}$ 取两者之中较小者 $R_i \geq 4000\text{M}\Omega$ 或 $R_i \cdot C_r \geq 40\text{S}$ whichever is smaller.															
	外观: 无损伤 Appearance: No visible damage.																
		低压产品 ($< 100\text{V}$) 电压: 2倍额定工作电压, 时间: 1000小时 温度: 125°C 充电电流: 不应超过 50mA 放置条件: 室温 放置时间: 24小时 (I类), 或 48小时 (II类), Low-Voltage ($< 100\text{V}$) Applied Voltage: $2 \cdot U_r$ Duration: 1000h Temperature: 125°C Charge/ Discharge Current: 50mA max. Recovery Conditions: Room Temperature Recovery Time: 24h (Class 1), or 48h (Class2)															

◆ 典型特性曲线 Typical characteristic curve

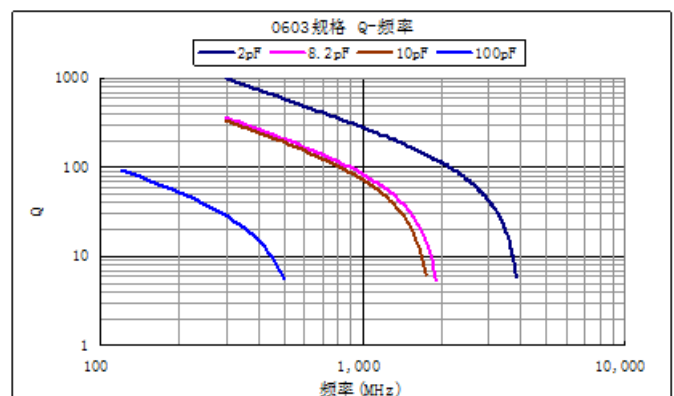
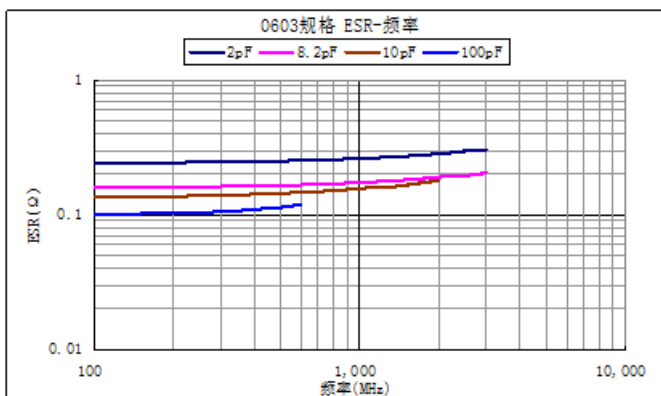

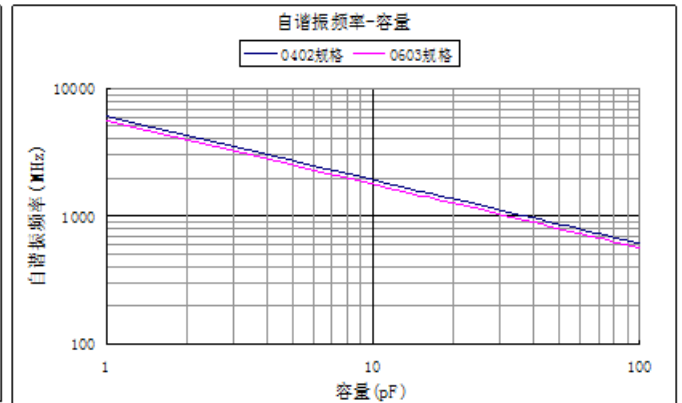
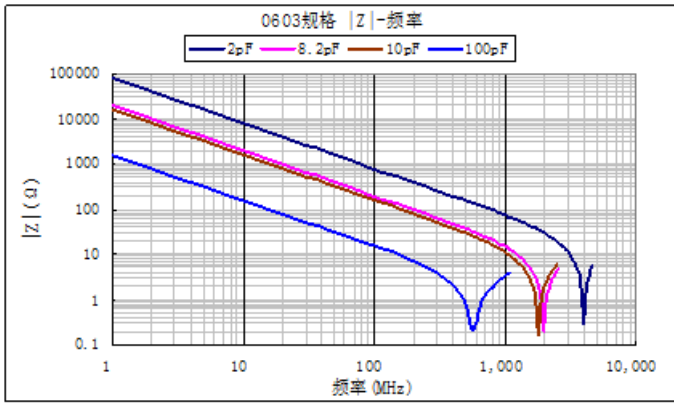

◆ **包装**
Package

* 纸带卷盘结构
Paper Taping

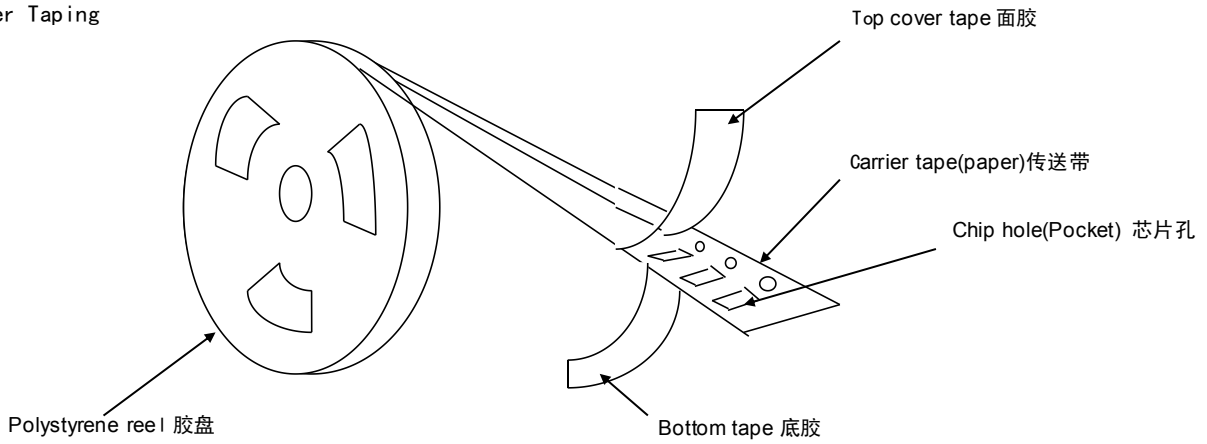

* 0201、0402 纸带编带尺寸大小
Dimensions of paper taping for 0201、0402 type

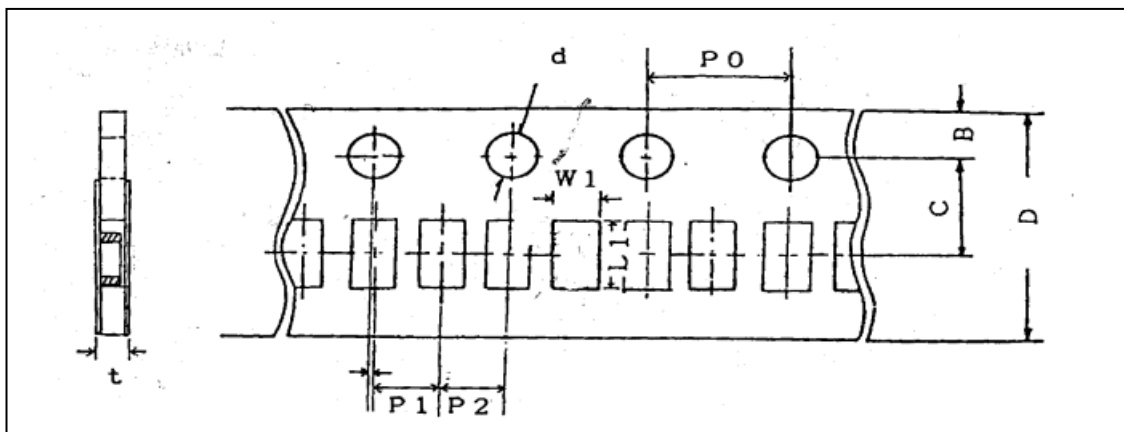

代号 Code	W1	L1	D	C	B	P1	P2	P0	d	t
0201	0.37± 0.10	0.67±0. 10	8.00± 0.10	3.50± 0.05	1.75± 0.10	2.00± 0.05	2.00± 0.05	4.00±0 .10	1.50 -0/+0.10	0.80 Below
0402	0.65± 0.10	1.15± 0.10	8.00± 0.10	3.50± 0.05	1.75± 0.10	2.00± 0.05	2.00± 0.05	4.00±0 .10	1.50 -0/+0.10	0.80 Below

* 适合 '0603, 0805' 常规尺寸产品的纸带尺寸
 Dimensions of paper taping for 0603, 0805 types.

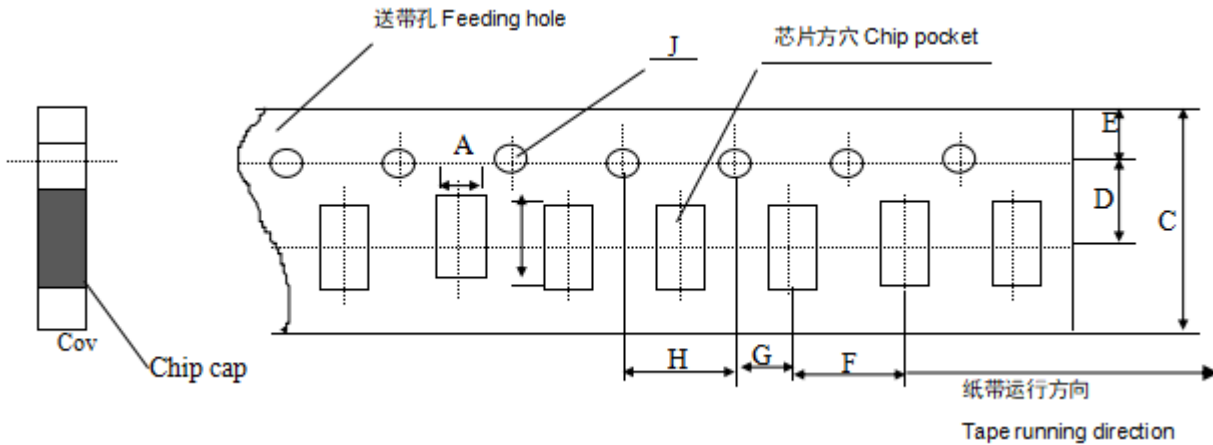

Unit: mm

代号Code 纸带规格 paper size	A	B	C	D*	E	F	G*	H	J	T
0603	1.10 ±0.10	1.90 ±0.10	8.00 ±0.10	3.50 ±0.05	1.75 ±0.10	4.00 ±0.10	2.00 ±0.10	4.00 ±0.10	1.50 -0/+0.10	1.10 Max
0805	1.45 ±0.15	2.30 ±0.15	8.0 ±0.15	3.50 ±0.05	1.75 ±0.10	4.00 ±0.10	2.00 ±0.10	4.00 ±0.10	1.50 -0/+0.10	1.10 Max

注意: *表示此处对尺寸的要求非常精确。
 Note: The place with "*" means where needs exactly dimensions.

* 传送带的前后结构
 Structure of leader part and end part of the carrier paper

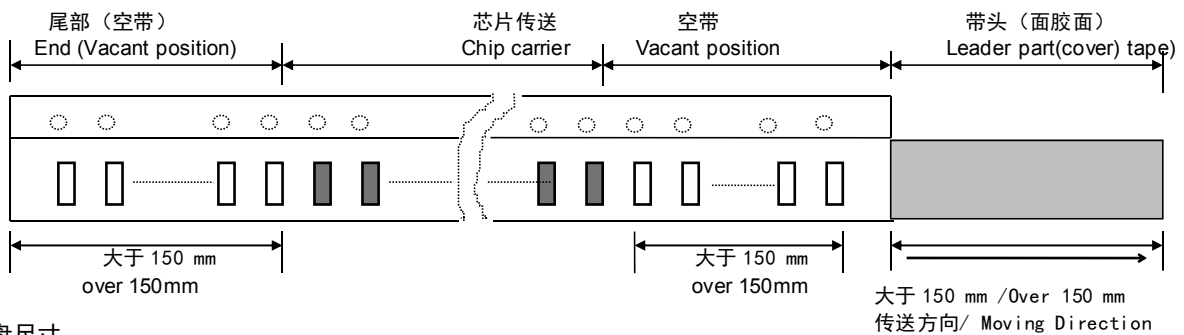

* 卷盘尺寸
 Reel dimensions (unit: mm)

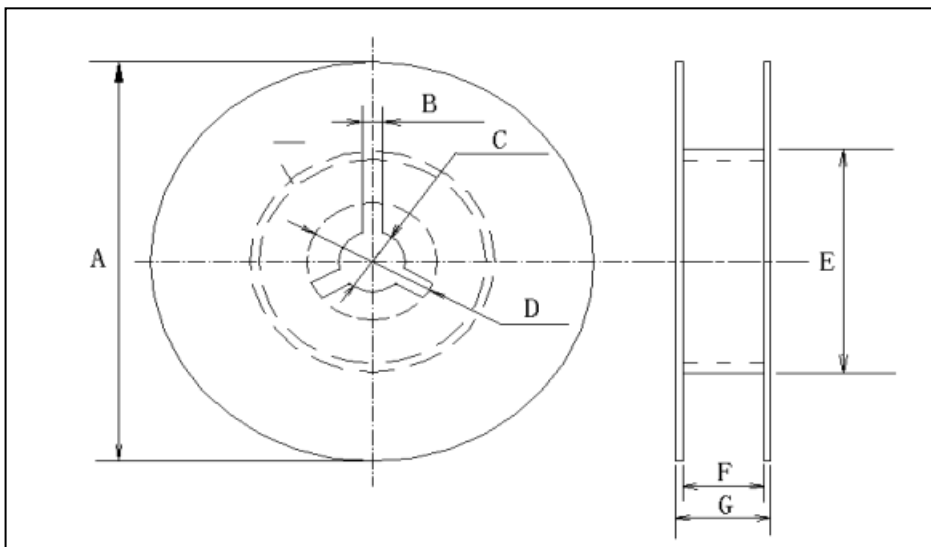

卷盘型号	A	B	C	D	E	F	G
7'REEL	$\phi 178 \pm 2.0$	3.0	$\phi 13 \pm 0.5$	$\phi 21 \pm 0.8$	$\phi 50$ 或更大 $\phi 50$ or more	10.0 ± 1.5	12max
13'REEL	$\phi 330 \pm 2.0$	3.0	$\phi 13 \pm 0.5$	$\phi 21 \pm 0.8$	$\phi 50$ 或更大 $\phi 50$ or more	10.0 ± 1.5	12max

- * 关于卷带的说明：面胶剥离强度
 Taping specification: top tape peeling strength
 纸带 Paper Taping

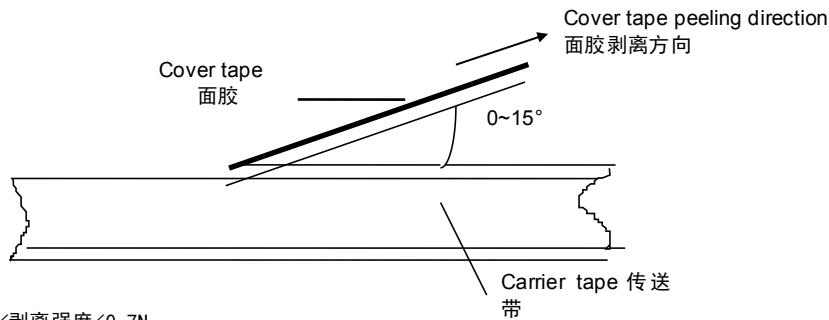

标准：0.1N < 剥离强度 < 0.7N

Standard: 0.1N < peeling strength < 0.7N

在剥离时，纸带不能有纸碎，也不能粘在底、面胶上。

No paper dirty remains on the scotch when peeling, and sticks to top and bottom tape.

- * 包装数量
 Packing Quantity

尺寸 (SIZE)	包装形式和数量 (Package Style & Quantity) unit: pcs				
	塑料压纹带卷盘 (EPT)	纸带卷盘 (PT)	胶带卷盘 (ET)	塑料盒散装 (BC)	一般散装 (BP)
0201	-----	15000	-----	20000	5000
0402	-----	10000	-----	20000	5000
0603	-----	4000	-----	15000	5000
0805	-----	4000	3000	10000	5000

注意：包装的形式和数量可根据客户的要求来定。

Note: We can choose packing style and quantity can be according to the customer's requirement.

- * 外包装
 Outer packing

小包装 The first package
 Quantity: 10 reels
 数量：10 卷

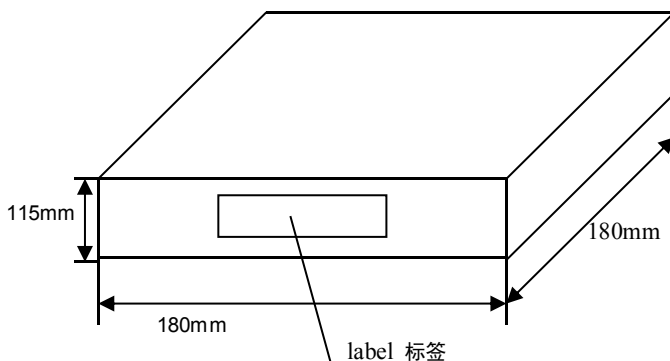

label 标签

PART No 型号规格
QUANTITY 数量
DATE 日期

大包装 The second package
 Quantity: 6 cases
 数量：6 盒

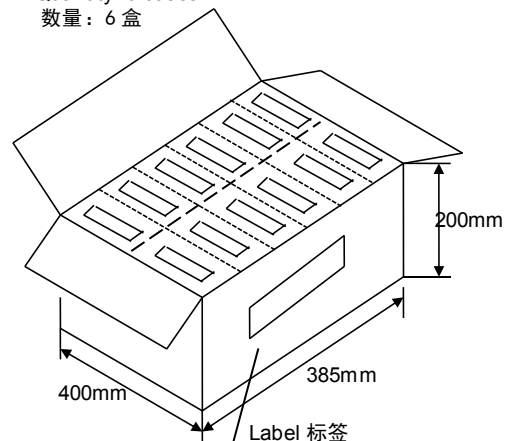

Label 标签

Production name 产品名称
Quantity 数量
Weight 重量

◆ 储存方法

Storage Methods

- * 确保芯片可焊性良好的贮存期限为 12 个月 (在包装好已交付的情况下)。
The guaranteed period for solderability is 12 months (Under deliver package condition).
- * 储存条件 Storage conditions:
 储存温度/Temperature 5~40℃ 储存相对湿度/Relative Humidity 20~70%

◆ 使用前的注意事项

Precautions For Use

多层片式瓷介电容器 (MLCC) 在短路或开路的电路中都有可能失效, 在超出本承诺书或相关说明书中所述使用频率的恶劣工作环境, 或外界机械力超压作用下, 电容芯片都有可能着火、燃烧甚至爆炸, 所以在使用的时候, 首先应考虑按本承诺书的有关说明来进行, 如有不明之处, 请联系我们技术部、品管部或生产部。

The Multi-layer Ceramic Capacitors (MLCC) may fail in a short circuit mode in an open circuit mode when subjected to severe conditions of electrical environment and / or mechanical stress beyond the specified "rating" and specified "conditions" in the specification, which will result in burn out, flaming or glowing in the worst case. Following "precautions for safety" and Application Notes shall be taken in your major consideration. If you have a question about the precautions for handling, please contact our engineering section or factory.

* 焊接的条件与相关图表

Soldering Profile

为避免因温度的突然变化而引起的芯片开裂或局部爆炸的现象发生, 请按有关温度曲线图表来进行。(请参考附页中的图表)

To avoid the crack problem by sudden temperature change, follow the temperature profile in the adjacent graph (refer to the graph in the enclosure page).

* 手工焊接

Manual Soldering

手工焊接很容易因为芯片局部受热不均而引起瓷体微裂或局部爆炸的现象, 在焊接时, 如果操作者不小心, 会使烙铁头直接同电容芯片的瓷体部分接触, 这样很容易使电容芯片因热冲击而受损或出现其他意外。因此, 使用电烙铁手工焊接时应仔细操作, 并对电烙铁的尖端的选择和尖端温度控制应多加小心。

Manual soldering can pose a great risk of creating thermal cracks in capacitors. The hot soldering iron tip comes into direct contact with the end terminations, and operator's careless may cause the tip of the soldering iron to come into direct contact with the ceramic body of the capacitor. Therefore the soldering iron must be handled carefully, and pay much attention to the selection of the soldering iron tip and temperature contact of the tip.

* 适量的焊料

Optimum Solder Amount for Reflow Soldering

焊料过多
Too much solder

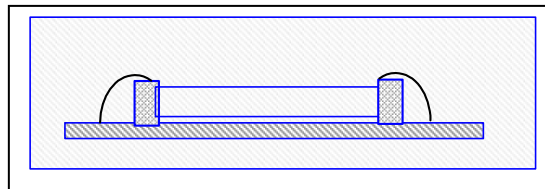

这样会因端头压力过大而可能引起芯片受损
Cracks tend to occur due to large stress.

焊料太少
Not enough solder

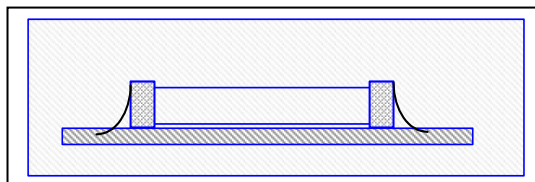

固定力量不足, 可能会引起电容芯片与线路接触不良
Weak holding force may cause badconnection between the capacitor and PCB.

* 推荐焊料用量

Recommended Soldering amounts

回流焊接的最佳焊料用量

The optimal solder fillet amounts for re-flow soldering

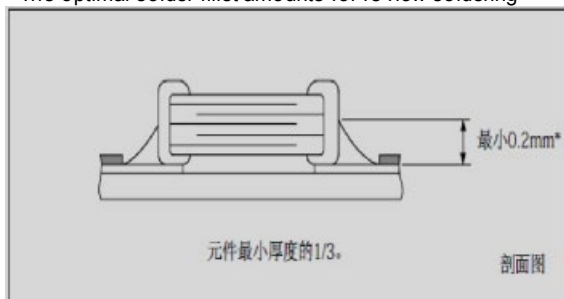

波峰焊接的最佳焊料用量

The optimal solder fillet amounts for wave soldering

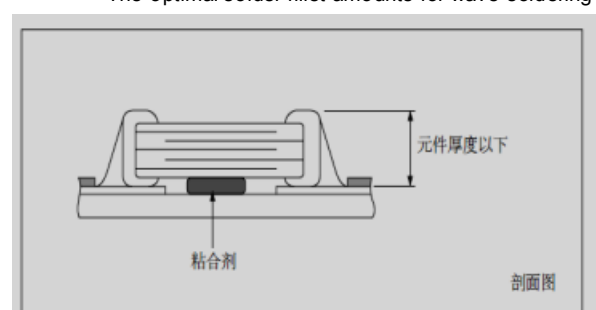

使用烙铁返修时的最佳焊料量

The optimal solder fillet amounts for reworking by using soldering iron

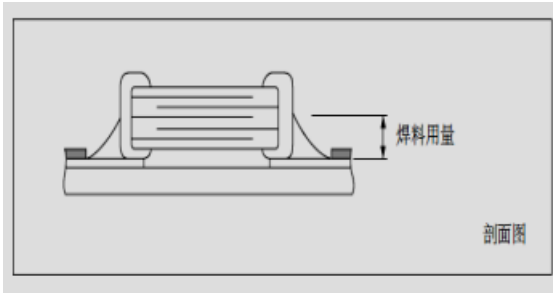

*** 推荐焊接方式**

Recommended Soldering Method

规格尺寸 Size	温度特性 Temperature Characteristics	额定电压 Rated Voltage	容量范围 Capacitance	焊接方式 Soldering Method
0201	NPO	/	/	R
	X7R/X5R/X7S/X6S	/	/	R
	Y5V	/	/	R
0402	NPO	/	/	R
	X7R/X5R/X7S/X6S	/	/	R
	Y5V	/	/	R
0603	NPO	/	/	R/W
	X7R/X5R/X7S/X6S	/	C ≥ 1uf	R
			C < 1uf	R/W
	Y5V	/	C ≥ 1uf	R
C < 1uf			R/W	
0805	NPO	/	/	R/W
	X7R/X5R/X7S/X6S	/	C ≥ 4.7uf	R
			C < 4.7uf	R/W
	Y5V	/	C ≥ 1uf	R
C < 1uf			R/W	

焊接方式 Soldering method:

R—回流焊 Reflow Soldering

W—波峰焊 Wave Soldering

◆ 推荐焊接温度曲线图

The temperature profile for soldering

* 回流焊接 (Re-flow soldering)

	Pb-Sn 焊接 Pb-Sn soldering	无铅焊接 Lead-free soldering
尖峰温度 Peak temperature	230℃~250℃	240℃~260℃

在预热时, 请将焊接温度与芯片表面温度之间的温差维持在 $T \leq 150^\circ\text{C}$ 。

While in preheating, please keep the temperature difference between soldering temperature and surface temperature of chips as: $T \leq 150^\circ\text{C}$.

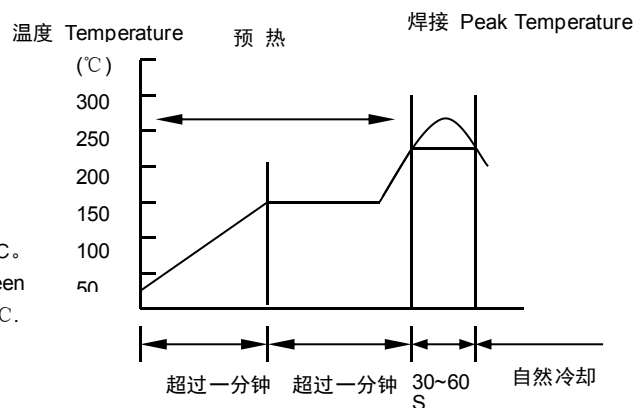

* 波峰焊接
 (Wave soldering)

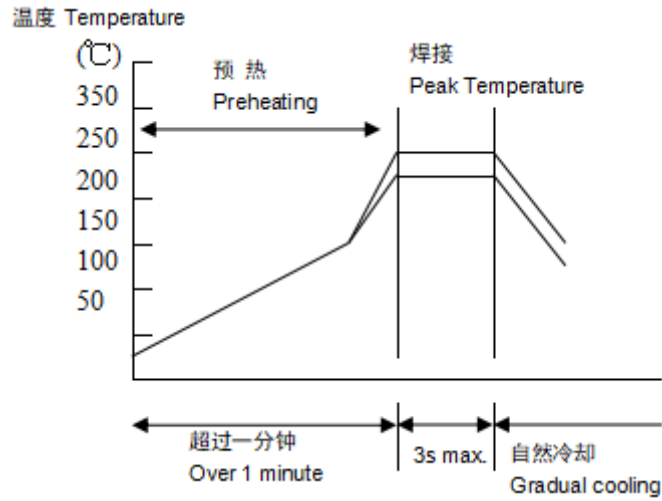

	Pb-Sn 焊接 Pb-Sn soldering	无铅焊接 Lead-free soldering
尖峰温度 Peak temperature	230°C~260°C	240°C~270°C

在预热时, 请将焊接温度与芯片表面温度之间的温差维持在 $T \leq 150^\circ\text{C}$ 。

While in preheating, please keep the temperature difference between soldering temperature and surface temperature of chips as: $T \leq 150^\circ\text{C}$.

* 手工焊接
 Hand soldering

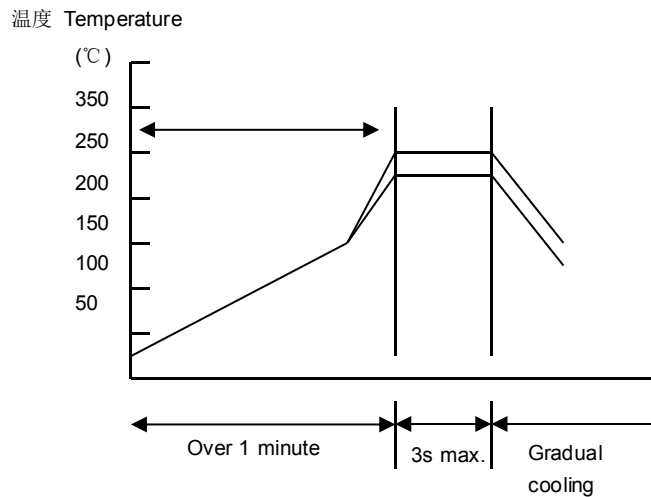

条件 Conditions:

预热 Preheating	烙铁头温度 Temperature of soldering iron head	烙铁功率 Power of soldering iron	烙铁头直径 Diameter of soldering iron head	焊接时间 Soldering time	锡膏量 Solder paste amount	限制条件 Restricted conditions
$\Delta \leq 130^\circ\text{C}$	最高 350°C Highest temperature: 350°C	最大 20W 20W at the highest	建议 1mm 1mm recommended	最长 3s 3s at the longest	$\leq 1/2$ 芯片厚度 $\leq 1/2$ chip thickness	请勿使用烙铁头直接接触陶瓷元件 Please avoid the direct contact between soldering iron head and ceramic components

*以最新版本的内容为准

单击下面可查看定价，库存，交付和生命周期等信息

[>>FH\(风华高科\)](#)