

TLA Series

• 105°C 3,000Hrs assured.

- Non-solvent proof.
- Long Life.
- For SMPS, Inverter.
- RoHS compliant.
- Halogen-free capacitors are also available.



SPECIFICATIONS

Item	Characteristics						
Rated Voltage Range	160 ~ 500 V _{DC}						
Operating Temperature Range	-25 ~ +105°C						
Capacitance Tolerance	±20%(M) (at 20°C, 120Hz)						
Leakage Current	I = 0.02CV or 3mA, whichever is smaller. Where, I: Leakage Current(µA), C: Nominal capacitance(µF), V: Rated voltage(V _{DC}) (at 20°C, 5minutes)						
※ Dissipation Factor(Tanδ)	<table border="1"> <tr> <td>Rated voltage(V_{DC})</td> <td>160 ~ 500</td> </tr> <tr> <td>Tanδ(Max.)</td> <td>0.20</td> </tr> </table> (at 20°C, 120Hz)	Rated voltage(V _{DC})	160 ~ 500	Tanδ(Max.)	0.20		
Rated voltage(V _{DC})	160 ~ 500						
Tanδ(Max.)	0.20						
Temperature Characteristics (Max. Impedance ratio)	<table border="1"> <tr> <td>Rated voltage(V_{DC})</td> <td>160 ~ 400</td> <td>420 ~ 500</td> </tr> <tr> <td>Z(-25°C)/Z(20°C)</td> <td>4</td> <td>8</td> </tr> </table> (at 120Hz)	Rated voltage(V _{DC})	160 ~ 400	420 ~ 500	Z(-25°C)/Z(20°C)	4	8
Rated voltage(V _{DC})	160 ~ 400	420 ~ 500					
Z(-25°C)/Z(20°C)	4	8					
Load Life	The following specifications shall be satisfied when the capacitors are restored to 20°C after the rated voltage is applied for 3,000 hours at 105°C. Capacitance change ≤ ±20% of the initial value Tanδ ≤ 200% of the initial specified value Leakage current ≤ The initial specified value						
Shelf Life	The following specifications shall be satisfied when the capacitors are restored to 20°C after the exposing them at 105°C for 1,000 hours without voltage applied. The rated voltage shall be applied to the capacitors for a minimum of 30 minutes, at least 24 hours and not more than 48 hours before the measurements. Capacitance change ≤ ±20% of the initial value Tanδ ≤ 200% of the initial specified value Leakage current ≤ The initial specified value						
Others	Satisfied characteristics KS C IEC 60384-4						

※ For capacitors with CV products > 100,000 higher Tanδ value may apply.
 When the capacitance exceeds 1,000µF, 0.01 shall be added every 1,000µF increase.

RATED RIPPLE CURRENT

When capacitor are operated in any other condition at 120Hz, the maximum ripple current must be multiplied by the figure shown in the table.

Frequency multiplying factor

V _{DC} \ Freq.(Hz)	60	120	300	1k	10k~
160~250V _{DC}	0.81	1.00	1.17	1.32	1.45
350~500V _{DC}	0.77	1.00	1.16	1.30	1.41

DIMENSIONS OF TLA Series

Unit(mm)

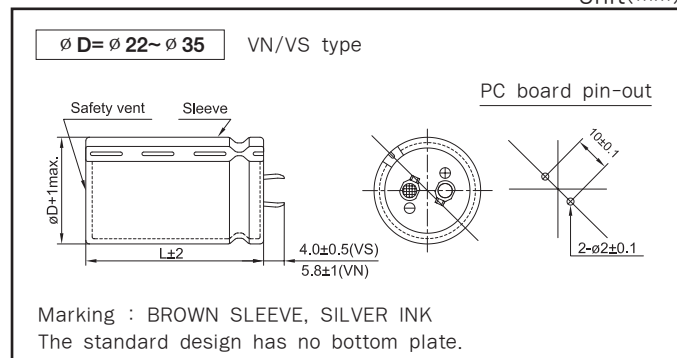

RATINGS OF TLA Series

μF \ Vdc / ØD	160				200				250			
	22	25.4	30	35	22	25.4	30	35	22	25.4	30	35
180									22 × 25 0.78			
220									22 × 30 1.00	25.4 × 25 0.95		
270					22 × 25 1.10				22 × 30 1.18	25.4 × 25 1.18		
330	22 × 25 1.20				22 × 30 1.25	25.4 × 25 1.25			22 × 35 1.30	25.4 × 35 1.30	30 × 25 1.30	
390	22 × 25 1.26	25.4 × 25 1.30			22 × 30 1.35	25.4 × 25 1.35			22 × 40 1.49	25.4 × 35 1.49	30 × 25 1.49	
470	22 × 30 1.33	25.4 × 25 1.33			22 × 40 1.50	25.4 × 30 1.50	30 × 25 1.50		22 × 45 1.65	25.4 × 35 1.65	30 × 30 1.65	35 × 25 1.65
560	22 × 35 1.60	25.4 × 30 1.60	30 × 25 1.60		22 × 45 1.67	25.4 × 30 1.60	30 × 25 1.60		22 × 50 1.67	25.4 × 40 1.80	30 × 30 1.80	35 × 25 1.80
680	22 × 40 1.82	25.4 × 30 1.82	30 × 25 1.82		22 × 45 1.78	25.4 × 35 1.78	30 × 30 1.78	35 × 25 1.78		25.4 × 50 2.00	30 × 35 2.00	35 × 30 2.00
820	22 × 45 2.04	25.4 × 35 2.04	30 × 30 2.04	35 × 25 2.04		25.4 × 45 2.04	30 × 30 2.04	35 × 25 2.04		25.4 × 60 2.20	30 × 40 2.30	35 × 35 2.30
1,000	22 × 50 2.25	25.4 × 40 2.25	30 × 30 2.25	35 × 25 2.25		25.4 × 50 2.30	30 × 35 2.30	35 × 30 2.30			30 × 50 2.47	35 × 40 2.47
1,200		25.4 × 45 2.49	30 × 35 2.49	35 × 30 2.49		25.4 × 60 2.66	30 × 40 2.65	35 × 35 2.65			30 × 60 2.85	35 × 45 2.60
1,500		25.4 × 60 2.97	30 × 40 2.84	35 × 30 2.84			30 × 50 3.08	35 × 40 3.08				35 × 50 3.00
1,800			30 × 45 3.32	35 × 35 3.00			30 × 60 3.49	35 × 45 3.48				35 × 60 3.42
2,200			30 × 60 3.86	35 × 45 3.50				35 × 50 3.78	← Case Size ØD×L(mm) ← Rated Ripple Current(Arms/105°C, 120Hz)			

μF \ Vdc / ØD	350				400			
	22	25.4	30	35	22	25.4	30	35
68					22 × 25 0.55			
82	22 × 25 0.55				22 × 25 0.64			
100	22 × 25 0.69				22 × 30 0.70	25.4 × 25 0.70		
120	22 × 30 0.75	25.4 × 25 0.75			22 × 35 0.75	25.4 × 25 0.75	30 × 25 0.80	
150	22 × 35 0.82	25.4 × 30 0.83	30 × 25 0.82		22 × 40 0.88	25.4 × 30 0.88	30 × 25 0.88	
180	22 × 40 0.92	25.4 × 30 0.92	30 × 25 0.90		22 × 45 0.98	25.4 × 35 0.98	30 × 30 0.98	35 × 25 0.98
220	22 × 45 1.05	25.4 × 35 1.04	30 × 30 1.02	35 × 25 1.04	22 × 50 1.10	25.4 × 40 1.10	30 × 30 1.10	35 × 25 1.0
270	22 × 50 1.16	25.4 × 40 1.18	30 × 30 1.17	35 × 25 1.20		25.4 × 45 1.22	30 × 35 1.22	35 × 30 1.22
330		25.4 × 45 1.29	30 × 35 1.34	35 × 30 1.22		25.4 × 50 1.44	30 × 40 1.44	35 × 30 1.44
390		25.4 × 50 1.51	30 × 40 1.51	35 × 35 1.47		25.4 × 60 1.51	30 × 45 1.60	35 × 35 1.60
470		25.4 × 60 1.66	30 × 45 1.65	35 × 35 1.69			30 × 50 1.90	35 × 40 1.90
560			30 × 50 1.85	35 × 40 1.90			30 × 60 2.10	35 × 45 2.12
680			30 × 60 2.15	35 × 50 1.99				35 × 60 2.27

RATINGS OF TLA Series

V _{dc} μF ∅D	420				450			
	22	25.4	30	35	22	25.4	30	35
56					22 × 25 0.40			
68	22 × 25 0.50				22 × 30 0.53	25.4 × 25 0.50		
82	22 × 25 0.64	25.4 × 25 0.58			22 × 30 0.64	25.4 × 25 0.64		
100	22 × 30 0.70	25.4 × 25 0.70			22 × 35 0.69	25.4 × 30 0.69	30 × 25 0.64	
120	22 × 35 0.75	25.4 × 30 0.75	30 × 25 0.73		22 × 40 0.80	25.4 × 30 0.80	30 × 25 0.80	35 × 25 0.73
150	22 × 40 0.88	25.4 × 35 0.88	30 × 25 0.88		22 × 45 0.88	25.4 × 35 0.88	30 × 30 0.88	35 × 25 0.75
180	22 × 45 0.95	25.4 × 35 0.95	30 × 30 0.95	35 × 25 0.94	22 × 50 1.00	25.4 × 40 1.00	30 × 30 1.00	
220	22 × 50 1.10	25.4 × 45 1.10	30 × 35 1.10	35 × 25 1.10		25.4 × 45 1.12	30 × 35 1.12	35 × 30 1.12
270		25.4 × 50 1.22	30 × 40 1.22	35 × 30 1.22		25.4 × 50 1.18	30 × 40 1.28	35 × 35 1.28
330		25.4 × 60 1.41	30 × 45 1.45	35 × 35 1.45			30 × 50 1.45	35 × 40 1.45
390			30 × 50 1.55	35 × 40 1.55			30 × 60 1.51	35 × 40 1.55
470			30 × 60 1.79	35 × 45 1.90	← Case Size ∅D × L (mm) ← Rated Ripple Current (Arms/105°C, 120Hz)			

V _{dc} μF ∅D	500			
	22	25.4	30	35
56	22 × 35 0.46	25.4 × 30 0.46	30 × 30 0.48	
68	22 × 40 0.50	25.4 × 35 0.53	30 × 30 0.55	
82	22 × 45 0.56	25.4 × 35 0.58	30 × 35 0.58	
100		25.4 × 40 0.65	30 × 35 0.66	
120		25.4 × 45 0.75	30 × 40 0.76	35 × 30 0.78
150			30 × 45 0.80	35 × 35 0.81
180			30 × 50 0.90	35 × 40 0.93
220			30 × 60 1.10	35 × 45 1.11
270				35 × 50 1.28
330				35 × 60 1.50

单击下面可查看定价，库存，交付和生命周期等信息

[>>SAMYOUNG\(三荣\)](#)