

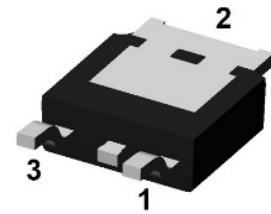
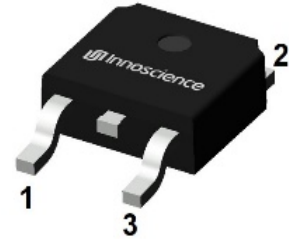
# INN700TK240B

## 1. General description

700V GaN-on-Silicon Enhancement-mode Power Transistor in TO-252 package.

## 2. Features

- Enhancement mode transistor-Normally off power switch
- Ultra high switching frequency
- No reverse-recovery charge
- Low gate charge, low output charge
- Qualified for industrial applications according to JEDEC Standards
- ESD safeguard
- RoHS, Pb-free, REACH-compliant



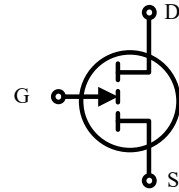
## 3. Applications

- AC-DC converters
- DC-DC converters
- Totem pole PFC
- Fast battery charging
- High density power conversion
- High efficiency power conversion

## 4. Key performance parameters

**Table 1** Key performance parameters at  $T_j = 25\text{ }^\circ\text{C}$

| Parameter                                | Value | Unit       |
|--|-------|------------|
| $V_{DS,max}$                             | 700   | V          |
| $R_{DS(on),max}$ @ $V_{GS} = 6\text{ V}$ | 240   | m $\Omega$ |
| $Q_{G,typ}$ @ $V_{DS} = 400\text{ V}$    | 2     | nC         |
| $I_{D,pulse}$                            | 18    | A          |
| $Q_{OSS}$ @ $V_{DS} = 400\text{ V}$      | 21    | nC         |
| $Q_{rr}$ @ $V_{DS} = 400\text{ V}$       | 0     | nC         |



## 5. Pin information

**Table 2** Pin information

| Gate | Source | Drain |
|------|--------|-------|
| 1    | 2      | 3     |

**Table 3** Ordering information

| Type/Ordering Code | Package | Product Code |
|--------------------|---------|--------------|
| INN700TK240B       | TO-252  | 70TK240B     |

**Table of contents**

**1. General description ..... 1**

**2. Features ..... 1**

**3. Applications..... 1**

**4. Key performance parameters..... 1**

**5. Pin information ..... 1**

**6. Maximum ratings ..... 3**

**7. Thermal characteristics ..... 4**

**8. Electric characteristics ..... 5**

**9. Electric characteristics diagrams ..... 7**

**10.Package outlines ..... 13**

**11.Recommended PCB footprint ..... 14**

**12.Revision history ..... 15**

## 6. Maximum ratings

at  $T_j = 25\text{ °C}$  unless otherwise specified.

Exceeding the maximum ratings may destroy the device. For further information, contact Innoscence sales office.

**Table 4** Maximum ratings

| Parameter                                    | Symbol                     | Values      | Unit | Note/Test Condition  |
|--|----------------------------|-------------|------|--|
| Drain source voltage                         | $V_{DS, \max}$             | 700         | V    | $V_{GS} = 0\text{ V}$ ;<br>$T_j = -55\text{ °C}$ to $150\text{ °C}$  |
| Drain source voltage transient <sup>1</sup>  | $V_{DS, \text{transient}}$ | 800         | V    | $V_{GS} = 0\text{ V}$  |
| Drain source voltage, pulsed <sup>2</sup>    | $V_{DS, \text{pulse}}$     | 750         | V    | $T_j = 25\text{ °C}$ ; total time < 10 h   |
|  |                            |             |      | $T_j = 125\text{ °C}$ ; total time < 1 h   |
| Continuous current, drain source             | $I_D$                      | 10          | A    | $T_c = 25\text{ °C}$   |
| Pulsed current, drain source <sup>3</sup>    | $I_{D, \text{pulse}}$      | 18          | A    | $T_c = 25\text{ °C}$ ; $V_{GS} = 6\text{ V}$ ;<br>$t_{\text{PULSE}} = 10\text{ }\mu\text{s}$                           |
| Pulsed current, drain source <sup>3</sup>    | $I_{D, \text{pulse}}$      | 10          | A    | $T_c = 125\text{ °C}$ ; $V_{GS} = 6\text{ V}$ ;<br>$t_{\text{PULSE}} = 10\text{ }\mu\text{s}$                          |
| Gate source voltage, continuous <sup>4</sup> | $V_{GS}$                   | -1.4 to +7  | V    | $T_j = -55\text{ °C}$ to $150\text{ °C}$   |
| Gate source voltage, pulsed                  | $V_{GS, \text{pulse}}$     | -20 to +10  | V    | $T_j = -55\text{ °C}$ to $150\text{ °C}$ ;<br>$t_{\text{PULSE}} = 50\text{ ns}$ , $f = 100\text{ kHz}$ ;<br>open drain |
| Power dissipation                            | $P_{\text{tot}}$           | 73          | W    | $T_c = 25\text{ °C}$   |
| Operating temperature                        | $T_j$                      | -55 to +150 | °C   |  |
| Storage temperature                          | $T_{\text{stg}}$           | -55 to +150 | °C   |  |

1.  $V_{DS, \text{transient}}$  is intended for non-repetitive events,  $t_{\text{PULSE}} < 200\text{ }\mu\text{s}$ .

2.  $V_{DS, \text{pulse}}$  is intended for repetitive pulse,  $t_{\text{PULSE}} < 100\text{ ns}$ .

3. Limit was extracted from characterization test, not measured during production.

4. The minimum  $V_{GS}$  is clamped by ESD protection circuit, as shown in Figure 10.

## 7. Thermal characteristics

**Table 5** Thermal characteristics

| Parameter                            | Symbol                  | Values | Unit | Note/Test Condition |
|--------------------------------------|-------------------------|--------|------|---------------------|
| Thermal resistance, junction-ambient | $R_{thJA}$ <sup>1</sup> | 54     | °C/W |                     |
| Thermal resistance, junction-case    | $R_{thJC}$              | 1.69   | °C/W |                     |
| Maximum reflow soldering temperature | $T_{sold}$              | 260    | °C   | MSL3                |

1. $R_{thJA}$  is determined with the device mounted on one square inch of copper pad, single layer 2oz copper on FR4 board.

## 8. Electric characteristics

at  $T_j = 25\text{ °C}$ , unless specified otherwise

**Table 6 Static characteristics**

| Parameter                        | Symbol       | Values |      |      | Unit          | Note/Test Condition   |
|----------------------------------|--------------|--------|------|------|---------------|---|
|                                  |              | Min.   | Typ. | Max. |               |   |
| Gate threshold voltage           | $V_{GS(th)}$ | 1.2    | 1.7  | 2.5  | V             | $I_D = 11\text{ mA}; V_{DS} = V_{GS}; T_j = 25\text{ °C}$         |
|                                  |              | -      | 1.7  | -    |               | $I_D = 11\text{ mA}; V_{DS} = V_{GS}; T_j = 150\text{ °C}$        |
| Drain-source leakage current     | $I_{DSS}$    | -      | 0.4  | 20   | $\mu\text{A}$ | $V_{DS} = 700\text{ V}; V_{GS} = 0\text{ V}; T_j = 25\text{ °C}$  |
|                                  |              | -      | 5    | -    |               | $V_{DS} = 700\text{ V}; V_{GS} = 0\text{ V}; T_j = 150\text{ °C}$ |
| Gate-source leakage current      | $I_{GSS}$    | -      | 50   | -    | $\mu\text{A}$ | $V_{GS} = 6\text{ V}; V_{DS} = 0\text{ V}$                        |
| Drain-source on-state resistance | $R_{DS(on)}$ | -      | 165  | 240  | m $\Omega$    | $V_{GS} = 6\text{ V}; I_D = 3\text{ A}; T_j = 25\text{ °C}$       |
|                                  |              | -      | 360  | -    |               | $V_{GS} = 6\text{ V}; I_D = 3\text{ A}; T_j = 150\text{ °C}$      |
| Gate resistance                  | $R_G$        | -      | 6    | -    | $\Omega$      | $f = 5\text{ MHz}; \text{open drain}$                             |

**Table 7 Dynamic characteristics**

| Parameter   | Symbol       | Values |      |      | Unit | Note/Test Condition   |
|---|--------------|--------|------|------|------|---|
|   |              | Min.   | Typ. | Max. |      |   |
| Input capacitance   | $C_{iss}$    | -      | 79   | -    | pF   | $V_{GS} = 0\text{ V}; V_{DS} = 400\text{ V}; f = 100\text{ kHz}$  |
| Output capacitance  | $C_{oss}$    | -      | 25   | -    | pF   | $V_{GS} = 0\text{ V}; V_{DS} = 400\text{ V}; f = 100\text{ kHz}$  |
| Reverse transfer capacitance                              | $C_{rss}$    | -      | 0.2  | -    | pF   | $V_{GS} = 0\text{ V}; V_{DS} = 400\text{ V}; f = 100\text{ kHz}$  |
| Effective output capacitance, energy related <sup>1</sup> | $C_{o(er)}$  | -      | 36   | -    | pF   | $V_{GS} = 0\text{ V}; V_{DS} = 0\text{ to }400\text{ V}$  |
| Effective output capacitance, time related <sup>2</sup>   | $C_{o(tr)}$  | -      | 52   | -    | pF   | $V_{GS} = 0\text{ V}; V_{DS} = 0\text{ to }400\text{ V}$  |
| Output charge   | $Q_{oss}$    | -      | 21   | -    | nC   | $V_{GS} = 0\text{ V}; V_{DS} = 0\text{ to }400\text{ V}$  |
| Turn-on delay time  | $t_{d(on)}$  | -      | 2    | -    | ns   | $V_{DS} = 400\text{ V}; I_D = 6\text{ A}; L = 318\text{ }\mu\text{H};$<br>$V_{GS} = 6\text{ V}; R_{on} = 10\text{ }\Omega; R_{off} = 2\text{ }\Omega;$<br>See Figure 22 |
| Turn-off delay time                                       | $t_{d(off)}$ | -      | 4    | -    | ns   |   |
| Rise time   | $t_r$        | -      | 5    | -    | ns   |   |
| Fall time   | $t_f$        | -      | 6    | -    | ns   |   |

1.  $C_{o(er)}$  is the fixed capacitance that gives the same stored energy as  $C_{oss}$  while  $V_{DS}$  is rising from 0 to 400 V.

2.  $C_{o(tr)}$  is the fixed capacitance that gives the same charging time as  $C_{oss}$  while  $V_{DS}$  is rising from 0 to 400 V.

**Table 8 Gate charge characteristics**

| Parameter            | Symbol     | Values |      |      | Unit | Note/Test Condition                                   |
|----------------------|------------|--------|------|------|------|---|
|                      |            | Min.   | Typ. | Max. |      |   |
| Gate charge          | $Q_G$      | -      | 2    | -    | nC   | $V_{GS} = 0$ to 6 V; $V_{DS} = 400$ V;<br>$I_D = 3$ A |
| Gate-source charge   | $Q_{GS}$   | -      | 0.2  | -    | nC   |   |
| Gate-drain charge    | $Q_{GD}$   | -      | 0.7  | -    | nC   |   |
| Gate Plateau Voltage | $V_{Plat}$ | -      | 2.5  | -    | V    | $V_{DS} = 400$ V; $I_D = 3$ A                         |

**Table 9 Reverse conduction characteristics**

| Parameter                     | Symbol         | Values |      |      | Unit | Note/Test Condition                      |
|-------------------------------|----------------|--------|------|------|------|--|
|                               |                | Min.   | Typ. | Max. |      |  |
| Source-Drain reverse voltage  | $V_{SD}$       | -      | 2.6  | -    | V    | $V_{GS} = 0$ V; $I_S = 3$ A              |
| Pulsed current, reverse       | $I_{S, pulse}$ | -      | -    | 18   | A    | $V_{GS} = 6$ V; $t_{PULSE} = 10$ $\mu$ s |
| Reverse recovery charge       | $Q_{rr}$       | -      | 0    | -    | nC   | $I_S = 3$ A; $V_{DS} = 400$ V            |
| Reverse recovery time         | $t_{rr}$       | -      | 0    | -    | ns   |  |
| Peak reverse recovery current | $I_{rrm}$      | -      | 0    | -    | A    |  |

## 9. Electric characteristics diagrams

at  $T_j = 25\text{ }^\circ\text{C}$ , unless specified otherwise

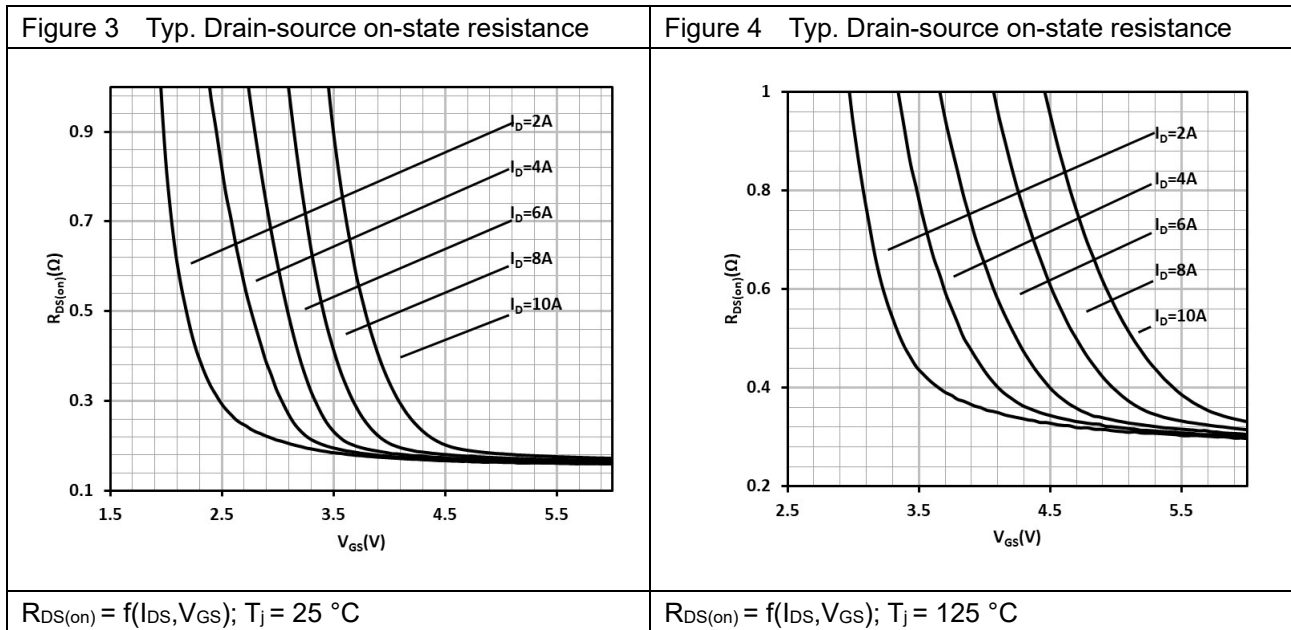
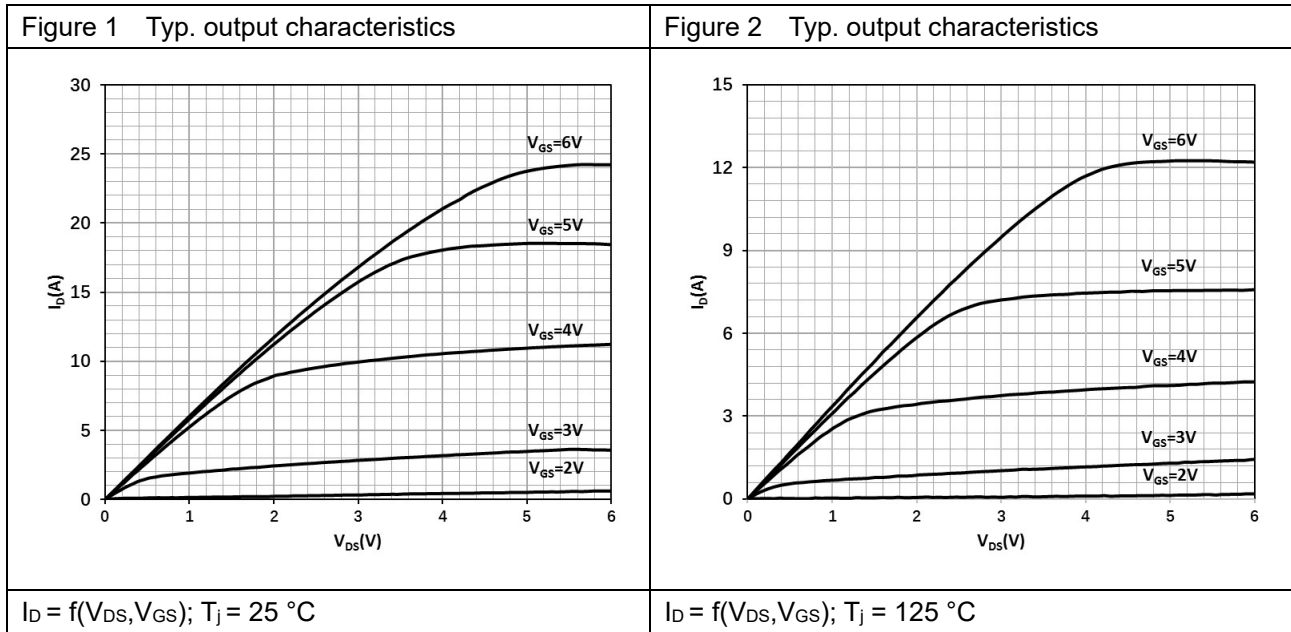
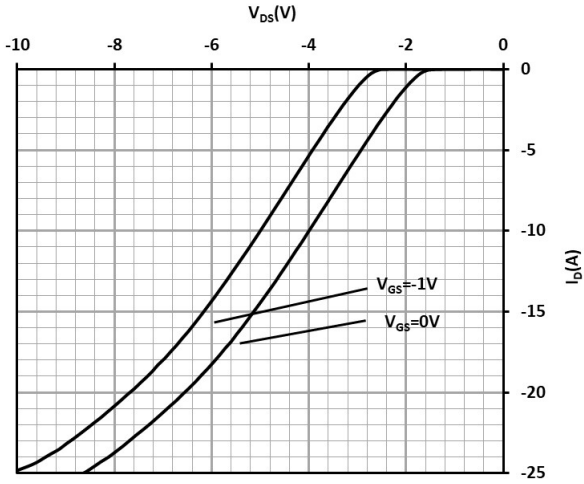
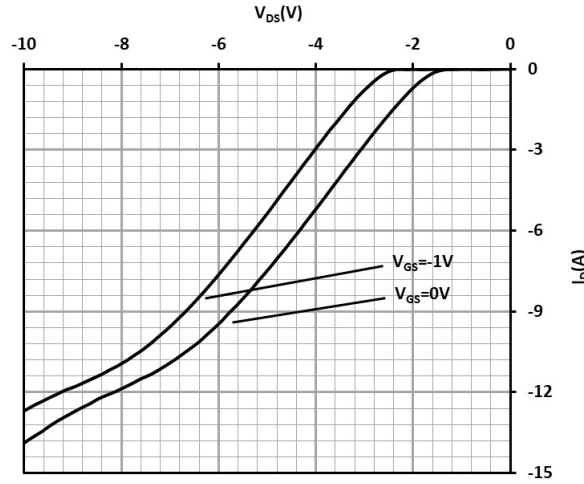


Figure 5 Typ. channel reverse characteristics



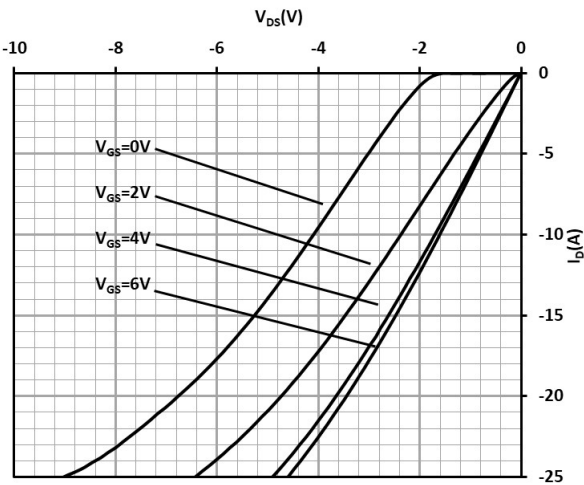
$I_D = f(V_{DS}, V_{GS}); T_j = 25\text{ }^\circ\text{C}$

Figure 6 Typ. channel reverse characteristics



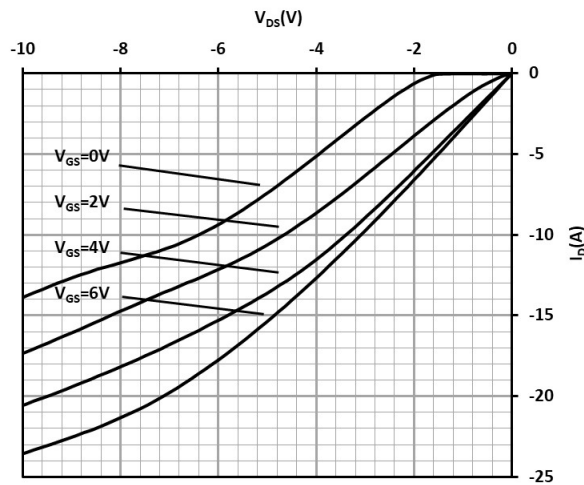
$I_D = f(V_{DS}, V_{GS}); T_j = 125\text{ }^\circ\text{C}$

Figure 7 Typ. channel reverse characteristics



$I_D = f(V_{DS}, V_{GS}); T_j = 25\text{ }^\circ\text{C}$

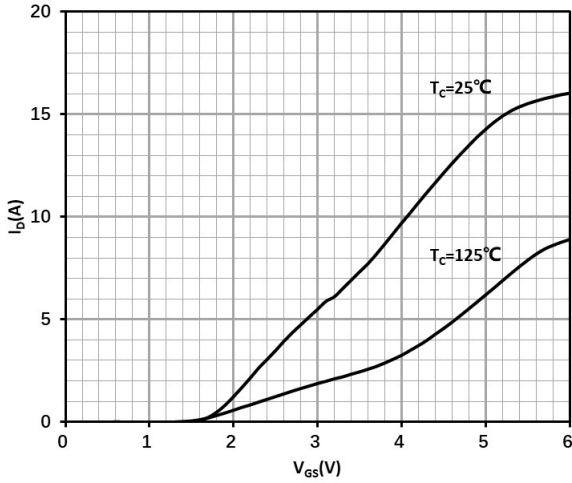
Figure 8 Typ. channel reverse characteristics



$I_D = f(V_{DS}, V_{GS}); T_j = 125\text{ }^\circ\text{C}$

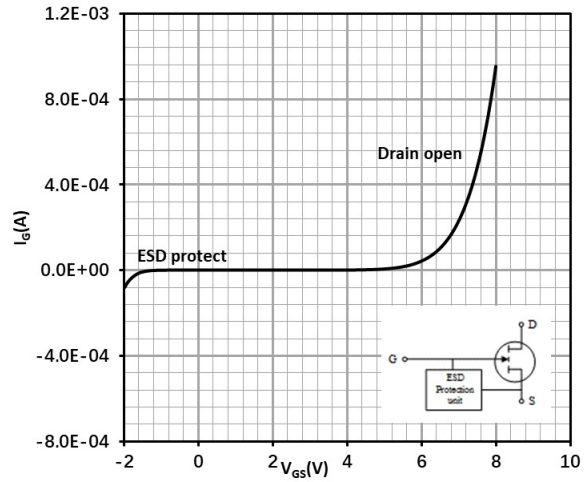


Figure 9 Typ. transfer characteristics



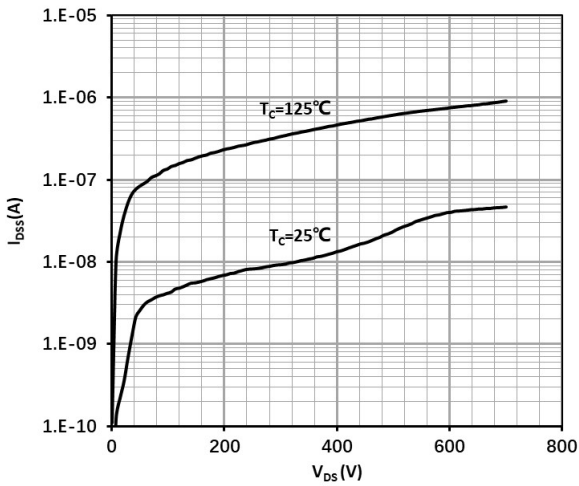
$I_D = f(V_{GS}); V_{DS} = 3\text{ V}$

Figure 10 Typ. Gate-to-Source leakage



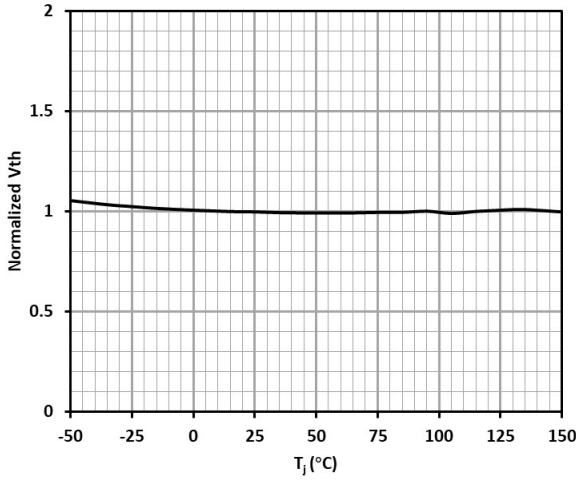
$I_G = f(V_{GS}); I_G$  reverse turn on by ESD unit

Figure 11 Drain-source leakage characteristics



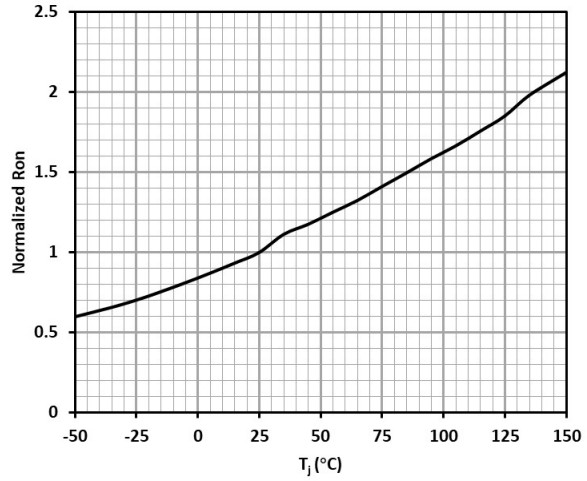
$I_{DSS} = f(V_{DS}); V_{GS} = 0\text{ V}$

Figure 12 Gate threshold voltage



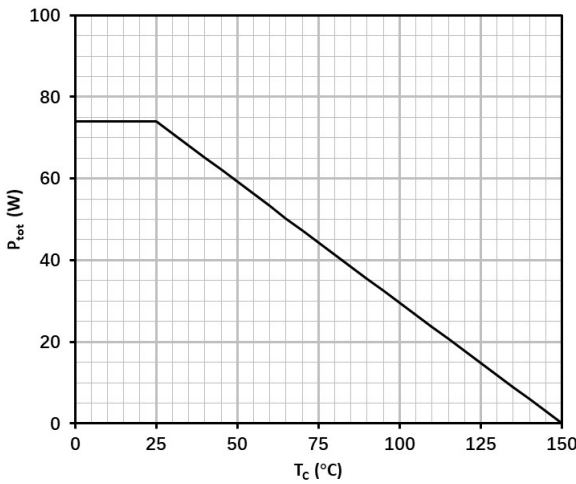
$V_{TH} = f(T_j); V_{GS} = V_{DS}; I_D = 11 \text{ mA}$

Figure 13 Drain-source on-state resistance



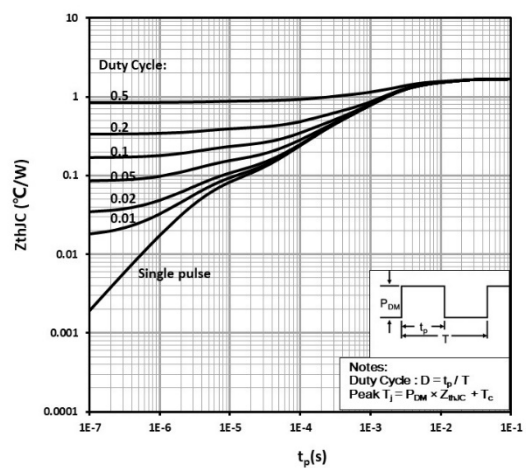
$R_{DS(on)} = f(T_j); I_D = 3 \text{ A}; V_{GS} = 6 \text{ V}$

Figure 14 Power dissipation



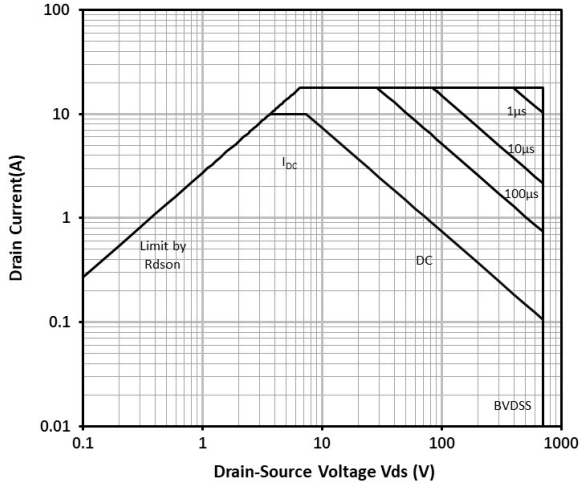
$P_{tot} = f(T_c)$

Figure 15 Max. transient thermal impedance



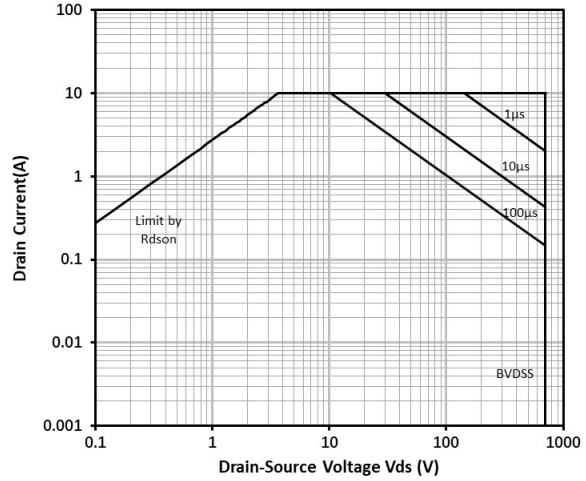
$Z_{thJC} = f(t_p, D)$

Figure 16 Safe operating area



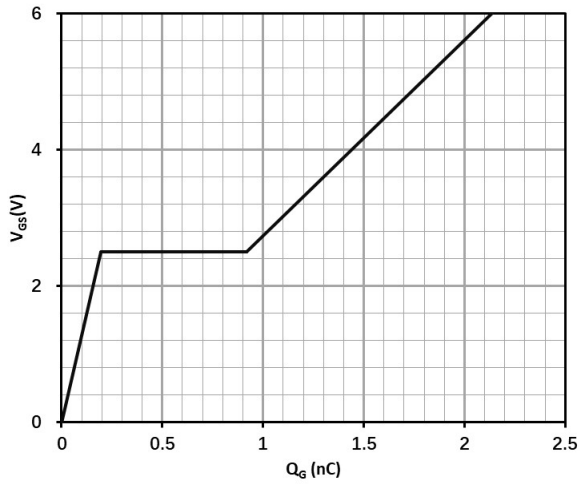
$I_D = f(V_{DS}); T_C = 25\text{ °C}$

Figure 17 Safe operating area



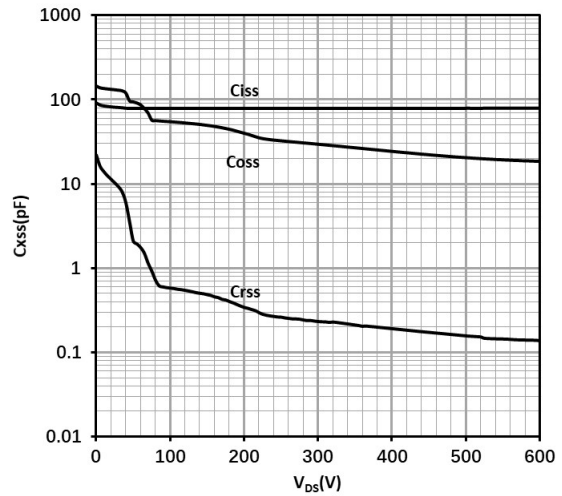
$I_D = f(V_{DS}); T_C = 125\text{ °C}$

Figure 18 Typ. gate charge



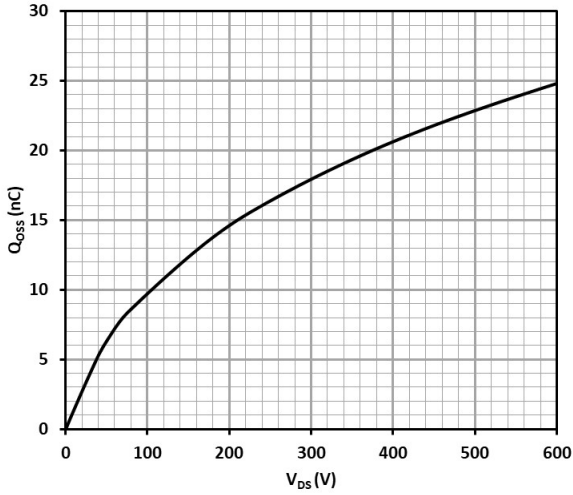
$V_{GS} = f(Q_G); V_{DCLINK} = 400\text{ V}; I_D = 3\text{ A}$

Figure 19 Typ. capacitances



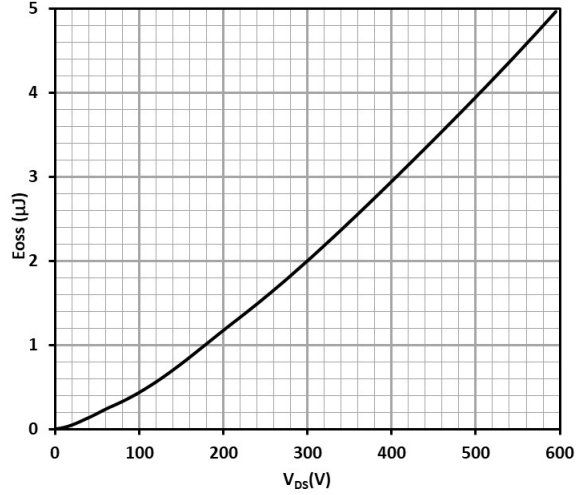
$C_{XSS} = f(V_{DS}); \text{Freq.} = 100\text{ kHz}$

Figure 20 Typ. output charge



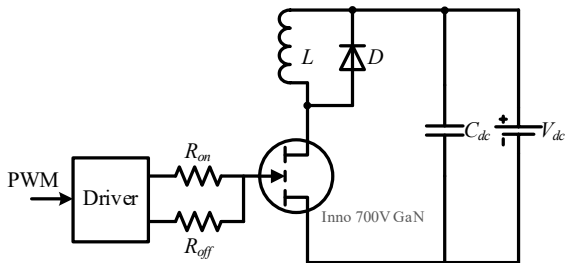
$Q_{oss} = f(V_{DS}); \text{Freq.} = 100 \text{ kHz}$

Figure 21 Typ. Coss stored Energy



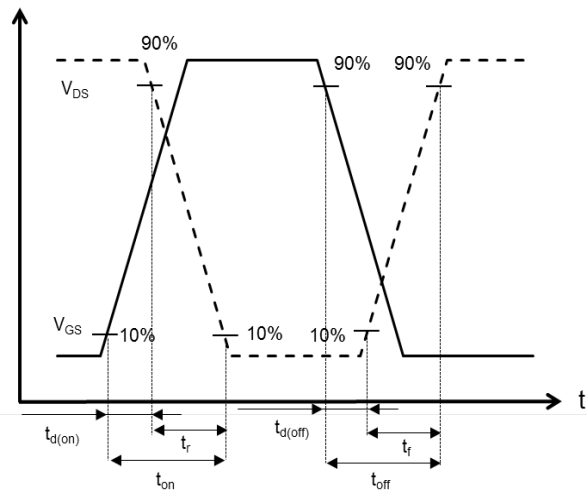
$E_{oss} = f(V_{DS}); \text{Freq.} = 100 \text{ kHz}$

Figure 22 Typ. Switching times with inductive load

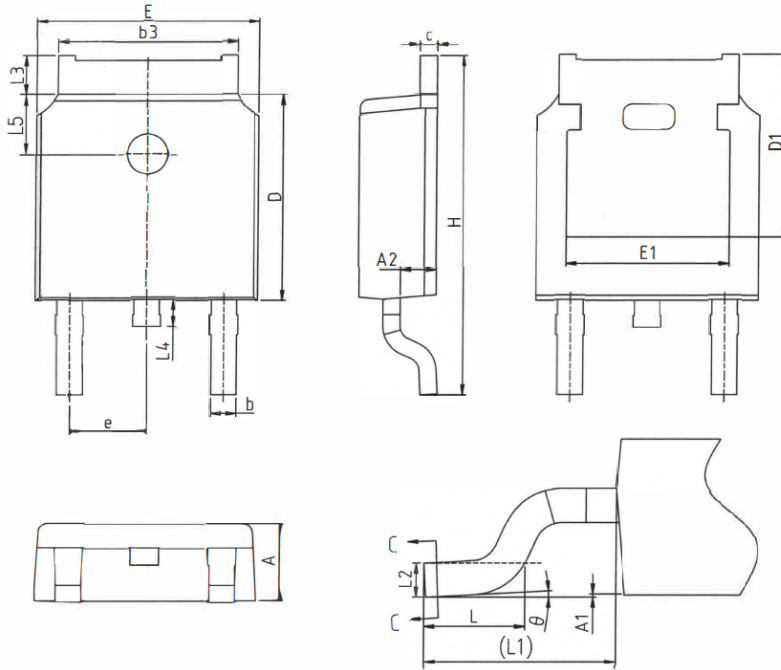


$V_{DS} = 400 \text{ V}, I_D = 6 \text{ A}, L = 318 \mu\text{H}, V_{GS} = 6 \text{ V},$   
 $R_{on} = 10 \Omega, R_{off} = 2 \Omega$

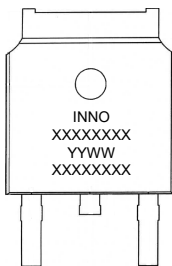
Figure 23 Typ. Switching times waveform



## 10. Package outlines



| SYMBOL | MM      |      |      | SYMBOL   | MM       |       |       |
|--------|---------|------|------|----------|----------|-------|-------|
|        | MIN     | NOM  | MAX  |          | MIN      | NOM   | MAX   |
| A      | 2.20    | 2.30 | 2.40 | e        | 2.286BSC |       |       |
| A1     | 0.00    | -    | 0.13 | H        | 9.40     | 10.10 | 10.50 |
| A2     | 0.92    | 1.07 | 1.17 | L        | 1.38     | 1.50  | 1.75  |
| b      | 0.63    | 0.78 | 0.90 | L1       | 2.90REF  |       |       |
| b3     | 5.10    | 5.33 | 5.46 | L2       | 0.51BSC  |       |       |
| c      | 0.43    | 0.53 | 0.61 | L3       | 0.88     | -     | 1.28  |
| D      | 5.98    | 6.1  | 6.22 | L4       | 0.50     | -     | 1.00  |
| D1     | 5.30REF |      |      | L5       | 1.65     | 1.80  | 1.95  |
| E      | 6.40    | 6.60 | 6.73 | $\theta$ | 0°       | -     | 8°    |
| E1     | 4.83REF |      |      |          |          |       |       |

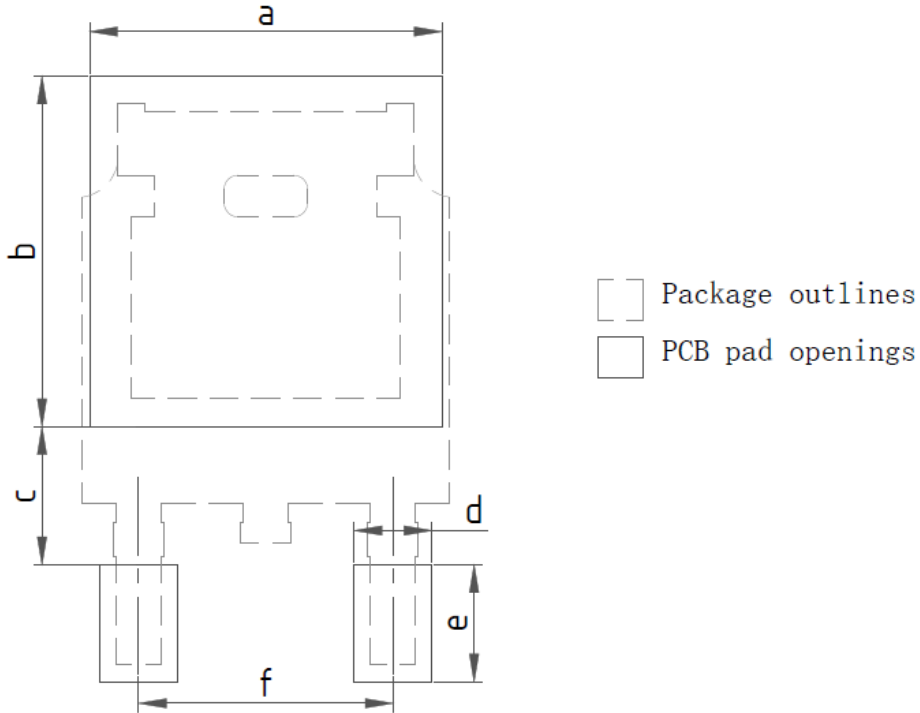


| ROW  | Description  | Example  |
|------|--------------|----------|
| Row1 | Company name | INNO     |
| Row2 | Product code | XXXXXXXX |
| Row3 | Date code    | YYWW     |
| Row4 | ASSY lot No. | XXXXXXXX |

**Notes:**

- (1) All dimension are in millimeters.
- (2) Drawing is not to scale.
- (3) Dimensions do not include mold protrusion.
- (4) Package outline exclusive of metal burr dimensions.

**11. Recommended PCB footprint**



| SYMBOL | DIMENSION | SYMBOL | DIMENSION |
|--------|-----------|--------|-----------|
| a      | 6.33      | d      | 1.40      |
| b      | 6.30      | e      | 2.10      |
| c      | 2.48      | f      | 4.57      |

Notes:  
 (1) All dimensions are in millimeters.  
 (2) Drawing is not to scale.

## 12. Revision history

### Major changes since the last revision

| Revision | Date       | Description of changes |
|----------|------------|------------------------|
| 1.0      | 2023-04-21 | 1.0 version release    |

---

## Important Notice

The information provided in this document is intended as a guide only and shall not in any event be regarded as a guarantee of conditions, characteristics or performance. Innoscience does not assume any liability arising out of the application or use of any product described herein, including but not limited to any personal injury, death, or property or environmental damage. No licenses, patent rights, or any other intellectual property rights is granted or conveyed. Innoscience reserves the right to modify without notice. All rights reserved.



单击下面可查看定价，库存，交付和生命周期等信息

[>>Innoscience](#)