

■ 绕线型片式铁氧体电感

Wire Wound Chip Ferrite Inductors

◆ 特征 Feature

- * 体积小, 适合高密度表面贴装
Minature Size, Suitable For SMT.
- * 采用端电极结构, 很好地抑制了引线引起的寄生元件效应, 具有高可靠性
Using Terminal Electrode Structure To Restrain The Parasitic Component Effect Quite Caused By Lead.
- * 精度高、Q 值高
Low DC Resistance , High Current And High inductance.
- * 优良的焊接性和耐焊性
Excellent In Solderability And Heat Resistance.



◆ 应用 Application

- * 视听设备、无线通讯设备和各类通用电子设备
Wireless Communication Equipment And Various Types Of General Electronic Equipment.
- * 蓝牙模块, 音频电路
Bluetooth, Audio Circuit.
- * 其它电子设备
Other Electronic Equipment.

◆ 型号表示法 Part Number

FHW	0805	UF	R68	J	S	T
①	②	③	④	⑤	⑥	⑦

① 产品类型 Product Typel:

FHW: 绕线型片式电感器系列

FHW: Wire Wound Inductor Series

② 尺寸 Dimensions: 0603(1.6×0.8mm)、0805(2.0×1.2mm)、1008 (2.5×2.0mm)、1210 (3.2×2.5mm)、1812(4.5×3.2mm)

③ 材料代号 Material Code: UF/IF---铁氧体芯 Ferrite core

④ 标称电感量 Inductance: 010=10nH、R10=100nH、1R0=1.0μH、100=10μH、101=100μH、102=1mH

⑤ 标称电感值偏差 Tolerance: J---±5%; K---±10%; M---±20%

⑥ 电极表面镀层材料 Terminal: S---锡端头 Tin

⑦ 包装 Packaging: T: 编带包装 Tape & Reel B: 散装 Bulk

◆ 产品结构 Product Structure

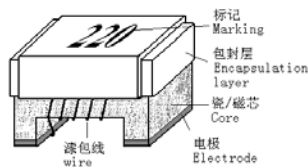

◆规格尺寸 Dimension

单位 Unit: mm (inch)

Size	L (Max)	W (Max)	T (Max)	A	B
1608 (0603)	1.78 (0.070)	1.10 (0.043)	0.95 (0.037)	0.76 (0.030)	0.30 (0.012)
2012 (0805)	2.30 (0.091)	1.70 (0.067)	1.52 (0.060)	1.27 (0.050)	0.50 (0.020)
2520 (1008)	2.92 (0.115)	2.79 (0.110)	2.10 (0.083)	2.00 (0.079)	0.50 (0.020)
3225 (1210)	3.50 (0.138)	2.90 (0.114)	2.25 (0.088)	2.10 (0.083)	0.50 (0.020)
4532 (1812)	4.80 (0.189)	3.40 (0.134)	3.15 (0.124)	2.53 (0.100)	0.65 (0.026)

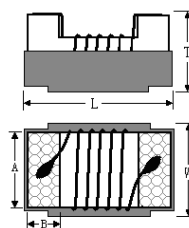
◆电性能参数 ELECTRICAL CHARACTERISTICS

0603 Type

型号 Part NO	电感量 Inductance (μ H)	偏差范围 Tolerance	Q 值 Q (Min)	自谐振频率 SRF (MHZ) Min	最大直流电阻 Rdc (Ω) Max	额定电流 Idc(A) Max
FHW0603UF047 \square ST	0.047@7.9MHz	10,5	12@7.9MHz	1500	0.100	1000
FHW0603UF072 \square ST	0.072@7.9MHz	10,5	12@7.9MHz	1400	0.120	1000
FHW0603UFR82 \square ST	0.082@7.9MHz	10,5	12@7.9MHz	1300	0.100	1000
FHW0603UFR10 \square ST	0.10@7.9MHz	10,5	12@7.9MHz	1150	0.130	1000
FHW0603UFR12 \square ST	0.12@7.9MHz	10,5	12@7.9MHz	1100	0.160	1000
FHW0603UFR15 \square ST	0.15@7.9MHz	10,5	12@7.9MHz	1050	0.150	1000
FHW0603UFR18 \square ST	0.18@7.9MHz	10,5	12@7.9MHz	950	0.150	1000
FHW0603UFR22 \square ST	0.22@7.9MHz	10,5	12@7.9MHz	900	0.160	900
FHW0603UFR27 \square ST	0.27@7.9MHz	10,5	12@7.9MHz	775	0.300	700
FHW0603UFR33 \square ST	0.33@7.9MHz	10,5	12@7.9MHz	725	0.320	600
FHW0603UFR39 \square ST	0.39@7.9MHz	10,5	12@7.9MHz	620	0.510	500
FHW0603UFR47 \square ST	0.47@7.9MHz	10,5	12@7.9MHz	540	0.620	420
FHW0603UFR56 \square ST	0.56@7.9MHz	10,5	12@7.9MHz	600	0.650	400
FHW0603UFR68 \square ST	0.68@7.9MHz	10,5	12@7.9MHz	500	1.000	380
FHW0603UFR82 \square ST	0.82@7.9MHz	10,5	12@7.9MHz	500	1.300	350
FHW0603UF1R0 \square ST	1.0@7.9MHz	10,5	12@7.9MHz	400	1.500	330
FHW0603UF1R2 \square ST	1.2@7.9MHz	10,5	12@7.9MHz	380	1.700	320
FHW0603UF1R5 \square ST	1.5@7.9MHz	10,5	12@7.9MHz	300	1.900	310
FHW0603UF1R8 \square ST	1.8@7.9MHz	10,5	12@7.9MHz	180	2.200	300
FHW0603UF2R2 \square ST	2.2@7.9MHz	10,5	12@7.9MHz	180	2.300	280
FHW0603UF2R7 \square ST	2.7@7.9MHz	10,5	12@7.9MHz	150	3.100	250
FHW0603UF3R3 \square ST	3.3@7.9MHz	10,5	12@7.9MHz	150	2.900	230
FHW0603UF3R9 \square ST	3.9@7.9MHz	10,5	12@7.9MHz	120	3.200	210
FHW0603UF4R7 \square ST	4.7@7.9MHz	10,5	12@7.9MHz	100	4.000	200

0805 Type

型号 Part NO	电感量 Inductance (μ H)	偏差范围 Tolerance	Q 值 Q (Min)	自谐振频率 SRF (MHZ) Min	最大直流电阻 Rdc (Ω) Max	额定电流 Idc(A) Max
FHW0805UFR12 \square ST	0.12@25.2MHz	10,5	15@25.2MHz	1000	0.200	800
FHW0805UFR15 \square ST	0.15@25.2MHz	10,5	15@25.2MHz	600	0.300	600
FHW0805UFR18 \square ST	0.18@25.2MHz	10,5	15@25.2MHz	550	0.250	750
FHW0805UFR22 \square ST	0.22@25.2MHz	10,5	15@25.2MHz	500	0.300	700
FHW0805UFR27 \square ST	0.27@25.2MHz	10,5	15@25.2MHz	550	0.350	550
FHW0805UFR33 \square ST	0.33@25.2MHz	10,5	15@25.2MHz	500	0.400	500
FHW0805UFR39 \square ST	0.39@25.2MHz	10,5	12@25.2MHz	500	0.350	550
FHW0805UFR47 \square ST	0.47@25.2MHz	10,5	10@25.2MHz	450	0.400	500
FHW0805UFR56 \square ST	0.56@25.2MHz	10,5	10@25.2MHz	450	0.400	500
FHW0805UFR68 \square ST	0.68@25.2MHz	10,5	10@25.2MHz	400	0.600	500
FHW0805UFR75 \square ST	0.75@25.2MHz	10,5	10@25.2MHz	400	0.700	500
FHW0805UFR82 \square ST	0.82@25.2MHz	10,5	10@25.2MHz	400	0.800	500
FHW0805UF1R0 \square ST	1.0@7.96MHz	10,5	10@7.96MHz	360	1.000	430
FHW0805UF1R2 \square ST	1.2@7.96MHz	10,5	10@7.96MHz	350	1.150	410
FHW0805UF1R5 \square ST	1.5@7.96MHz	10,5	10@7.96MHz	300	1.200	400
FHW0805UF1R8 \square ST	1.8@7.96MHz	10,5	10@7.96MHz	200	1.350	380
FHW0805UF2R2 \square ST	2.2@7.96MHz	10,5	10@7.96MHz	170	1.500	350
FHW0805UF2R7 \square ST	2.7@7.96MHz	10,5	10@7.96MHz	100	1.700	320
FHW0805UF3R3 \square ST	3.3@7.96MHz	10,5	10@7.96MHz	90	1.800	300
FHW0805UF3R9 \square ST	3.9@7.96MHz	10,5	10@7.96MHz	90	1.950	280
FHW0805UF4R7 \square ST	4.7@7.96MHz	10,5	10@7.96MHz	85	2.050	250
FHW0805UF5R6 \square ST	5.6@7.96MHz	10,5	10@7.96MHz	70	2.300	240
FHW0805UF6R8 \square ST	6.8@7.96MHz	10,5	10@7.96MHz	55	2.600	220
FHW0805UF7R5 \square ST	7.5@7.96MHz	10,5	10@7.96MHz	55	2.800	210
FHW0805UF8R2 \square ST	8.2@7.96MHz	10,5	10@7.96MHz	50	3.000	180
FHW0805UF100 \square ST	10@2.52MHz	10,5	8@2.52MHz	30	3.200	150
FHW0805UF120 \square ST	12@2.52MHz	10,5	8@2.52MHz	17	3.500	110
FHW0805UF150 \square ST	15@2.52MHz	10,5	8@2.52MHz	16	4.200	100
FHW0805UF180 \square ST	18@2.52MHz	10,5	8@2.52MHz	15	4.500	95
FHW0805UF220 \square ST	22@2.52MHz	10,5	8@2.52MHz	14	6.000	80

1008Type

型号 Part NO	电感量 Inductance (μ H)	偏差范围 Tolerance	Q 值 Q (Min)	自谐振频率 SRF (MHZ) Min	最大直流电阻 Rdc (Ω) Max	额定电流 Idc(A) Max
FHW1008IFR12 \square ST	0.12@25.2MHz	10,5	12@25.2MHz	850	0.15	800
FHW1008IFR39 \square ST	0.39@25.2MHz	10,5	12@25.2MHz	480	0.29	600
FHW1008IFR47 \square ST	0.47@25.2MHz	10,5	20@25.2MHz	380	0.30	600
FHW1008IFR56 \square ST	0.56@25.2MHz	10,5	12@25.2MHz	330	0.42	600

FHW1008IFR68□ST	0.68@25.2MHz	10,5	12@25.2MHz	330	0.45	600
FHW1008IFR82□ST	0.82@25.2MHz	10,5	12@25.2MHz	300	0.62	600
FHW1008IF1R0□ST	1.0@25.2MHz	10,5	12@25.2MHz	300	0.55	580
FHW1008IF1R2□ST	1.2@7.96MHz	10,5	12@7.96MHz	250	0.75	550
FHW1008IF1R5□ST	1.5@7.96MHz	10,5	12@7.96MHz	230	0.85	400
FHW1008IF1R8□ST	1.8@7.96MHz	10,5	12@7.96MHz	168	0.95	320
FHW1008IF2R2□ST	2.2@7.96MHz	10,5	12@7.96MHz	150	1.30	315
FHW1008IF2R7□ST	2.7@7.96MHz	10,5	12@7.96MHz	100	1.40	300
FHW1008IF3R3□ST	3.3@7.96MHz	10,5	12@7.96MHz	80	1.50	280
FHW1008IF3R9□ST	3.9@7.96MHz	10,5	12@7.96MHz	60	1.55	250
FHW1008IF4R7□ST	4.7@7.96MHz	10,5	12@7.96MHz	50	1.75	210
FHW1008IF5R6□ST	5.6@7.96MHz	10,5	12@7.96MHz	40	1.90	190
FHW1008IF6R8□ST	6.8@7.96MHz	10,5	12@7.96MHz	35	2.00	175
FHW1008IF7R5□ST	7.5@7.96MHz	10,5	12@7.96MHz	30	2.10	170
FHW1008IF8R2□ST	8.2@7.96MHz	10,5	12@7.96MHz	25	2.20	160
FHW1008IF100□ST	10@2.52MHz	10,5	10@2.52MHz	25	2.50	155
FHW1008IF120□ST	12@2.52MHz	10,5	10@2.52MHz	20	2.60	145
FHW1008IF150□ST	15@2.52MHz	10,5	10@2.52MHz	20	3.00	130
FHW1008IF180□ST	18@2.52MHz	10,5	10@2.52MHz	20	3.00	130
FHW1008IF220□ST	22@2.52MHz	10,5	10@2.52MHz	18	3.90	105
FHW1008IF270□ST	27@2.52MHz	10,5	10@2.52MHz	10	4.00	100
FHW1008IF330□ST	33@2.52MHz	10,5	10@2.52MHz	8	4.80	85
FHW1008IF390□ST	39@2.52MHz	10,5	10@2.52MHz	7	5.00	80
FHW1008IF470□ST	47@2.52MHz	10,5	10@2.52MHz	7	5.70	60
FHW1008IF560□ST	56@2.52MHz	10,5	10@2.52MHz	6.5	6.00	55
FHW1008IF680□ST	68@2.52MHz	10,5	10@2.52MHz	6.5	6.70	50
FHW1008IF820□ST	82@2.52MHz	10,5	10@2.52MHz	6.5	7.50	45
FHW1008IF101□ST	100@0.796MHz	10,5	8@0.796MHz	4.5	11.00	40
FHW1008IF121□ST	120@0.796MHz	10,5	8@0.796MHz	3	13.00	30
FHW1008IF151□ST	150@0.796MHz	10,5	8@0.796MHz	3	15.00	25
FHW1008IF221□ST	220@0.796MHz	10	8@0.796MHz	2.5	18.00	20

1210 Type

型号 Part NO	电感量 Inductance (μ H)	偏差范围 Tolerance	Q 值 Q (Min)	自谐振频率 SRF (MHZ) Min	最大直流电阻 Rdc (Ω) Max	额定电流 Idc(A) Max
FHW1210IFR12□ST	0.12@25.2MHz	10,5	20@25.2MHz	850	0.20	450
FHW1210IFR27□ST	0.27@25.2MHz	10,5	20@25.2MHz	700	0.20	450
FHW1210IFR33□ST	0.33@25.2MHz	10,5	20@25.2MHz	520	0.30	450
FHW1210IFR39□ST	0.39@25.2MHz	10,5	20@25.2MHz	500	0.30	450
FHW1210IFR47□ST	0.47@25.2MHz	10,5	20@25.2MHz	480	0.30	450
FHW1210IFR56□ST	0.56@25.2MHz	10,5	20@25.2MHz	450	0.30	450
FHW1210IFR68□ST	0.68@25.2MHz	10,5	20@25.2MHz	400	0.30	450

FHW1210IFR82□ST	0.82@25.2MHz	10,5	20@25.2MHz	350	0.30	450
FHW1210IF1R0□ST	1.0@7.96MHz	10,5	12@7.96MHz	220	0.30	450
FHW1210IF1R2□ST	1.2@7.96MHz	10,5	12@7.96MHz	210	0.30	450
FHW1210IF1R5□ST	1.5@7.96MHz	10,5	12@7.96MHz	200	0.40	450
FHW1210IF1R8□ST	1.8@7.96MHz	10,5	12@7.96MHz	195	0.50	450
FHW1210IF2R2□ST	2.2@7.96MHz	10,5	12@7.96MHz	175	0.60	450
FHW1210IF2R7□ST	2.7@7.96MHz	10,5	12@7.96MHz	120	0.70	420
FHW1210IF3R3□ST	3.3@7.96MHz	10,5	12@7.96MHz	80	1.10	380
FHW1210IF3R9□ST	3.9@7.96MHz	10,5	12@7.96MHz	75	1.20	360
FHW1210IF4R7□ST	4.7@7.96MHz	10,5	12@7.96MHz	60	1.30	350
FHW1210IF5R6□ST	5.6@7.96MHz	10,5	12@7.96MHz	50	2.00	320
FHW1210IF6R8□ST	6.8@7.96MHz	10,5	12@7.96MHz	35	1.50	310
FHW1210IF8R2□ST	8.2@7.96MHz	10,5	12@7.96MHz	35	1.60	305
FHW1210IF100□ST	10@2.52MHz	10,5	10@2.52MHz	30	1.00	300
FHW1210IF120□ST	12@2.52MHz	10,5	10@2.52MHz	25	1.20	265
FHW1210IF150□ST	15@2.52MHz	10,5	10@2.52MHz	22	2.00	225
FHW1210IF180□ST	18@2.52MHz	10,5	10@2.52MHz	22	2.10	210
FHW1210IF220□ST	22@2.52MHz	10,5	10@2.52MHz	20	2.40	200
FHW1210IF270□ST	27@2.52MHz	10,5	10@2.52MHz	18	2.70	180
FHW1210IF330□ST	33@2.52MHz	10,5	10@2.52MHz	15	2.90	160
FHW1210IF390□ST	39@2.52MHz	10,5	10@2.52MHz	16	4.70	150
FHW1210IF470□ST	47@2.52MHz	10,5	10@2.52MHz	10	5.20	140
FHW1210IF560□ST	56@2.52MHz	10,5	10@2.52MHz	8	5.60	125
FHW1210IF680□ST	68@2.52MHz	10,5	10@2.52MHz	5	4.70	110
FHW1210IF820□ST	82@2.52MHz	10,5	10@2.52MHz	5	5.60	100
FHW1210IF101□ST	100@0.796MHz	10,5	8@0.796MHz	5	6.80	95
FHW1210IF121□ST	120@0.796MHz	10,5	8@0.796MHz	4	7.90	85
FHW1210IF151□ST	150@0.796MHz	10,5	8@0.796MHz	4	9.00	80
FHW1210IF181□ST	180@0.796MHz	10,5	8@0.796MHz	3	14.50	70
FHW1210IF221□ST	220@0.796MHz	10,5	8@0.796MHz	2.6	16.50	65
FHW1210IF271□ST	270@0.796MHz	10	8@0.796MHz	2.5	18.00	60
FHW1210IF331□ST	330@0.796MHz	10	8@0.796MHz	2.3	19.00	55
FHW1210IF391□ST	390@0.796MHz	10	8@0.796MHz	2.2	21.50	45
FHW1210IF471□ST	470@0.796MHz	10	8@0.796MHz	2	22.50	40
FHW1210IF561□ST	560@0.796MHz	10	6@0.796MHz	1.5	28.00	30

1812 Type

型号 Part NO	电感量 Inductance (nH)	偏差范围 Tolerance	Q 值 Q (Min)	自谐振频率 SRF (MHZ) Min	最大直流电阻 Rdc (Ω) Max	额定电流 Idc(A) Max
FHW1812IFR33□ST	0.33@25.2MHz	10,5	10@25.2MHz	380	0.13	1000
FHW1812IFR47□ST	0.47@25.2MHz	10,5	10@25.2MHz	330	0.14	1000
FHW1812IFR56□ST	0.56@25.2MHz	10,5	10@25.2MHz	300	0.15	1000

FHW1812IFR82□ST	0.82@25.2MHz	10,5	10@25.2MHz	250	0.20	1000
FHW1812IF1R0□ST	1.0@7.96MHz	10,5	15@7.96MHz	200	0.22	1000
FHW1812IF1R2□ST	1.2@7.96MHz	10,5	15@7.96MHz	200	0.35	1000
FHW1812IF1R5□ST	1.5@7.96MHz	10,5	15@7.96MHz	180	0.32	1000
FHW1812IF1R8□ST	1.8@7.96MHz	10,5	15@7.96MHz	160	0.35	950
FHW1812IF2R2□ST	2.2@7.96MHz	10,5	15@7.96MHz	150	0.37	900
FHW1812IF2R7□ST	2.7@7.96MHz	10,5	15@7.96MHz	145	0.37	850
FHW1812IF3R3□ST	3.3@7.96MHz	10,5	15@7.96MHz	140	0.48	800
FHW1812IF3R9□ST	3.9@7.96MHz	10,5	15@7.96MHz	135	0.60	750
FHW1812IF4R7□ST	4.7@7.96MHz	10,5	15@7.96MHz	120	1.00	700
FHW1812IF5R6□ST	5.6@7.96MHz	10,5	15@7.96MHz	110	0.55	650
FHW1812IF6R8□ST	6.8@7.96MHz	10,5	15@7.96MHz	80	0.80	600
FHW1812IF8R2□ST	8.2@7.96MHz	10,5	15@7.96MHz	70	0.85	600
FHW1812IF100□ST	10@2.52MHz	10,5	10@2.52MHz	60	1.00	550
FHW1812IF120□ST	12@2.52MHz	10,5	10@2.52MHz	55	1.10	550
FHW1812IF150□ST	15@2.52MHz	10,5	10@2.52MHz	35	1.20	500
FHW1812IF180□ST	18@2.52MHz	10,5	10@2.52MHz	29	1.20	500
FHW1812IF220□ST	22@2.52MHz	10,5	10@2.52MHz	20	1.30	450
FHW1812IF270□ST	27@2.52MHz	10,5	10@2.52MHz	20	1.50	400
FHW1812IF330□ST	33@2.52MHz	10,5	10@2.52MHz	18	1.70	350
FHW1812IF390□ST	39@2.52MHz	10,5	10@2.52MHz	14	1.80	350
FHW1812IF470□ST	47@2.52MHz	10,5	10@2.52MHz	10	2.00	300
FHW1812IF560□ST	56@2.52MHz	10,5	10@2.52MHz	10	2.20	290
FHW1812IF680□ST	68@2.52MHz	10,5	10@2.52MHz	5.4	2.40	260
FHW1812IF820□ST	82@2.52MHz	10,5	10@2.52MHz	5.2	2.80	240
FHW1812IF101□ST	100@0.796MHz	10,5	10@0.796MHz	4	3.00	220
FHW1812IF121□ST	120@0.796MHz	10,5	10@0.796MHz	3.3	3.30	220
FHW1812IF151□ST	150@0.796MHz	10,5	10@0.796MHz	3	3.70	200
FHW1812IF181□ST	180@0.796MHz	10,5	10@0.796MHz	3	4.50	200
FHW1812IF221□ST	220@0.796MHz	10,5	10@0.796MHz	2.5	8.00	170
FHW1812IF271□ST	270@0.796MHz	10,5	10@0.796MHz	2.2	8.50	160
FHW1812IF331□ST	330@0.796MHz	10	10@0.796MHz	2	9.00	150
FHW1812IF391□ST	390@0.796MHz	10	10@0.796MHz	1.8	9.50	130
FHW1812IF471□ST	470@0.796MHz	10	8@0.796MHz	1.6	12.00	120
FHW1812IF561□ST	560@0.796MHz	10	8@0.796MHz	1.5	12.50	110
FHW1812IF681□ST	680@0.796MHz	10	8@0.796MHz	1.5	14.00	100
FHW1812IF751□ST	750@0.796MHz	10	8@0.796MHz	1.5	14.50	95
FHW1812IF821□ST	820@0.796MHz	10	8@0.796MHz	1.5	15.00	95
FHW1812IF102□ST	1000@0.252MHz	10	6@0.252MHz	1.4	16.50	90

◆可靠性测试方法 Reliability Test Method

序号 No.	项目 Items	要求 Requirements	试验方法及备注 Test Methods and Remarks												
1	可焊性 Solder ability	①外观无可见损伤痕迹; No visible mechanical damage. ②端电极表面焊锡覆盖率。 Electrode surface solder coverage. FHW-UC/HC series: $\geq 80\%$.	在 $245\pm 5^{\circ}\text{C}$ 熔融的焊锡 (96.5%Sn/3.0%Ag/0.5%Cu) 中浸置 5±1s。 Dip pads in flux and dip in solder pot(96.5Sn/3.0Ag/0.5Cu)at $245\pm 5^{\circ}\text{C}$ for 5±1s.												
2	耐焊接热 Resistance to Soldering	①外观无可见损伤痕迹; No visible mechanical damage. ②感量变化不超过±5%; Inductance shall not change more than $\pm 5\%$; ③Q 值变化不超过±10%。 Q shall not change more than $\pm 10\%$.	在 $260\pm 5^{\circ}\text{C}$ 熔融的焊锡 (96.5%Sn/3.0%Ag/0.5%Cu) 中浸置 10±1s。 Dip pads in flux and dip in solder pot(96.5Sn/3.0Ag/0.5Cu)at $260\pm 5^{\circ}\text{C}$ for 10±1s.												
3	振动 Vibration	①外观无可见损伤痕迹; No visible mechanical damage. ②感量变化不超过±5%; Inductance shall not change more than $\pm 5\%$; ③Q 值变化不超过±10%。 Q shall not change more than $\pm 10\%$.	振幅 1.5mm, 频率 10~55Hz, 每个方向(X、Y、Z)保持 2 小时。Inductors shall be subjected to vibration of 1.5mm amplitude frequency 10~55Hz (10Hz to 55Hz to 10Hz in a period of 1 minute) for 2h in each of three(X、Y、Z) axes.												
4	端电极强度 Adhesion of electrode	①试验后端电极无脱落; The end electrode did not fall off after the test. ②外观无可见损伤痕迹。 No visible mechanical damage.	将产品焊在 PCB 板上, 按下图、表所示方向及要求施加作用力。Weld the product on the PCB board, and apply force as shown in the diagram, direction and requirement.  <table border="1" data-bbox="986 1617 1455 1935"> <thead> <tr> <th>尺寸规格 Size</th> <th>施加力要求</th> </tr> </thead> <tbody> <tr> <td>0603UF Series</td> <td>7 N</td> </tr> <tr> <td>0805UF Series</td> <td>13 N</td> </tr> <tr> <td>1008IF And Above Series.</td> <td>20 N</td> </tr> <tr> <td colspan="2">Keep time: (10±1)s</td> </tr> <tr> <td colspan="2">Speed: 1.0 mm/s.</td> </tr> </tbody> </table>	尺寸规格 Size	施加力要求	0603UF Series	7 N	0805UF Series	13 N	1008IF And Above Series.	20 N	Keep time: (10±1)s		Speed: 1.0 mm/s.	
尺寸规格 Size	施加力要求														
0603UF Series	7 N														
0805UF Series	13 N														
1008IF And Above Series.	20 N														
Keep time: (10±1)s															
Speed: 1.0 mm/s.															

5	耐低温 Low temperature resistance	①外观无可见损伤痕迹; No visible mechanical damage. ②感量变化不超过±5%; Inductance shall not change more than ±5%; ③Q 值变化不超过±10%。 Q shall not change more than±10%.	①FHW-UF/IF 系列产品放置于温度-40±2℃的环境中存放 +24 1000 —0 h FHW-UF/IF series shall be subjected to-40±2℃ for 1000 +24 —0 h
6	耐高温 High temperature resistance	①外观无可见损伤痕迹; No visible mechanical damage. ②感量变化不超过±5%; Inductance shall not change more than ±5%; ③Q 值变化不超过±10%。 Q shall not change more than±10%.	①FHW-UF/IF 系列产品放置于温度+85±5℃的环境中存 +24 放 1000 —0 h FHW-UF/IF series shall be subjected to +85±5℃ for1000 +24 —0 h
7	温度冲击 Temperature Shock	①外观无可见损伤痕迹; No visible mechanical damage. ②感量变化不超过±5%; Inductance shall not change more than ±5%; ③Q 值变化不超过±10%。 Q shall not change more than±10%.	①FHW-UF/IF 系列: +85℃ 30分钟 ↔ -40℃ 30分钟, 循环 100 次; FHW-UF/IF series : +85℃ 30minutes ↔ -40℃ 30minutes 100 Cycles.
8	高温负载 High temperature load	①外观无可见损伤痕迹; No visible mechanical damage. ②感量变化不超过±5%; Inductance shall not change more than ±5%; ③Q 值变化不超过±10%。 Q shall not change more than±10%.	①FHW-UF/IF 系列产品加额定电流在 85±2℃温度条件下 +24 存放 1000 —0 h FHW-UF/IF series shall be store at 85±2℃ for 1000 —0 +24 h with rated current applied.
9	恒定湿热 Static Humidity	①外观无可见损伤痕迹; No visible mechanical damage. ②感量变化不超过±5%; Inductance shall not change more than ±5%; ③Q 值变化不超过±10%。 Q shall not change more than±10%.	将电感器放置于湿度 90%~95%,温度 60±2℃的环境中 +24 存放 1000 —0 h Inductors shall be subjected to 90%~95%RH. at 60±2℃ +24 for 1000 —0 h
10	抗弯强度 Bending strength	外观无可见损伤痕迹; No visible mechanical damage.	①将电感器安装于试验基板上; 在垂直方向施加力(如下图 所示)。Install the inductor on the test substrate; Apply force in the vertical direction (as shown below). ②该板应在(1±0.5) mm/s 的弯曲速率向下弯曲(2±0.2) mm, 保持时间(20±1) s。The epoxy plate should bend down to (2±0.2) mm at the bending rate of (1±0.5)

			<p>mm/s, Keep time (20±1) sec.</p>
11	<p>耐溶剂性 Solvent Resistance</p>	<p>①外观无可见损伤痕迹; No visible mechanical damage.</p> <p>②感量变化不超过±5%; Inductance shall not change more than ±5%;</p> <p>③Q 值变化不超过±10%. Q shall not change more than±10%.</p>	<p>将元件浸泡在 23±5°C 的异丙醇溶液中, 保持 5±0.5 分钟。 Soak in the element 23±5°C in isopropyl alcohol solution, keep 5±0.5 min.</p>

◆产品特性曲线图 Product Characteristic Curve

FHW0603 Type.

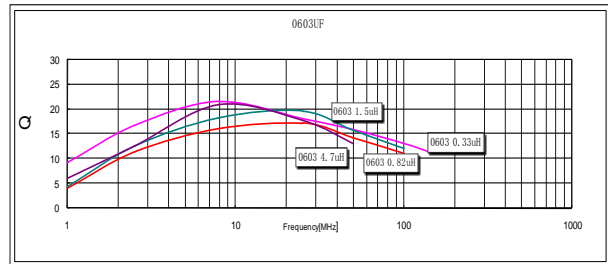
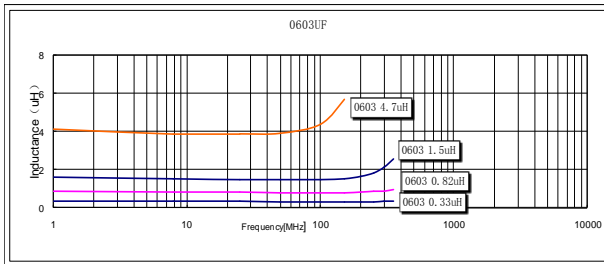

FHW0805 Type.

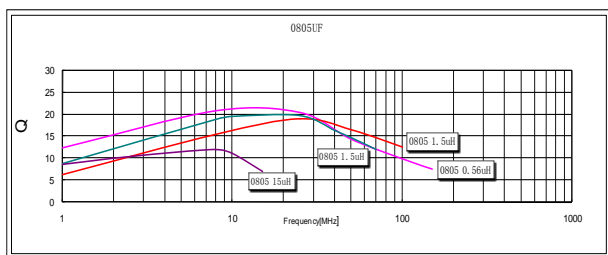
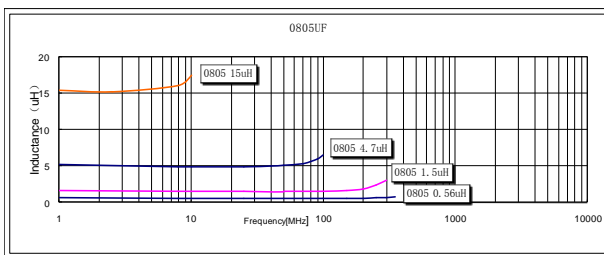

FHW1008 Type.

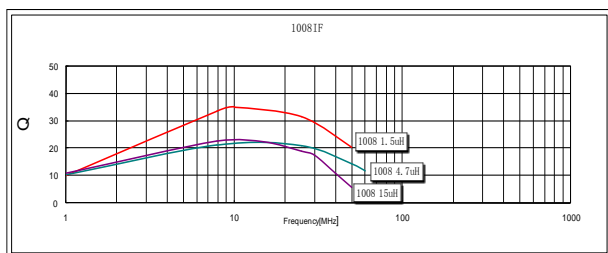
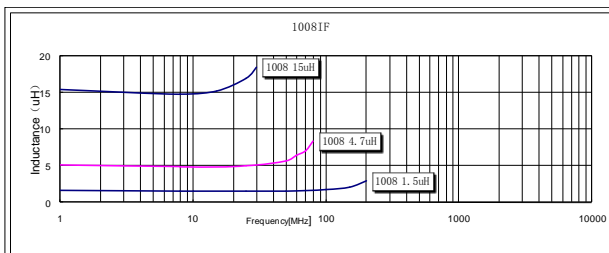

FHW1210 Type.

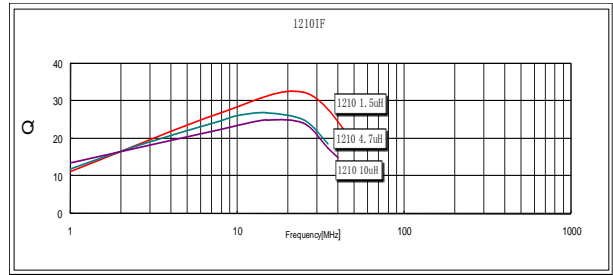
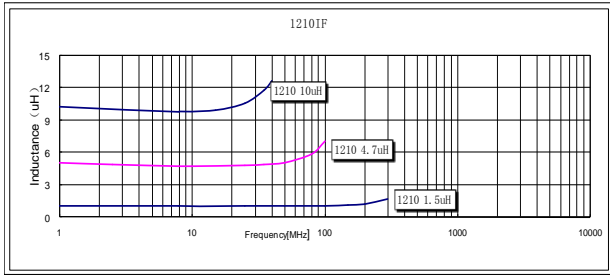

FHW1812 Type.

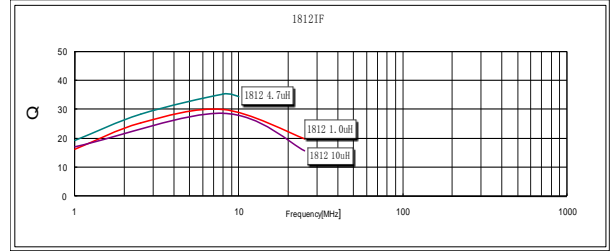
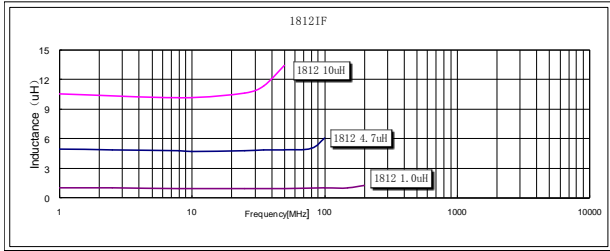

◆包装 Packaging

*编带图 Taping drawings

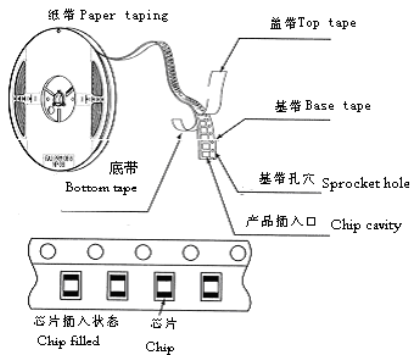

*卷盘尺寸 Reel dimensions (Unit:mm)

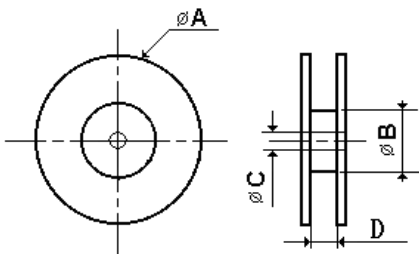

Part NO.	ΦA typ.	ΦB typ.	ΦC typ.	D typ.
0603-1210	178	60	13	8.4
1812	1812	330	98	13

*导带及空格部分 Leader and blank portion

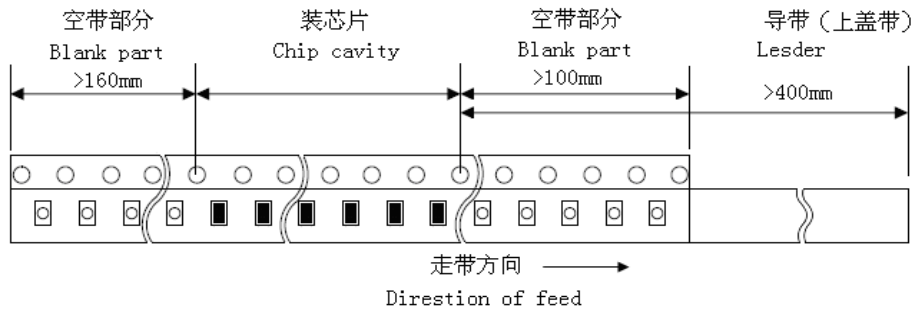

*编带尺寸 Taping dimensions (Unit: mm)

纸带 Paper tape

PAPER TAPE

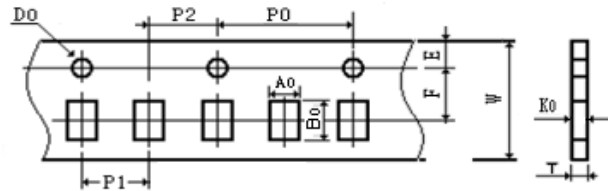

Part NO.	W	E	F	D0	P0	P1	P2	P0x10	A0	B0	T
0603	8.00	1.75	3.50	1.55	4	4	2	40	1.20	1.85	1.00

塑料胶带 EMBOSSED tape

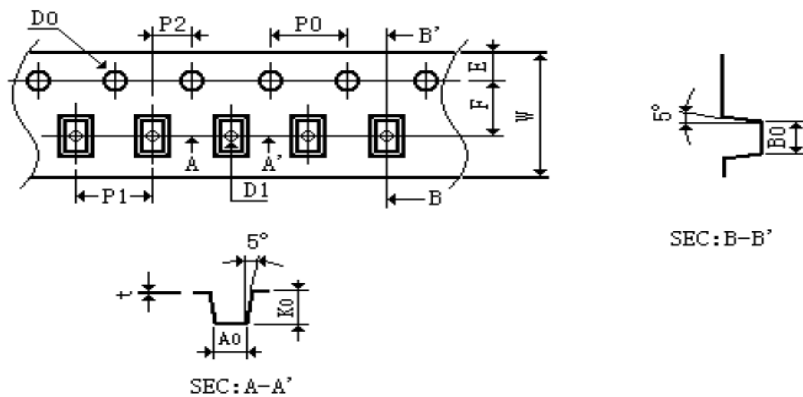

Part NO.	W	E	F	D0	D1	P0	P1	P2	P0x10	t	A0	B0	K0
0805	8.00	1.75	3.50	1.55	0.65	4	4	2	40	0.23	1.85	2.45	1.50
1008	8.00	1.75	3.50	1.55	0.65	4	4	2	40	0.25	2.73	2.90	2.34

1210	8.00	1.75	3.50	1.55	0.65	4	4	2	40	0.23	2.96	3.60	2.40
1812	12.00	1.75	5.50	1.55	1.50	4	8	2	40	0.25	3.22	4.82	2.98

*包装数量 (单位: 粒) Packaging number (Unit: Pcs)

类型 Size		0603	0805	1008	1210	1812
每卷数量 Per Reel		4000	3000	2000	2000	2000
每盒数量 Per Box	3 卷盒	12000	9000	6000	6000	-----
	5 卷盒	20000	15000	10000	10000	10000
每箱数量 Per Case	1.5 盒箱	60000	45000	30000	30000	-----
	2 盒箱	80000	60000	40000	40000	-----
	3 盒箱	120000	90000	60000	60000	-----
	4 盒箱	160000	120000	80000	80000	-----
	6 盒箱	240000	180000	120000	120000	-----
	大 3 盒箱	-----	-----	-----	-----	30000

单击下面可查看定价，库存，交付和生命周期等信息

[>>FH\(风华高科\)](#)