



Thick Film Chip Resistor Arrays
 (Lead-Free for CNC22 Concave Type)
 Halogen-Free

Document No	TCNC-220S002F
Revised Date	2012/07/25
page number	1 / 8

1. Scope :

This specification applies for the CNC22 Concave Type of thick film chip resistor arrays made by TA-I.

2. Construction , Dimensions , Schematic :

2.1 Construction :

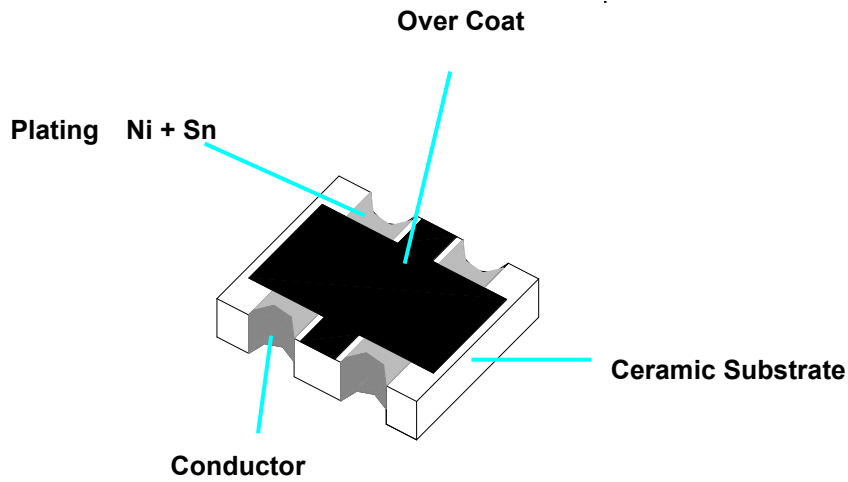

2.1.1 Chip Resistor Arrays :

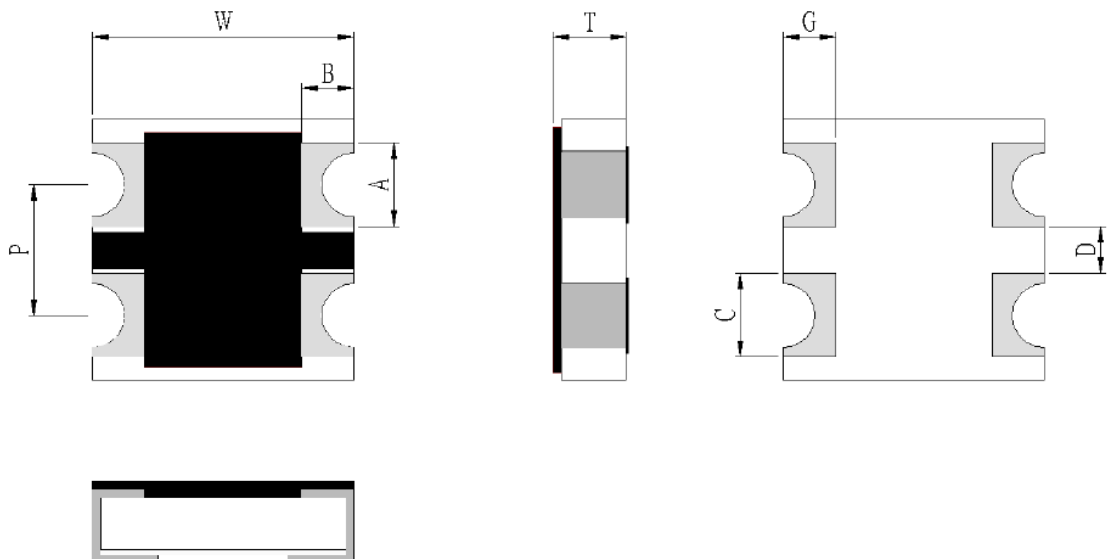

2.2 Dimension :

UNIT:mm

Type	L	W	T	P	A	B	C	D	G
CNC22	1.0±0.1	1.0±0.1	0.3±0.1	0.50±0.1	0.35±0.1	0.25±0.15	0.35±0.1	0.15±0.1	0.25±0.15



Thick Film Chip Resistor Arrays
 (Lead-Free for CNC22 Concave Type)
 Halogen-Free

Document No	TCNC-220S002F
Revised Date	2012/07/25
page number	2 / 8

2.3 Schematic

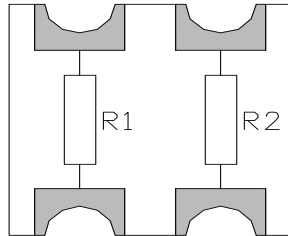

3. Type Designation:

3.1 Chip Resistor Arrays

CNC

22

J

T N

102

Product Code
 CNC:Chip Resistor Arrays
 Concave type

size
Power Rating

Tolerance

Packaging

Nominal Resistance

22-0402*2

J-±5%

T- Paper Tape
 N - Lead Free

3 digits e.g.,:
 (E-24) 102 = 1KΩ



Thick Film Chip Resistor Arrays
 (Lead-Free for CNC22 Concave Type)
 Halogen-Free

Document No	TCNC-220S002F
Revised Date	2012/07/25
page number	3 / 8

4. Ratings & Characteristics :

Type	PowerRating at 70°C	Rating Voltage	Max .Working Voltage	Max. OverLoad Voltage	Operating Temp.(°C)	Resistance Tolerance(%)	Resistance Range (Ω)	Temp Coefficient PPM/°C
CNC22	1/16W	Refer 4.2	25V	50V	-55~+125°C	±5%	10Ω~1MΩ	≤±300

0 Ω THICK FILE CHIP RESISTOR ARRAYS			
Type	Rated Current	Max Overload Current	Resistance Range
CNC 22	1A	2.5A	50mΩ MAX

4.1 Derating Curve :

For resistors operated at ambient temperature over 70°C , power rating shall be derated in accordance with figure 1.

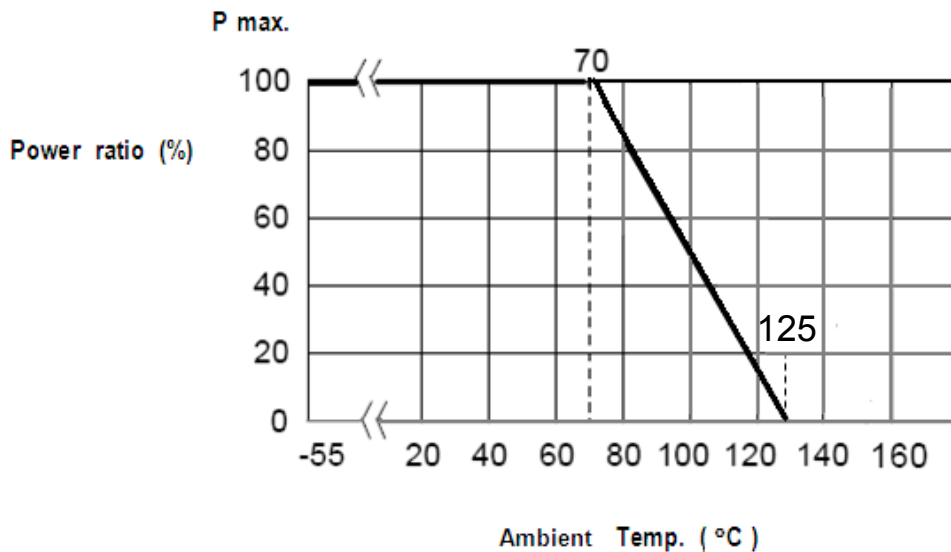

Figure 1

4.2 Rated Voltage:

The rated voltage is calculated by the following formula:

$$E = \sqrt{P * R}$$

E=Rated Voltage(V)
 P=Rated Power(W)
 R=Resistance Value(Ω)

E.G. : What is CNC22JTN102 the rated voltage ?
 CNC22JTN102 P:1/16W ; R:102 = 1KΩ = 1000Ω

$$E = \sqrt{0.0625(W) * 1000(\Omega)} = 7.9 (V)$$



Thick Film Chip Resistor Arrays
(Lead-Free for CNC22 Concave Type)
Halogen-Free

Document No	TCNC-220S002F
Revised Date	2012/07/25
page number	4 / 8

5. Reliability Tests:

Test Items	Reference standard	Condition of Test	Test Limits ($\Delta R/R$)
Temperature Coefficient of Resistance	IEC60115-1-4.8 JIS-C5201-1-4.8	-55 ~ +125 °C	Refer 4.0
Short Time Overload	IEC60115-1-4.13 JIS-C5201-1-4.13	2.5 X rated voltage for 5 sec	$\pm (2.0 \% + 0.1 \Omega)$ 0 Ω : 50m Ω or less
Intermittent Overload	IEC60115-1-4.39 JIS-C5201-1-4.39	2.5X rated voltage or Max Overloading Voltage , 1 sec "ON" 25 sec "OFF" , 10000 cycles	$\pm (5.0 \% + 0.1 \Omega)$ 0 Ω : 50m Ω or less
Load Life	IEC60115-1-4.25.1 JIS-C5201-1-4.25.1	1000 hours at rated voltage , 70°C , 1.5hours "ON " , 0.5hour "OFF"	$\pm (3.0 \% + 0.1 \Omega)$ 0 Ω : 100m Ω or less
Load Life with Humidity	IEC60115-1-4.24 JIS-C5201-1-4.24	1000 hours at rated voltage , 40 \pm 2°C , 90~95% RH 1.5hours "ON " , 0.5hour "OFF"	$\pm (3.0 \% + 0.1 \Omega)$ 0 Ω : 100m Ω or less
Rapid Change of Temperature	IEC60115-1-4.19 JIS-C5201-1-4.19	-55°C (30 min) / +125°C (30 min.) 5 cycles	$\pm (1.0 \% + 0.05 \Omega)$ 0 Ω : 50m Ω or less
Solderability	IEC60115-1-4.17 JIS-C5201-1-4.17	245 \pm 5°C solder, 2 \pm 0.5 sec dwell. Solder : Sn96.5 / Ag3.0 / Cu0.5	At least 95% of surface area of electrode shall be covered with new solder.
Core body	IEC60115-1-4.15 JIS-C5201-1-4.15	Pressure 1.0 kgf a R0.5 pressure rod for 10 sec	Without mechanical damage such as breaks. Electrical characteristic shall be satisfied
Dielectric Withstanding Voltage (Voltage Proof)	IEC60115-1-4.7 JIS-C5201-1-4.7	Applying voltage 100V for 1 minute.	No abnormalities such as flashover, burning dielectric breakdown shall appear.
Resistance to Solder Heat	IEC60115-1-4.18 JIS-C5201-1-4.18	270 \pm 5°C solder , 10 \pm 1 sec dwell .	$\pm (2.0 \% + 0.1 \Omega)$ 0 Ω : 50m Ω or less

Note* : RCWV : Rated continuous working voltage .

6. Marking :

No marking



Thick Film Chip Resistor Arrays
 (Lead-Free for CNC22 Concave Type)
 Halogen-Free

Document No	TCNC-220S002F
Revised Date	2012/07/25
page number	5 / 8

7. Taping & Reel

7.1 Taping Dimensions

7.1.1 2 mm pitch paper

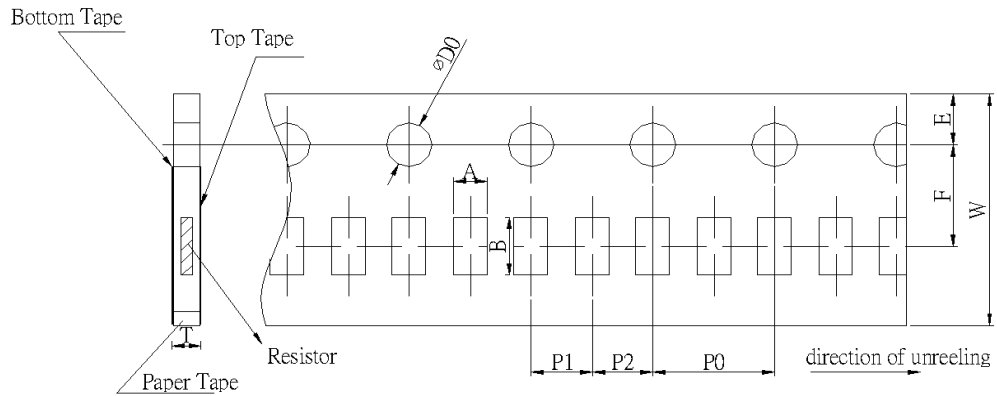

UNIT: mm

Type	A	B	W	F	E	P1	P2	P0	ϕD0	T0
CNC22	1.2 ± 0.1	1.2 ± 0.1	8.0 ± 0.2	3.5 ± 0.1	1.75 ± 0.1	2.0 ± 0.05	2.0 ± 0.05	4.0 ± 0.1	1.5 ± 0.1	0.45 ± 0.1

Package Type	Paper Tape
	2 mm pitch
	178mm / R
CNC22	10000

7.2 Reel Specifications

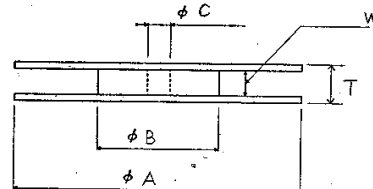
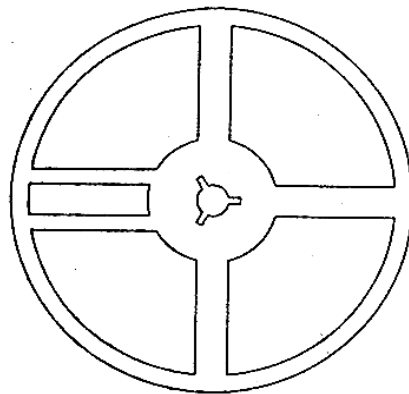

UNIT: mm

Type	ϕA	ϕB	ϕC	W	T
CNC22	178.0 ± 2.0	60 or more	13.0 ± 1.0	9.0 ± 1.0	11.5 ± 1.0



Thick Film Chip Resistor Arrays
 (Lead-Free for CNC22 Concave Type)
 Halogen-Free

Document No	TCNC-220S002F
Revised Date	2012/07/25
page number	6 / 8

7.3 Peel off Strength:

Peel -off force of paper and blister tape is in accordance with "JIS-C5202" that is , 0.1 to 0.7 N at a peel-off speed of 300 mm / minute.

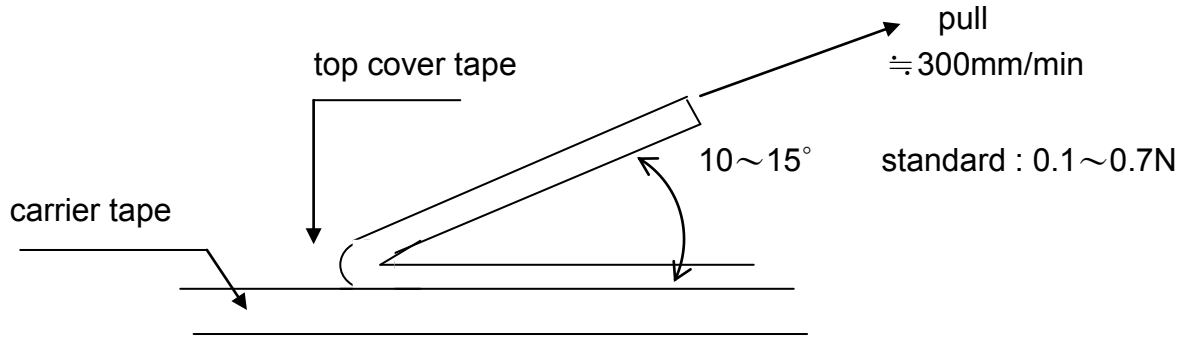

8. Label

8.1 Manufacture Label :

8.1.1 Chip Resistor Arrays

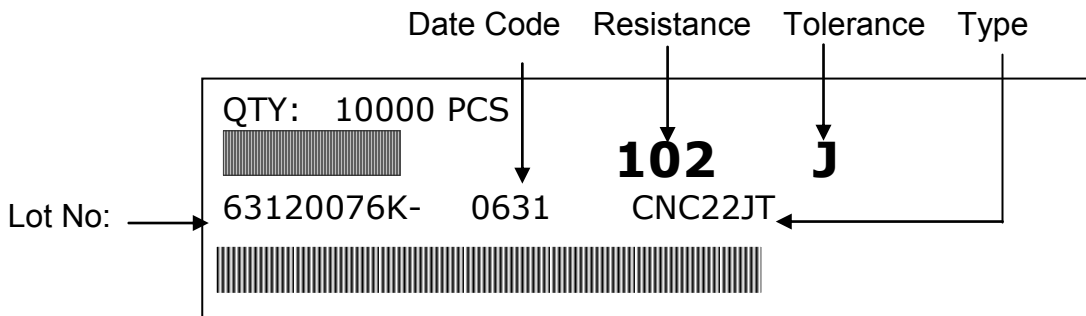

8.2. Customer Label (By customer request) :

8.2.1 Chip Resistor Arrays

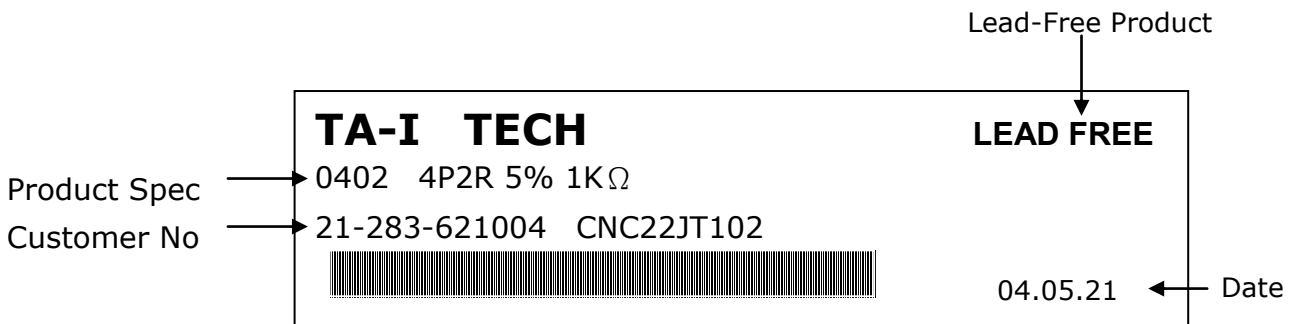



Thick Film Chip Resistor Arrays
 (Lead-Free for CNC22 Concave Type)
 Halogen-Free

Document No	TCNC-220S002F
Revised Date	2012/07/25
page number	7 / 8

9. Recommended land patterns

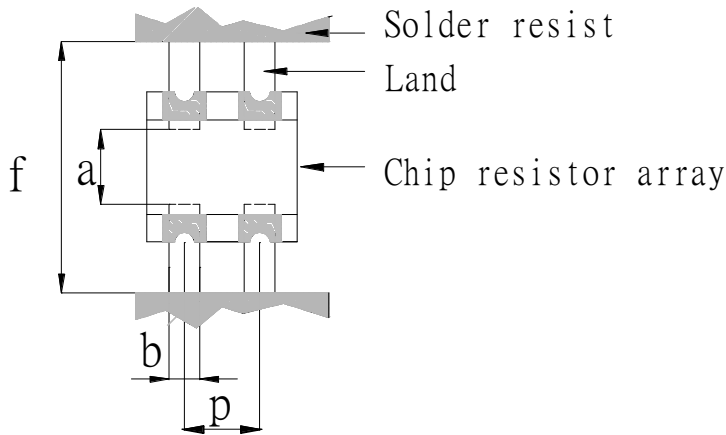

Type	Size	Land pattern	Dimension (mm)			
			a	b	p	f
CNC	22		0.4~0.5	0.25~0.3	0.5	2.0

10. Recommend IR – Reflow profile : (solder : Sn96.5 / Ag3 / Cu0.5)

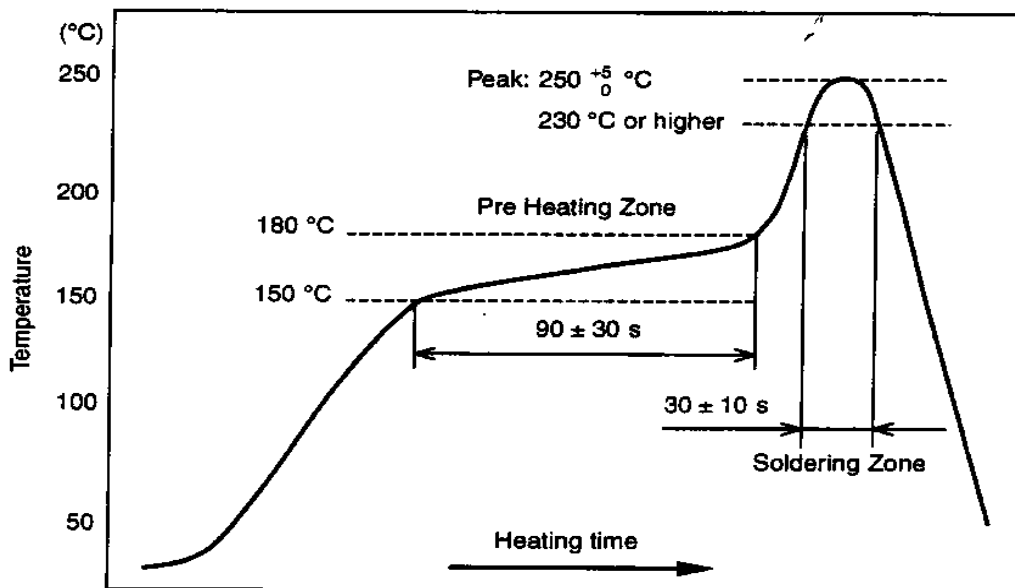

Peak : $250 \begin{matrix} +5 \\ -0 \end{matrix} \text{ } ^\circ\text{C}$, 5 sec
 Pre – heat Zone : 150 to 180 $^\circ\text{C}$, 90 \pm 30 sec
 Soldering Zone : 230 $^\circ\text{C}$ or higher , 30 \pm 10 sec



Thick Film Chip Resistor Arrays
(Lead-Free for CNC22 Concave Type)
Halogen-Free

Document No	TCNC-220S002F
Revised Date	2012/07/25
page number	8 / 8

11. Storage Conditions:

Temperature : 5 to 35 °C
Related Humidity :40 to 75% RH

12. Shelf Life :

2 Years from manufacturing date.

13. ECN :

Engineering Change Notice: The customer will be informed with ECN if there is significant modification on the characteristics and materials described in Approval Sheet.

14. Manufacturing Country & City :

TA-I TECHNOLOGY CO., LTD. (Taiwan – Tao Yuan)
Tel: 886-3-3246169 Fax : 886-3-3246167

Associated companies :

- (1) FORTUNE TASK RESISTOR FACTORY (China - Dongguan)
Tel : 86-769-8339-4790~3 Fax : 86-769-8339-4794
- (2) TA-I TECHNOLOGY (DONGGUAN) CO., LTD. (China - Dongguan)
Tel : 86-769-8339-4790~3 Fax : 86-769-8339-4794
- (3) TA-I TECHNOLOGY (SU ZHOU) CO., LTD. (China - Su Zhou)
Tel :86- 512-63457879 Fax : 86-512-63457869
- (4) TAI OHM ELECTRONICS (M) SDN. BHD. (Malaysia - Pulaupinang)
Tel :604- 3900480 Fax : 604-3901481
- (5) P.T.TAI ELECTRONICS Indonesia (Indonesia - Jakarta)
Tel :62-21-89830123 Fax : 62-21-89830703

单击下面可查看定价，库存，交付和生命周期等信息

[>>TA-I\(大毅\)](#)