



BPSC-12/2/4-M&F Insert

Table of contents

1. INTRODUCTION	2
2. SUPPORTING DOCUMENTS	2
2.1. Customer drawings	2
2.2. Product specification	2
2.3. Application Specification	2
2.4. Rated	2
2.5. Standards	2
3. DESCRIPTION	3
4. REQUIREMENTS	6
4.1. Wire selection and preparation	6
4.1.1. Stripping length L	6
4.1.2. Insulation diameter	7
4.2. Assemble wires to inserts	7
4.2.1. Inserts of crimp termination	7
5. ASSEMBLY	12
5.1. Contact inserts	12
5.2. Marking	14
5.3. Polarization function	14
6. STORAGE	16
6.1. Chemical exposure	16
6.2. Storage condition	16



1. INTRODUCTION

This specification contains the regulations for assembly of **BPSC-12/2/4-M&F** contact inserts and the handling of these inserts.

2. SUPPORTING DOCUMENTS

2.1. Customer drawings

Please refer to the customer drawings of **BPSC-12/2/4-M&F** insert series.

2.2. Product specification

The product specifications of the used articles are to be taken into account. The product specification describes the technical data as e.g. regulations, approvals, temperature range and rated voltage.

For further reference refer Product spec. 108-137664.

2.3. Application Specification

Connectors shall be assembled as below mentioned application specifications to ensure correct connector assembly.

2.4. Rated

- Rated Current / Voltage / Impulse Voltage / Pollution Degree

Signal: 5A 25V 1KV 3

Power 1: 20A 400V 6KV 3; Power 2: 70A 1000V 8KV 3

- Degree of Protection IP00
- Operation temperature -40°C~125°C
- Overvoltage Category III

2.5. Standards

- EN 61984: Connectors - Safety requirements and tests
- IEC 60664-1: Insulation coordination for equipment within low-voltage systems (Part 1)

3. DESCRIPTION

This application specification describes the male insert and the female insert of the **BPSC-12/2/4-M&F**. It should be used inside products with electrical and mechanical protection, otherwise there is a risk of electric shock.

The listed terms are used in the specification as shown **BPSC-12/2/4-M&F** in Figure 1

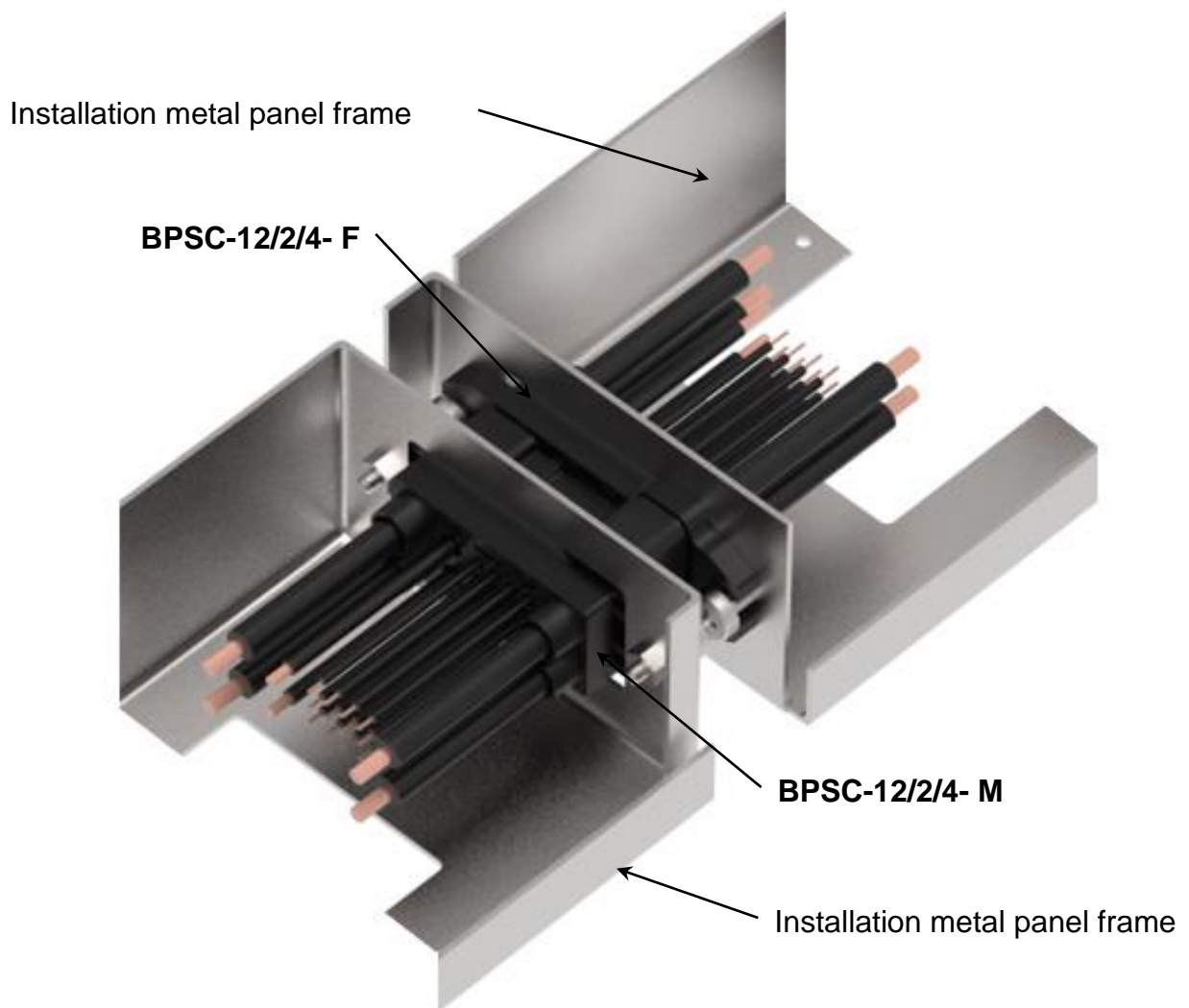

Figure 1: BPSC-12/2/4-M&F application

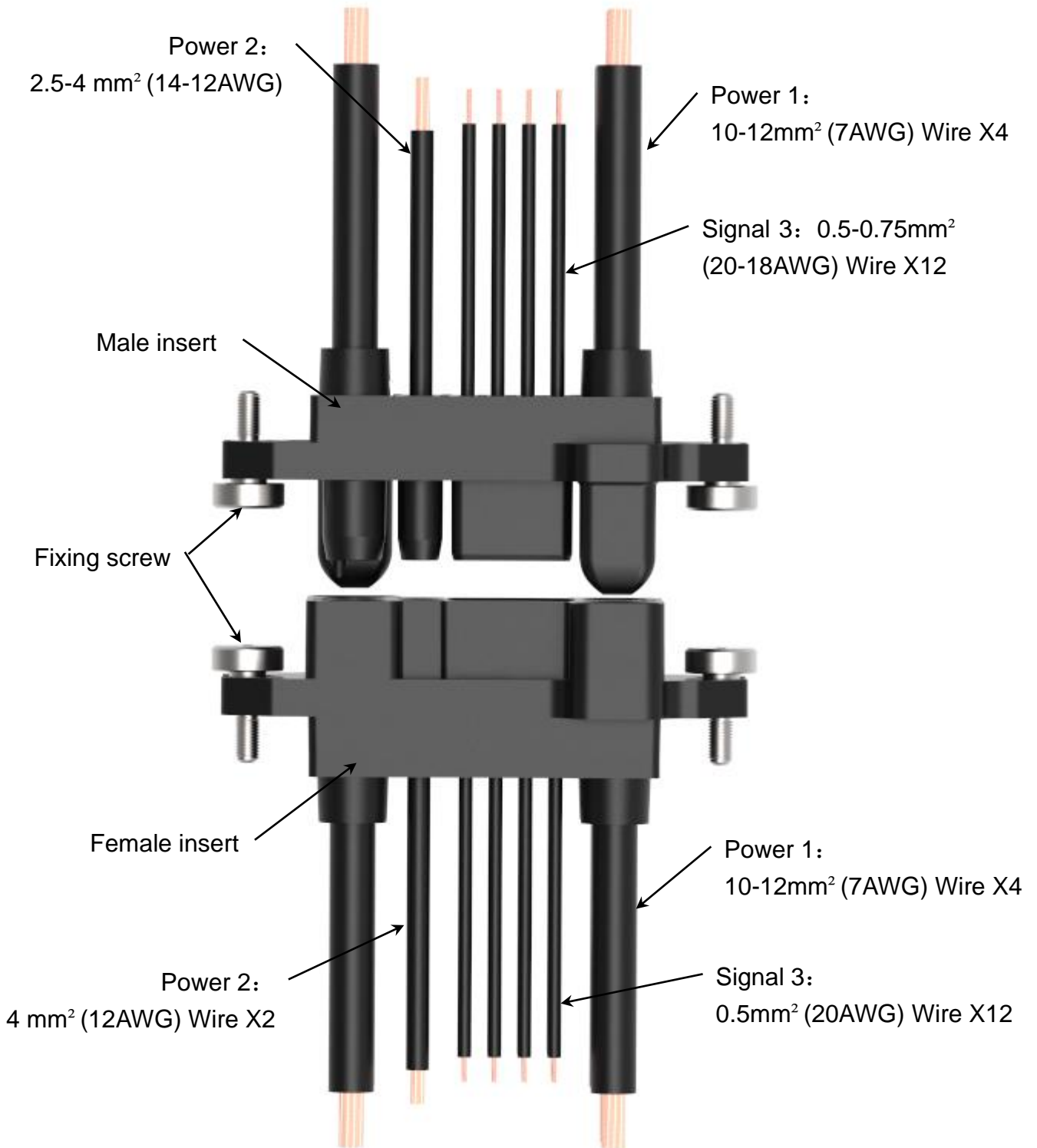

Figure 2



Application Specification

114-137664
Apr 19th, 2023 Rev. A

Contacts order separately					
T3020001005-000	T2210002010-000	T2031001040-000	T2220002040-000	T2410001160-000	T2240002120-000
MDAM-0.5	SDAF0.5-0.75	MCEM-4.0	SCEF2.5-4.0	MCSM10-12	SCSF10-12
					

Notes: after crimping, the distance between conductor and wire insulation jack 1.0mm Max., If distance out of requirements, should use heat shrink tubing to enhance the insulation

4. REQUIREMENTS

4.1. Wire selection and preparation

4.1.1. Stripping length L

Use proper tooling to strip the wire.

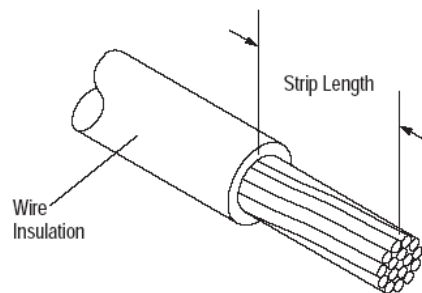

Figure: 3



When stripping the wire, care must be taken to avoid scraping, nicking, or cutting the conductor. Care must also be used when handling the wire during stripping to prevent cracking or breaking the conductor and insulation.

Depending upon the cross section of the wire or cable, the stripping length has to be selected from the table below. See Table 1.

Table: 1

Contact PN	Max. Wire cross section		Strip Length For Reference	Current /Voltage Rating
	[mm ²]	AWG	L [mm]	
T3020001005-000	0.5 mm ²	20	5.5	5A / 25V
T2210002010-000	0.5-0.75 mm ²	20-18	4	5A / 25V
T2031001040-000	4 mm ²	12	8.5	20A / 400V
T2220002040-000	2.5-4 mm ²	14-12	5.5	20A / 400V
T2410001160-000	10-12 mm ²	7	9.5	70A / 1000V
T2240002120-000	10-12 mm ²	7	9	70A / 1000V



4.1.2. Insulation diameter

Any wire that is used for the Electrical purpose is covered with insulating polymer. This insulation on the wires depends upon the wire size and type of application where it is being used. The insulation diameter for various wire sizes is as shown in table 2 only for reference.

Table: 2

Contact Insert	Max. Wire cross section		Insulation Diameter in (mm)
	[mm ²]	AWG	
T3020001005-000	0.5 mm ²	20	2.5 MAX.
T2210002010-000	0.5-0.75 mm ²	20-18	2.5 MAX.
T2031001040-000	4 mm ²	12	4.0 MAX.
T2220002040-000	2.5-4 mm ²	14-12	4.0 MAX.
T2410001160-000	10-12 mm ²	7	7.2 MAX.
T2240002120-000	10-12 mm ²	7	7.2 MAX.

NOTE  The Insulation diameter over the wire specified in the table 2 is for the insulation concentric, with equal thickness layer over the conducting wire.

4.2. Assemble wires to inserts

4.2.1. Inserts of crimp termination

- a. Assemble stripped wires to contacts (Refer to below table)



Application Specification

114-137664
Apr 19th, 2023 Rev. A

Contact crimping guidelines

ITEM	PART NUMBER	TYPE	CROSS SECTION CHECKING	BEFORE CRIMPING	AFTER CRIMPING	TERMINAL FORCE IEC 60352	WITHDRAWAL TOOL
1	T3020001005-000	MDAM-0.5				≥60N @0.5 ϕ	
2	T2210002010-000	SPAF0.5-0.75				≥60N @0.5 ϕ ≥85N @0.75 ϕ	
3	T2031001040-000	MCEM-4.0				≥310N @4 ϕ	
4	T2220002040-000	SCEF2.5-4.0				≥230N @2.5 ϕ ≥310N @4 ϕ	
5	T2410001160-000	MCSM10-12				≥380N @10 ϕ ≥456N @12 ϕ	
6	T2240002120-000	SCSF10-12				≥380N @10 ϕ ≥456N @12 ϕ	

NOTES: Above crimping process only for guideline reference

Notes: for 5A and 20A stamping contacts, should manually adjust the spring after withdrawal from the Insert with remove tool, to ensure the correct mating when make assembly with insert again

NOTE For more detailed information, please refer to related contacts application specifications.

- b. Insert crimped terminals into inserts and remove contact

The crimped terminals are plugged into the insert by gently pushing it into the required position until the contact is locked by the inserts, a click should be heard normally.

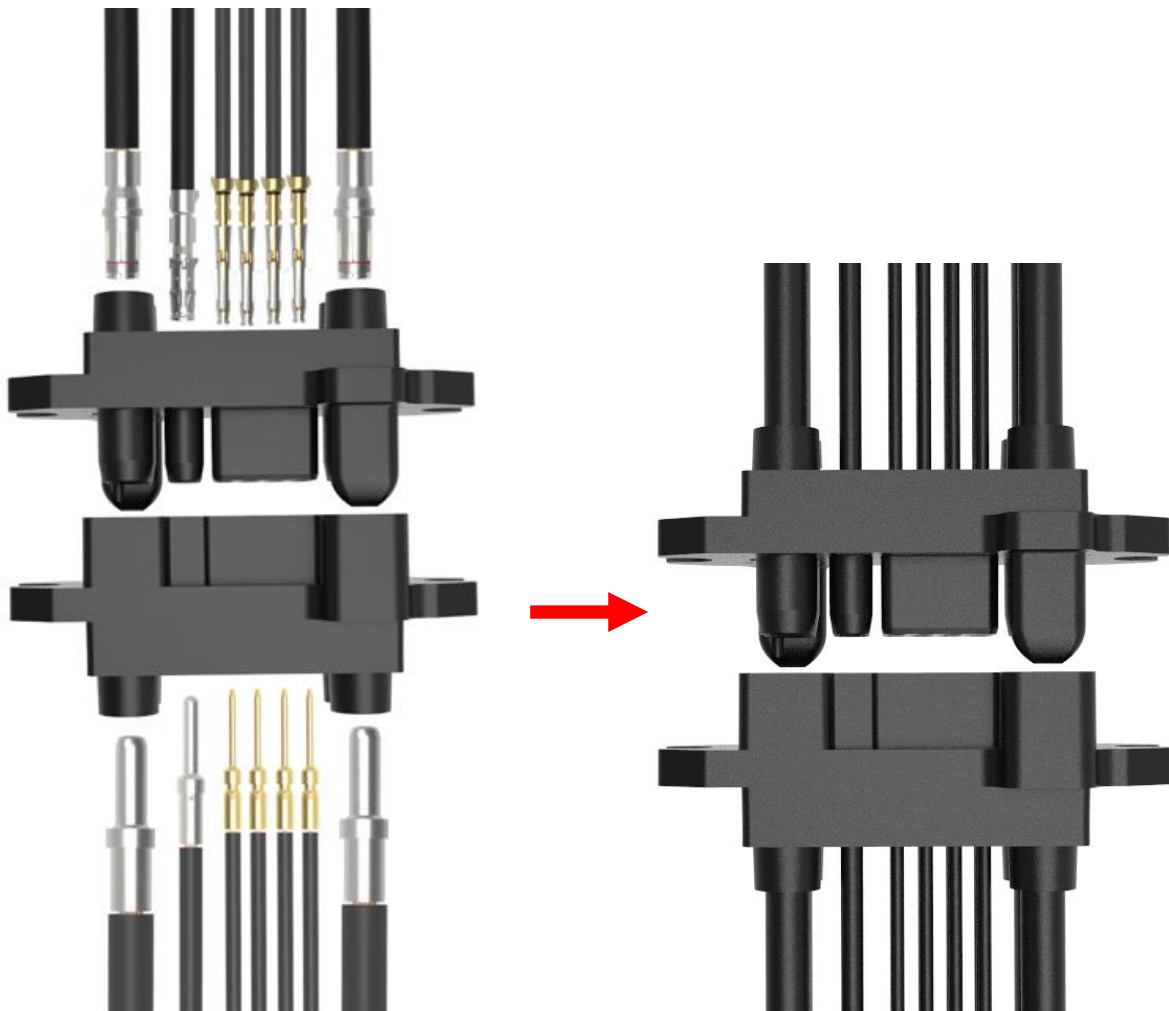
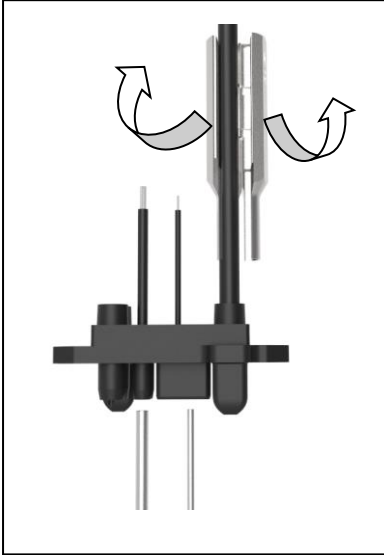
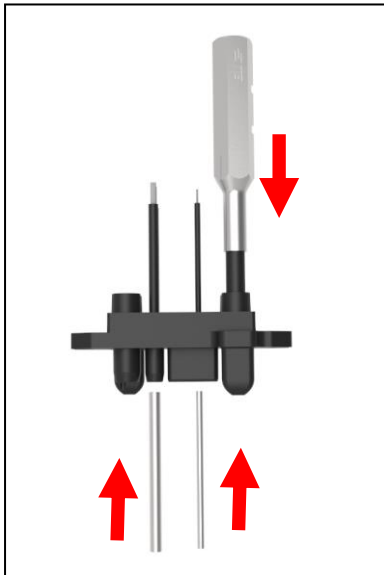

Figure 4: BPSC-12/2/4-M&F contacts assembly with insert

Remove the contacts from insert with withdrawal tool as below:



Step1: Open the remove tool and put wire in



Step2: Close the remove tool and move the tool into the insert hole

**Figure 5: BPSC-12/2/4-F
remove contacts**

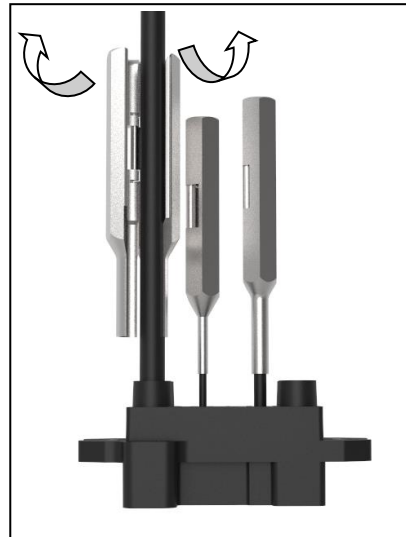

Step1: Open the remove tool and put wire in

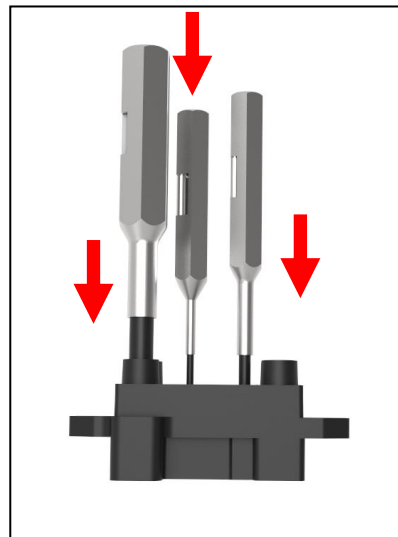

Step2: Close the remove tool and move the tool into the insert hole

**Figure 6: BPSC-12/2/4-M
remove contacts**

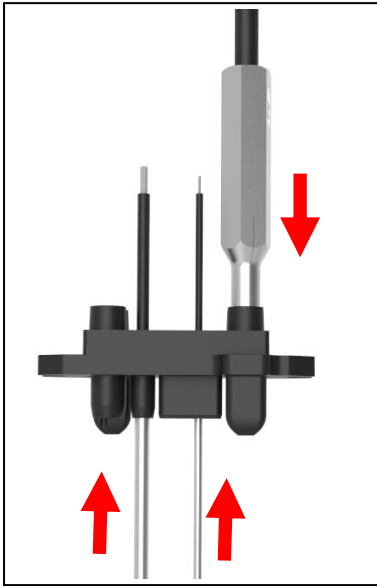

Step3: Move the tool into the bottom of the hole

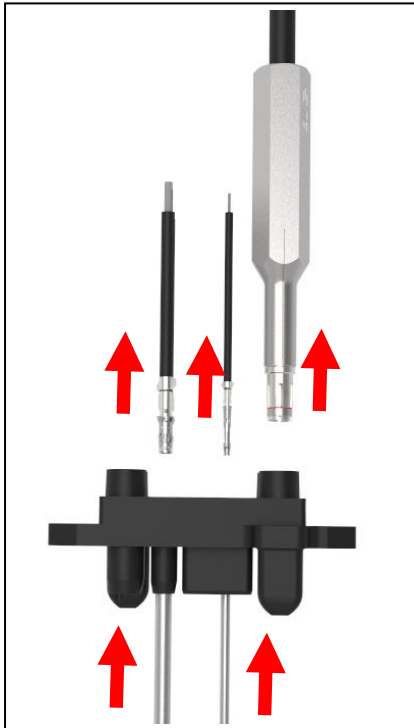

Step4: Pull and remove the contact out of insert

**Figure 7: BPSC-12/2/4-F
remove contacts**

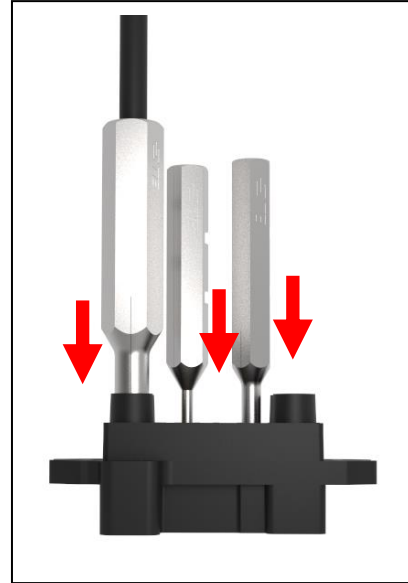

Step3: Move the tool into the bottom of the hole

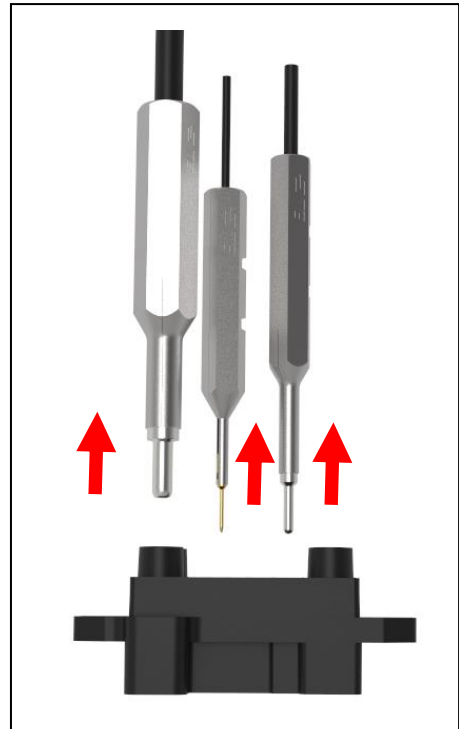

Step4: Pull and remove the contact out of insert

**Figure 8: BPSC-12/2/4-M
remove contacts**

5. ASSEMBLY

Use the proper tool to assembly the inserts with panel and wire should be keep free after assembly, the MAX. floating between M4 screw and insert is $\pm 1.2\text{mm}$

5.1. Contact inserts

The inserts are screwed into a corresponding panel by M4 screws. The torque is 1.2Nm for reference.

Note: “*” The recommend distance between the installation panel. 25.4(+0.5/0)mm.
Installation as shown Figure 9 and Figure 10、 Figure 11



Figure 9: BPSC-12/2/4-F

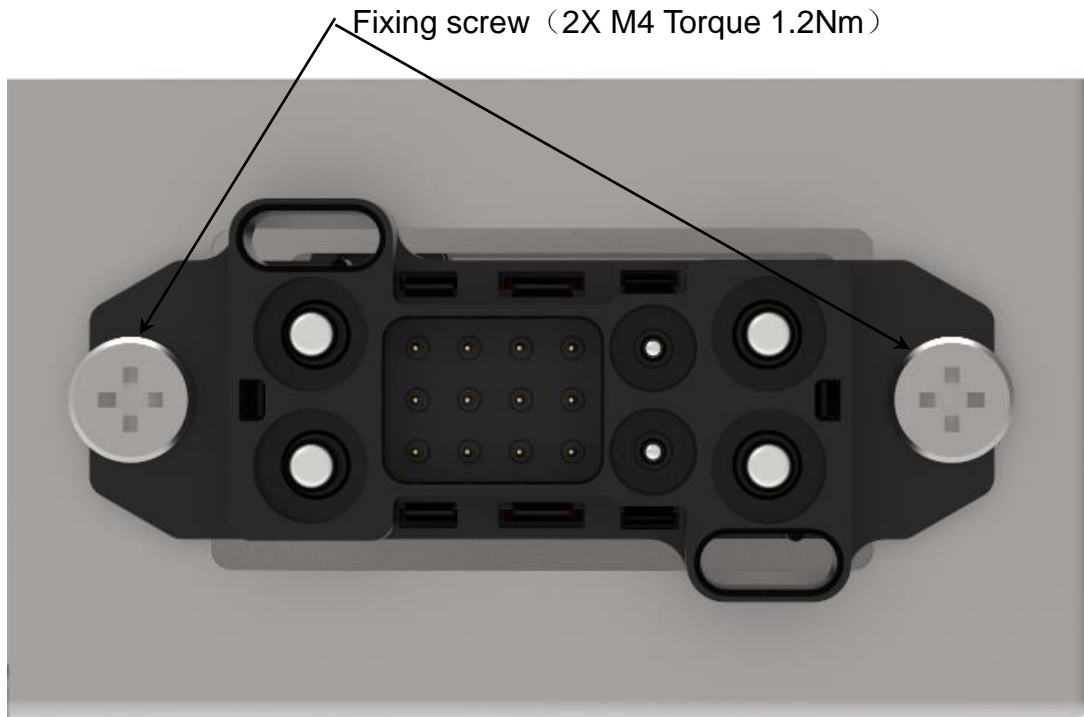

Figure 10: BPSC-12/2/4-M

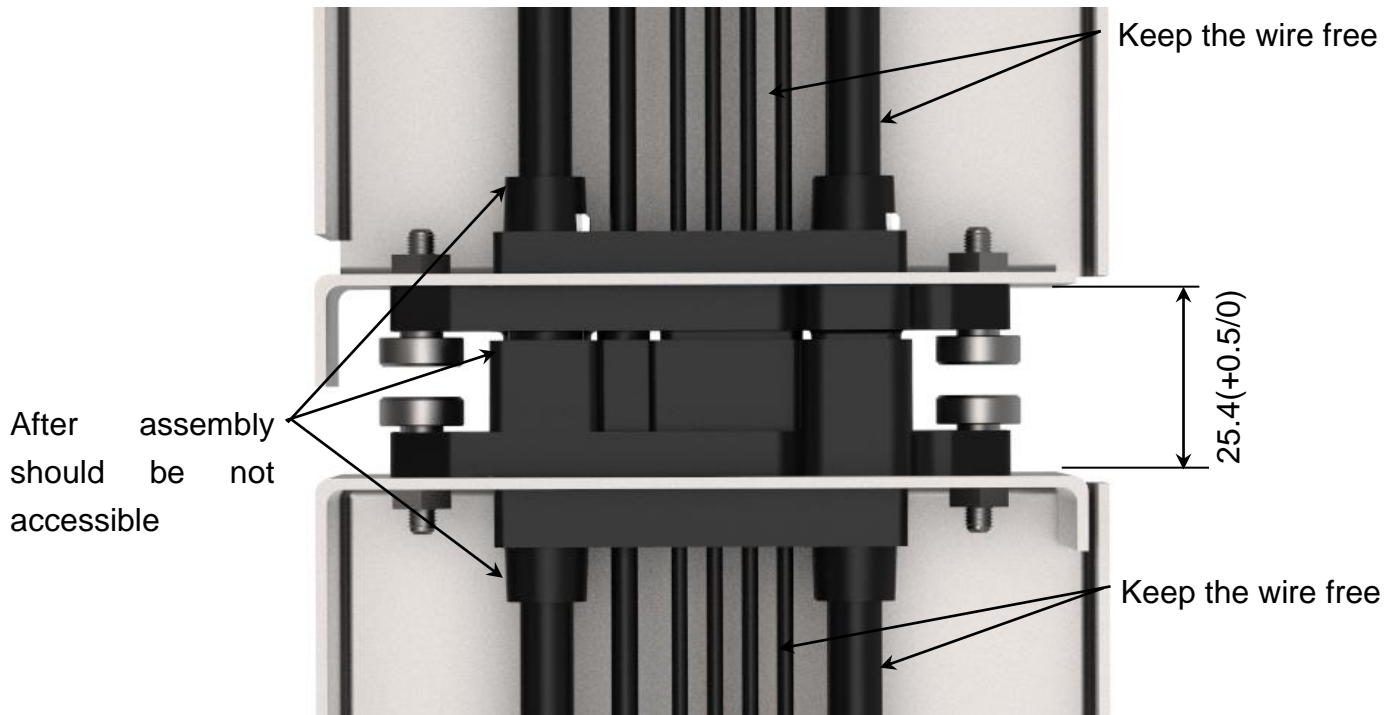

Figure 11: Panel distance

◆ Information for panel cut-out:

Information concerning the panel cut-out for assembly of the contact inserts without housings can be taken from the customer drawings. Panel cut-out as shown in Figure 12.

Panel cut-out dimension for BPSC-12/2/4-M&F

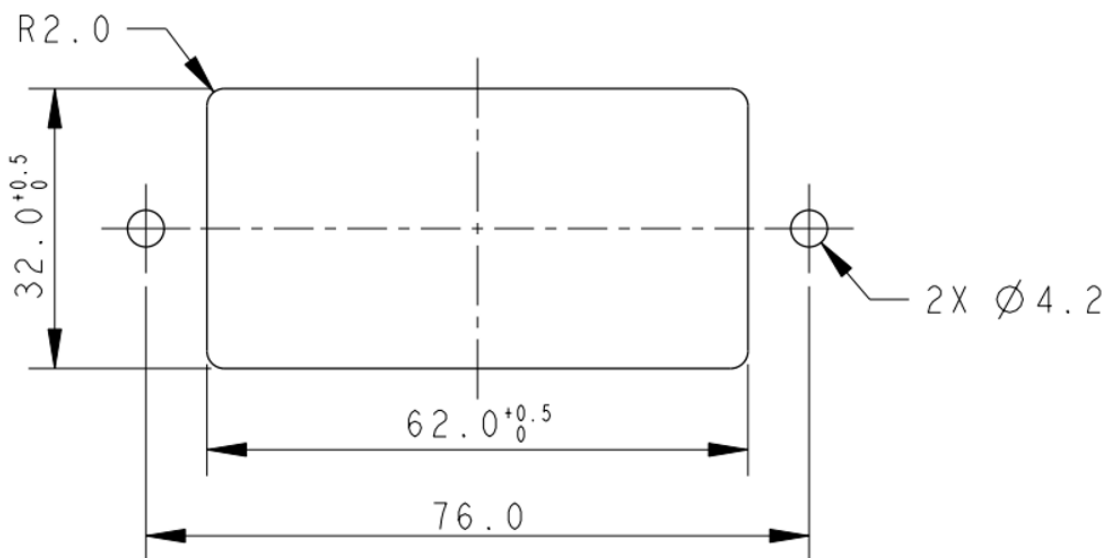

Figure 12: recommended panel cut off dimension

5.2. Marking

The connector type, rating and the number of position etc. refer to the corresponding BPSC-12/2/4 insert customer drawings.

5.3. Polarization function

The process of assembling the male and female inserts without any mismatch and difficulty calls for polarization. This is done with the help of ribs or slots and which are present on both the male insert as well as the female insert. As shown in Figure 13 and Figure 14

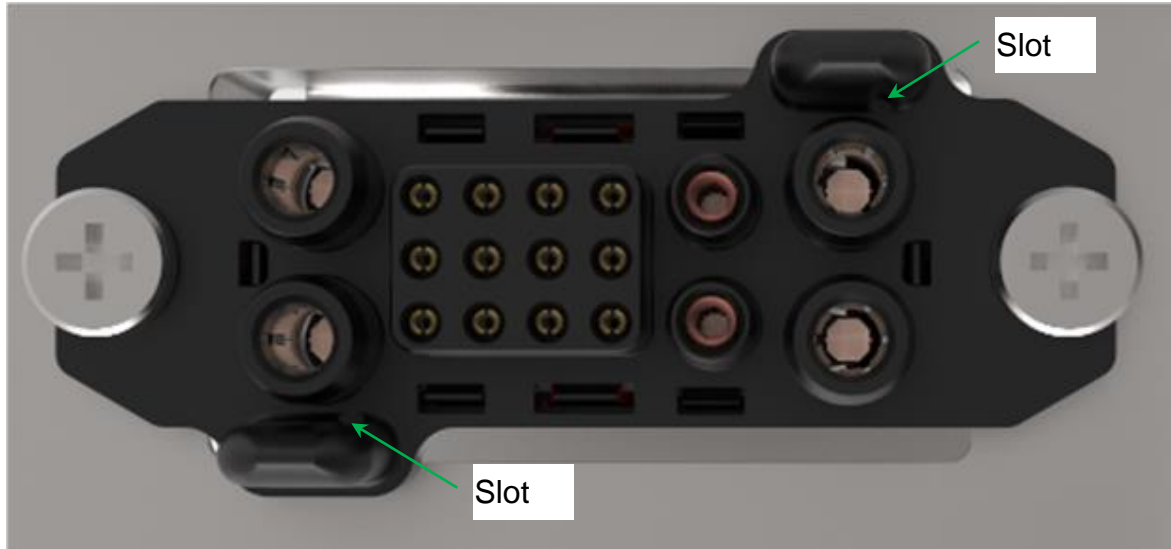

Figure 13: BPSC-12/2/4-F

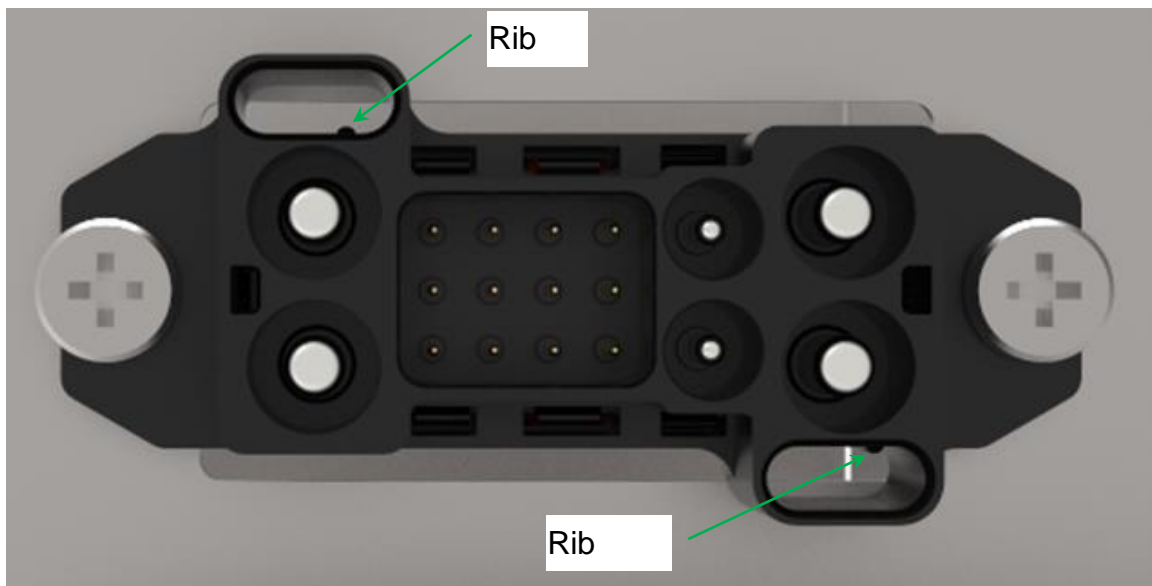

Figure 14: BPSC-12/2/4-M



6. STORAGE

6.1. Chemical exposure

Do not store the connectors near any chemical listed below as they may cause corrosion stress the connector contacts:

Alkalies, Ammonia, Citrates, Phosphates, Citrates, Sulfur, Amines, Carbonates, Nitrites, Sulfides, Nitrites, Tart rates.

6.2. Storage condition

The connectors should be stored in the air ventilation, no corrosive gas, no rain and no snow in the warehouse. Relative humidity: less than 85% RH. The connectors should remain in the shipping containers until ready for use to prevent deformation to the contacts. The connectors should be used on a first in, first out basis to avoid storage contamination that could adversely affect electrical functions.

-----END-----

单击下面可查看定价，库存，交付和生命周期等信息

[>>TE Connectivity\(泰科\)](#)