

GigaDevice Semiconductor Inc.

GD30LD1000x
2A, 6.5V, Low Input Voltage, LDO

Datasheet

Table of Contents

Table of Contents	2
List of Figures	4
List of Tables	5
1 Features	6
2 Applications	6
3 General description	6
4 Device overview	7
4.1 Device information	7
4.2 Block diagram.....	7
4.3 Pinout and pin assignment	8
4.4 Pin definitions.....	8
5 Functional description	10
5.1 Output Voltage Setting	10
5.2 Chip Enable Operation.....	10
5.3 Recommended device selection	10
5.3.1 C _{IN} and C _{OUT} Selection.....	10
5.3.2 Feed-Forward Capacitor(C _{FF}) Selection	11
5.4 Undervoltage Lockout (UVLO)	11
5.5 Power Dissipation (P _D).....	12
6 Electrical characteristics	13
6.1 Absolute maximum ratings	13
6.2 Recommended Operating Conditions.....	13
6.3 Electrical sensitivity	14
6.4 Electrical Specifications	14
6.5 Typical Characteristics	16
7 Typical application circuit	24
8 Layout guideline	25
9 Package information	26
9.1 SOP8 package outline dimensions.....	26
9.2 TO263 package outline dimensions	28



9.3	Thermal characteristics	30
10	Ordering information	31
11	Revision history	32

List of Figures

Figure 4-1 Block diagram for GD30LD1000x	7
Figure 4-2 GD30LD1000x SOP8 pinouts	8
Figure 4-3 GD30LD1000x TO263 pinouts	8
Figure 5-1 Typical UVLO Operation	11
Figure 7-1 Typical GD30LD1000x application circuit with adjustable resistance.....	24
Figure 8-1 Typical GD30LD1000x(SOP8) layout guideline	25
Figure 8-2 Typical GD30LD1000x(TO263) layout guideline.....	25
Figure 9-1 SOP8 package outline.....	26
Figure 9-2 SOP8 recommend Footprint	27
Figure 9-3 TO263 package outline	28
Figure 9-4 TO263 recommend Footprint	29

List of Tables

Table 4-1 Device information for GD30LD1000x	7
Table 4-2 GD30LD1000x pin definitions	8
Table 5-1 Typical UVLO Operation Description	11
Table 6-1 Absolute maximum ratings	13
Table 6-2 Recommended Operating Conditions	13
Table 6-3 Electrostatic Discharge characteristics.....	14
Table 6-4 Electrical characteristics.....	14
Table 7-1 Adjusted V_{OUT} by external feedback resistor.....	24
Table 9-1 SOP8 package dimensions(in mm).....	26
Table 9-2 TO263 package dimensions(in mm)	28
Table 9-3 SOP8 Package thermal characteristics ⁽¹⁾	30
Table 9-4 TO263 Package thermal characteristics ⁽¹⁾	30
Table 10-1 Part ordering code for GD30LD1000x devices.....	31
Table 11-1 Revision history	32

1 Features

- Input Voltage Range, 1.4 V to 6.5 V
- Output Voltage Range, 0.5 V to 5.2 V, Set by a Resistor Divider
- Accurate Output Voltage Accuracy: 1%, Over Line, Load and Temperature
- Ultra Low Dropout Voltage: Maximum 300 mV at 2A
- Load and Temperature
- Current Limit Function
- Short Circuit Protection
- Enable Function

2 Applications

- Wireless Infrastructure
- Telecom/Networking Cards
- Industrial Application
- Set Top Box
- Medical Equipment
- Notebook Computers
- Battery Powered Systems

3 General description

The GD30LD1000x is a high-current, high accuracy, low-dropout linear regulator (LDO) capable of sourcing 2A with extreme low dropout (max, 300mV).

The device output voltage is adjustable from 0.5 V to 5.2 V using the external resistor divider. The device supports input supply voltage as low to 1.4 V. Additionally, the GD30LD1000x has an enable pin to further reduce power dissipation while shutdown.

The GD30LD1000x provides excellent regulation over variations in line, load and temperature. The output voltage can be set by an external divider depending on how the FB pin is configured.

The device is fully specified over the temperature range of $T_J = -40^{\circ}\text{C}$ to 125°C and is offered in the SOP8(Exposed Pad) package or TO263(Exposed Pad) package.

4 Device overview

4.1 Device information

Table 4-1 Device information for GD30LD1000x

Part Number	Package	Function	Description
GD30LD1000x	SOP8	With enable pin(EN)	2A Low input voltage, low dropout LDO regulator
	TO263		

4.2 Block diagram

Figure 4-1 Block diagram for GD30LD1000x

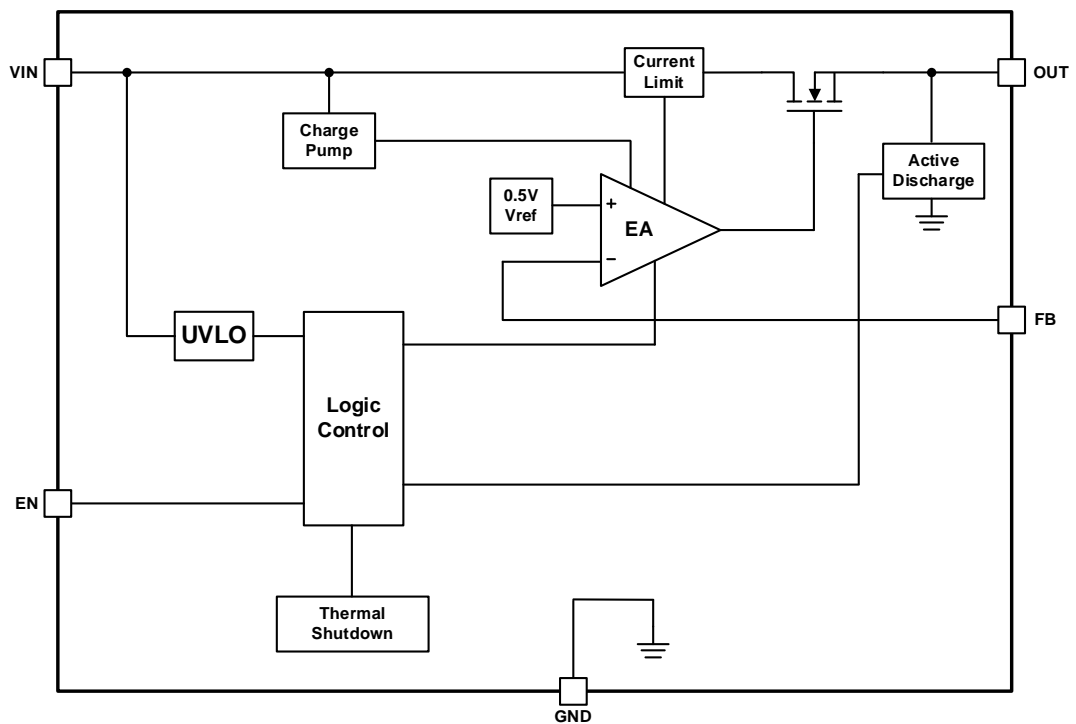

4.3 Pinout and pin assignment

Figure 4-2 GD30LD1000x SOP8 pinouts

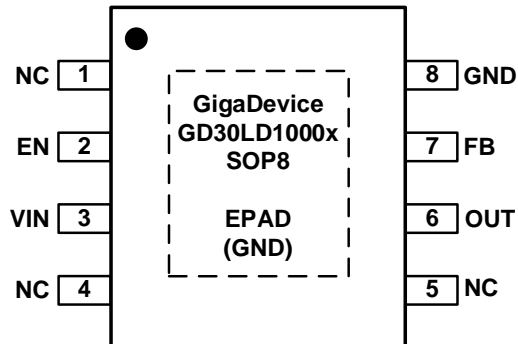
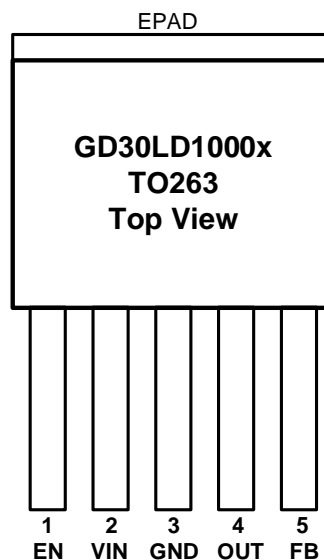

Figure 4-3 GD30LD1000x TO263 pinouts



4.4 Pin definitions

Table 4-2 GD30LD1000x pin definitions

Pin Name	Pins		Pin Type	Functions description
	SOP8	TO263		
NC	1,4,5	—	—	These pins are not connected to silicon.
EN	2	1	I	Enable Control Input. Connecting this pin to logic high enables the regulator, and driving this pin low puts it into shutdown mode.
VIN	3	2	I	Supply Input. A minimum of 10 μ F ceramic capacitor should be placed as close as possible to this pin for better noise rejection.

Pin Name	Pins		Pin Type	Functions description
	SOP8	TO263		
OUT	6	4	O	Output of the Regulator. A minimum of 10 μ F ceramic capacitor should be placed at this pin. The larger ceramic capacitor (10 μ F or greater) is stable.
FB	7	5	I	Feedback Voltage Input. This pin is used to set the desired output voltage via an external resistive divider. The feedback reference voltage is 0.5V typically.
GND	8	3	G	Ground. The exposed pad must be soldered to a large PCB and connected to GND for maximum power dissipation.
GND	9(EPAD)	6(EPAD)	G	Device power ground.

Notes:

1. Type: I = input, O = output, G = Ground.

5 Functional description

5.1 Output Voltage Setting

The output voltage of the GD30LD1000x can be set by external resistors to achieve different output targets.

By using external resistors, the output voltage is determined by the values of R1 and R2 as shown in [Figure 7-1](#). The values of R1 and R2 can be calculated for any voltage value using the following formula:

$$V_{\text{OUT}} = V_{\text{FB}} \times \left(1 + \frac{R_1}{R_2} \right)$$

5.2 Chip Enable Operation

The GD30LD1000x goes into sleep mode when the EN pin is in a logic low condition. In this condition, the pass transistor, error amplifier, and band gap are all turned off, reducing the supply current to only 25uA(max). The EN pin can be directly tied to keep the part on.

5.3 Recommended device selection

5.3.1 C_{IN} and C_{OUT} Selection

The GD30LD1000x is designed to support low-series resistance (ESR) ceramic capacitors. It is recommended to use ceramic capacitors with X7R, X5R, and C0G-rated ceramic capacitors to get good capacitive stability across different temperatures.

However, the capacitance of ceramic capacitors varies with operating voltage and temperature, and the design engineer must be aware of these characteristics. Ceramic capacitors are usually recommended to be derated by 50%. A 10μF or greater output ceramic capacitor is suggested to ensure stability. Input capacitance is selected to minimize transient input drop during load current steps. For general applications, an input capacitor of at least 10μF is highly recommended for minimal input impedance. If the trace inductance between the GD30LD1000x input pin and power supply is high, a fast load transient can cause V_{IN} voltage level ringing above the absolute maximum voltage rating which damages the device. Adding more input capacitors is available to restrict the ringing and keep it below the device absolute maximum ratings.

Generally, a 10μF 0805-sized ceramic capacitor in parallel with two 10μF 0805-sized ceramic capacitor ensures the minimum effective capacitance at high input voltage and high output voltage requirement. Place these capacitors as close to the pins as possible for

optimum performance and to ensure stability.

5.3.2 Feed-Forward Capacitor(C_{FF}) Selection

Although a feed-forward capacitor (C_{FF}) from the FB pin to the OUT pin is not required to achieve stability, a 10nF external feed-forward capacitor optimizes the transient, noise, and PSRR performance. A higher capacitance C_{FF} can be used; however, the start-up time is longer and the power-good signal can incorrectly indicate that the output voltage is settled.

5.4 Undervoltage Lockout (UVLO)

The UVLO circuits ensure that the device stays disabled before its input reach the minimum operational voltage range, and ensures that the device properly shuts down when either the input collapses. Figure 5-1 and Table 5-1 explain one of the UVLO circuits being triggered to various input voltage events, assuming $V_{EN} \geq V_{IH(EN)}$.

Figure 5-1 Typical UVLO Operation

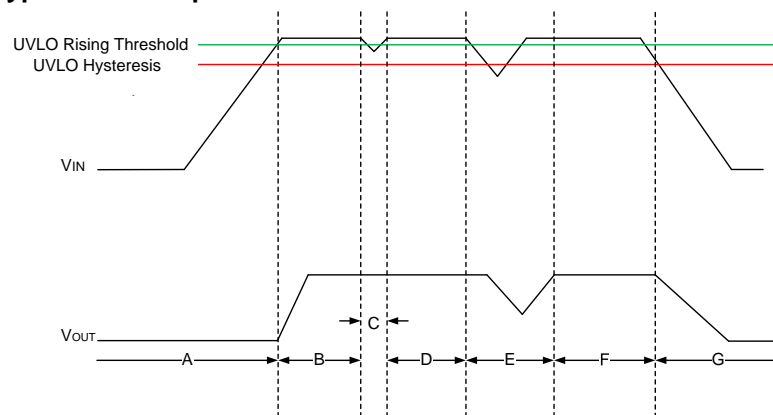

Table 5-1 Typical UVLO Operation Description

Region	EVENT	VOUT STATUS	COMMENT
A	Turn on, $V_{IN} \geq V_{UVLO_1,2(IN)}$ and	Off	Startup
B	Regulation	On	Regulates to target V_{OUT}
C	Brown out, $V_{IN} \geq V_{UVLO_1,2(IN)} - V_{HYS_1,2(IN)}$	On	The output can fall out of regulation but the device is still enabled
D	Regulation	On	Regulates to target V_{OUT}
E	Brown out $V_{IN} < V_{UVLO(IN)} - V_{HYS(IN)}$	Off	The device is disabled and the output falls because of the load and active discharge circuit. The device is reenabled when the UVLO fault is removed when either the IN rising

			threshold is reached by the input a normal start-up then follows
F	Regulation	On	Regulates to target V_{OUT}
G	Turn off, $V_{IN} < V_{UVLO(IN)} - V_{HYS(IN)}$	Off	The output falls because of the load and active discharge circuit.

Similar to many other LDOs with this feature, the UVLO circuits take a few microseconds to fully assert. During this time, a downward line transient below approximately 0.8V causes the UVLO to assert for a short time; however, the UVLO circuits do not have enough stored energy to fully discharge the internal circuits inside of the device. When the UVLO circuits are not given enough time to fully discharge the internal nodes, the outputs are not fully disabled.

The effect of the downward line transient can be mitigated by using a larger input capacitor to increase the fall time of the input supply when operating near the minimum V_{IN} .

5.5 Power Dissipation (P_D)

Circuit reliability demands that proper consideration is given to device power dissipation, location of the circuit on the printed circuit board (PCB), and correct sizing of the thermal plane. The PCB area around the regulator must be as free as possible of other heat-generating devices that cause added thermal stresses.

Power dissipation in the regulator depends on the input-to-output voltage difference and load conditions.

$$P_D = (V_{IN} - V_{OUT}) \times I_{OUT} + V_{IN} \times I_{GND}$$

$V_{IN} \times I_{GND}$ represents the static power consumption of the LDO, the value is relatively small and can be ignored. An important note is that power dissipation can be minimized, and thus greater efficiency achieved, by proper selection of the system voltage rails. Proper selection allows the minimum input-to-output voltage differential to be obtained. The low dropout of the device allows for maximum efficiency across a wide range of output voltages.

The main heat conduction path for the device is through the thermal pad on the package. As such, the thermal pad must be soldered to a copper pad area under the device. This pad area contains an array of plated vias that conduct heat to any inner plane areas or to a bottom-side copper plane.

The maximum power dissipation determines the maximum allowable junction temperature (T_J) for the device. Power dissipation and junction temperature are most often related by the junction-to-ambient thermal resistance (θ_{JA}) of the combined PCB, device package, and the temperature of the ambient air (T_A).

$$T_J = T_A + \theta_{JA} \times P_D$$

$$I_{OUT} = (T_J - T_A) / [\theta_{JA} \times (V_{IN} - V_{OUT})]$$

6 Electrical characteristics

6.1 Absolute maximum ratings

The maximum ratings are the limits to which the device can be subjected without permanently damaging the device. Note that the device is not guaranteed to operate properly at the maximum ratings. Exposure to the absolute maximum rating conditions for extended periods may affect device reliability.

Table 6-1 Absolute maximum ratings

Symbol	Parameter	Min	Max	Unit
Voltage	IN, EN, OUT	-0.3	7.0	V
	FB	-0.3	3.6	V
Current	OUT	Internally limited		A
Thermal characteristics				
T _{stg}	Storage temperature	-65	150	°C

6.2 Recommended Operating Conditions

Table 6-2 Recommended Operating Conditions

Symbol	Parameter	Min	Typ	Max	Unit
V _{IN}	Input voltage range	1.4	—	6.5	V
V _{OUT}	Output voltage range	0.5	—	5.2	V
V _{EN}	Enable Voltage range	0	—	6.5	V
I _{OUT}	Output current	0	—	2	A
C _{IN}	Input capacitor	—	10	—	uF
C _{OUT}	Output capacitor	—	10	—	uF
T _J	Operating junction temperature	-40	—	125	°C

6.3 Electrical sensitivity

The device is strained in order to determine its performance in terms of electrical sensitivity. Electrostatic discharges (ESD) are applied directly to the pins of the sample.

Table 6-3 Electrostatic Discharge characteristics

Symbol	Parameter	Conditions	Value	Unit
$V_{ESD(HBM)}$	Electrostatic discharge voltage (human body model)	$T_A = 25\text{ }^\circ\text{C}$; JS-001-2017	± 2000	V
$V_{ESD(CDM)}$	Electrostatic discharge voltage (charge device model)	$T_A = 25\text{ }^\circ\text{C}$; JS-002-2018	± 500	V

6.4 Electrical Specifications

Over operating temperature range ($T_J = -40^\circ\text{C}$ to 125°C), Typical values are at $T_J = 25^\circ\text{C}$. $V_{IN} = 1.4\text{ V}$ or $V_{IN} = V_{OUT(TARGET)} + 0.4\text{ V}$, $V_{OUT(TARGET)} = 0.5\text{ V}$, $V_{EN} = 1.1\text{ V}$, $C_{IN} = 10\text{ }\mu\text{F}$, $C_{OUT} = 10\text{ }\mu\text{F}$, unless otherwise noted.

Table 6-4 Electrical characteristics

Symbol	Parameter	Conditions	Min	Typ	Max	Unit
V_{IN}	Input Range	—	1.4	—	6.5	V
V_{FB}	Feedback Voltage	—	—	0.5	—	V
$V_{UVLO(IN)}$	UVLO	V_{IN} rising	—	1.33	1.39	V
$V_{HYS(IN)}$	UVLO hysteresis	—	—	240	—	mV
V_{OUT}	Output Voltage Range	Using external resistors	0.5 -1%	—	5.2 +1%	V
	Output Accuracy	$V_{IN} = V_{OUT} + 0.3\text{ V}$, $0.5\text{ V} \leq V_{OUT} \leq 5.2\text{ V}$	-1	—	1	%
$\frac{\Delta V_{OUT}}{\Delta V_{IN}}$	Line Regulation	$I_{OUT} = 5\text{ mA}$, $1.4\text{ V} \leq V_{IN} \leq 6.5\text{ V}$	—	0.1	—	mV/V
$\frac{\Delta V_{OUT}}{\Delta I_{OUT}}$	Load Regulation	$5\text{ mA} \leq I_{OUT} \leq 2\text{ A}$	—	0.3	—	mV/A
V_{DROPO}	Dropout Voltage	$V_{IN} = 1.4\text{ V}$, $I_{OUT} = 2\text{ A}$, $V_{FB} = 0.5\text{ V} - 3\%$	—	120	250	mV
		$V_{IN} = 5.6\text{ V}$, $I_{OUT} = 2\text{ A}$, $V_{FB} = 0.5\text{ V} - 3\%$	—	150	300	mV
I_{LIM}	Output Current Limit	$V_{OUT} = 90\% * V_{OUT(TARGET)}$ $V_{IN} = V_{OUT(TARGET)} + 400\text{ mV}$	—	3.0	—	A

Symbol	Parameter	Conditions	Min	Typ	Max	Unit
Short-Circuit Current Limit	I_{SC}	$R_{LOAD} = 20m\Omega$	—	1.0	—	A
I_{GND}	Ground Pin Current	$V_{IN} = 6.5 V, I_{OUT} = 5 mA$	—	3.0	4.2	mA
		$V_{IN} = 1.4 V, I_{OUT} = 2A$	—	4.2	5.5	mA
		Shutdown $V_{IN} = 6.5 V, V_{EN} = 0.5 V$	—	—	25	μA
I_{EN}	EN Pin Current	$V_{IN} = 6.5 V, V_{EN} = 0 V$ and 6.5 V	-0.1	—	0.1	μA
V_{EN_H}	EN Pin High-Level	—	1.1	—	6.5	V
V_{EN_L}	EN Pin Low-Level	—	0	—	0.5	V
I_{FB}	FB Pin leakage Current	$V_{IN} = 6.5 V$	-100	—	100	nA
T_{SD}	Thermal Shutdown Threshold	Shut down, temperature increasing	—	160	—	$^{\circ}C$
		Reset, temperature increasing	—	140	—	$^{\circ}C$

6.5 Typical Characteristics

$T_A = 25^\circ\text{C}$, $V_{IN} = 1.4\text{ V}$ or $V_{IN} = V_{OUT(TARGET)} + 0.4\text{ V}$ (whichever is greater), $V_{OUT(TARGET)} = 0.5\text{ V}$, $V_{EN} = 1.1\text{ V}$, $C_{IN} = 10\ \mu\text{F}$, $C_{OUT} = 10\ \mu\text{F}$, unless otherwise noted.

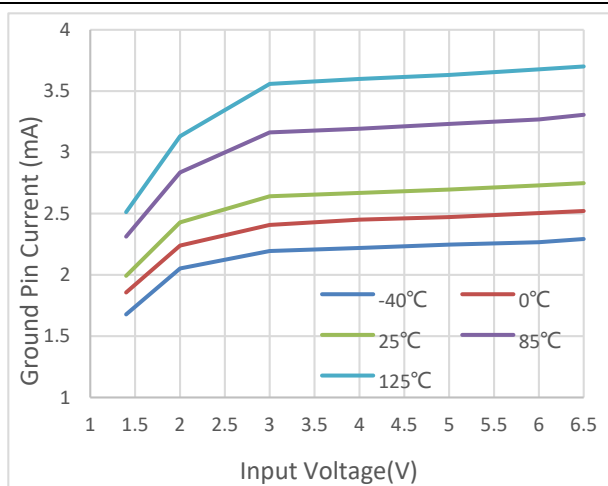

$I_{OUT}=5\text{mA}$

Ground Pin Current vs Input Voltage

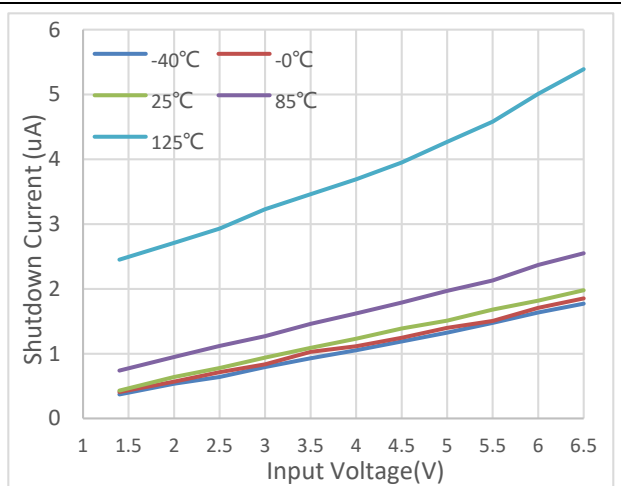

$V_{EN}=0.5\text{V}$

Shutdown Current vs Input Voltage

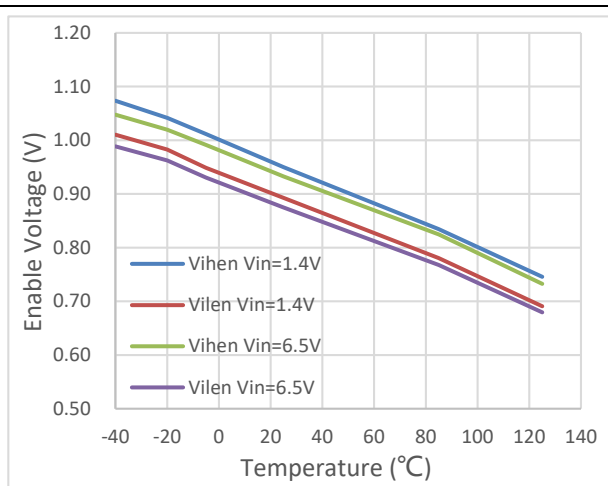

$V_{IN}=1.4\text{V}$ and $V_{IN}=6.5\text{V}$

EN Threshold vs Temperature

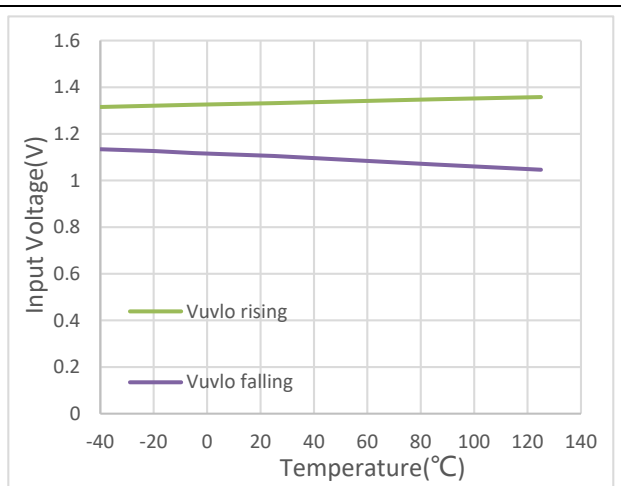

$I_{OUT}=5\text{mA}$

VIN UVLO vs Temperature

Typical Characteristics

$T_A = 25^\circ\text{C}$, $V_{IN} = 1.4\text{ V}$ or $V_{IN} = V_{OUT(TARGET)} + 0.4\text{ V}$ (whichever is greater), $V_{OUT(TARGET)} = 0.5\text{ V}$, $V_{EN} = 1.1\text{ V}$, $C_{IN} = 10\ \mu\text{F}$, $C_{OUT} = 10\ \mu\text{F}$, unless otherwise noted.

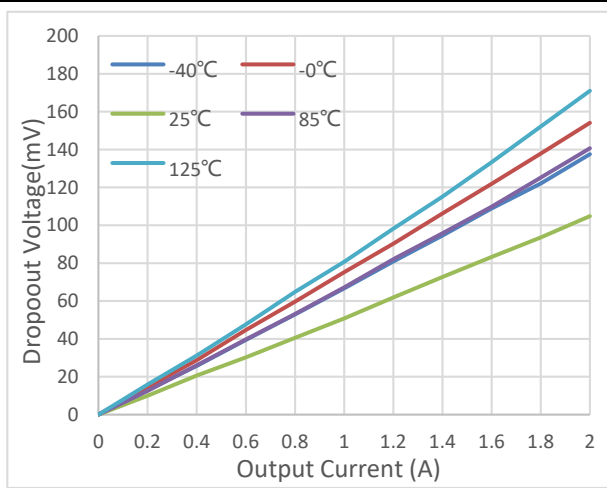

$V_{IN}=1.4\text{V}$

Dropout Voltage vs Output Current

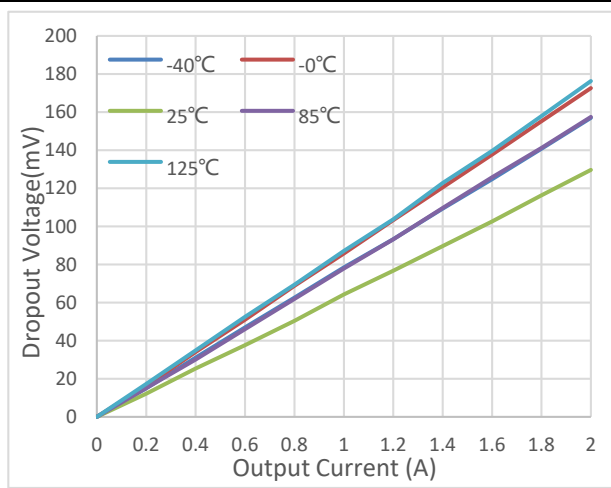

$V_{IN}=5.5\text{V}$

Dropout Voltage vs Output Current

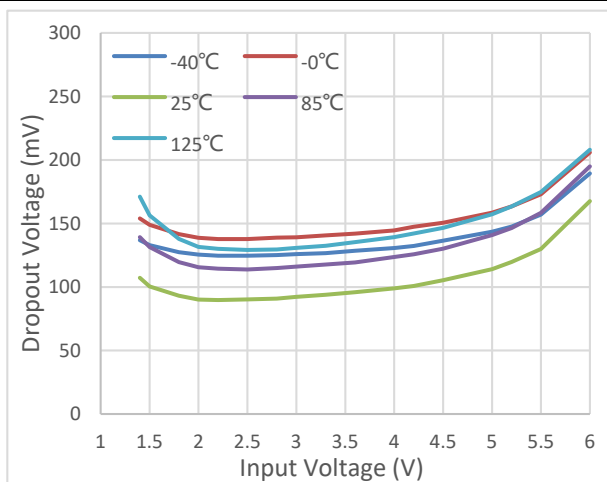

$V_{IN}=5.5\text{V}$, $I_{OUT}=2\text{A}$

Dropout Voltage vs Input Voltage

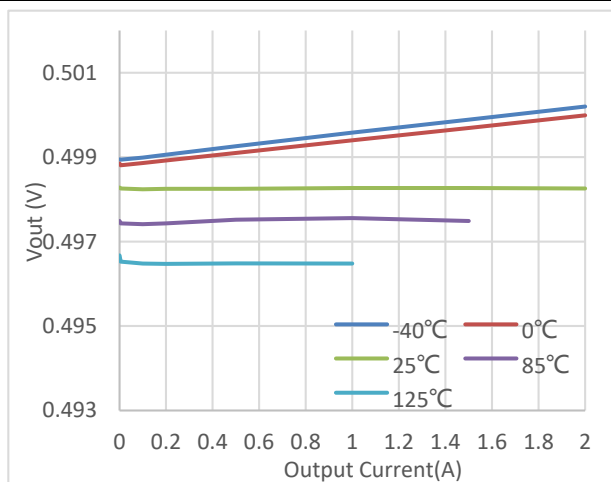

$V_{IN}=1.4\text{V}$, $V_{OUT}=0.5\text{V}$, $OUT=FB$

Output Voltage vs Output Current

Typical Characteristics

$T_A = 25^\circ\text{C}$, $V_{IN} = 1.4\text{ V}$ or $V_{IN} = V_{OUT(TARGET)} + 0.4\text{ V}$ (whichever is greater), $V_{OUT(TARGET)} = 0.5\text{ V}$, $V_{EN} = 1.1\text{ V}$, $C_{IN} = 10\ \mu\text{F}$, $C_{OUT} = 10\ \mu\text{F}$, unless otherwise noted.

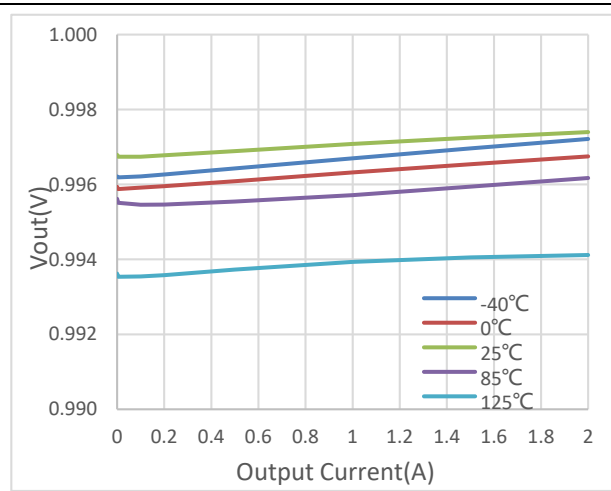

$V_{IN}=1.4\text{V}$, $V_{OUT}=1.0\text{V}$

Output Voltage vs Output Current

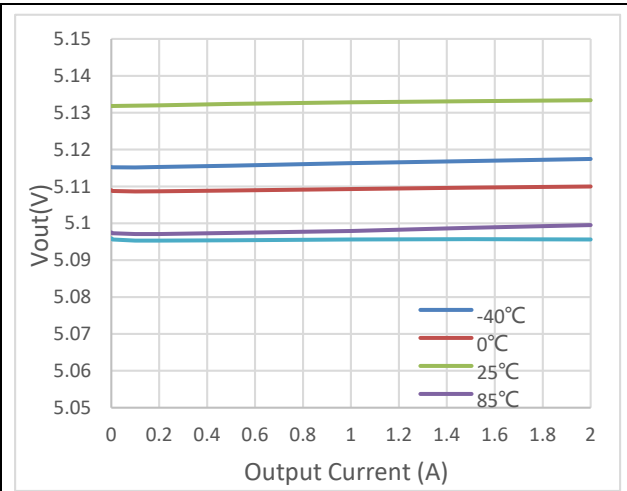

$V_{OUT}=5.1\text{V}$

Output Voltage vs Output Current

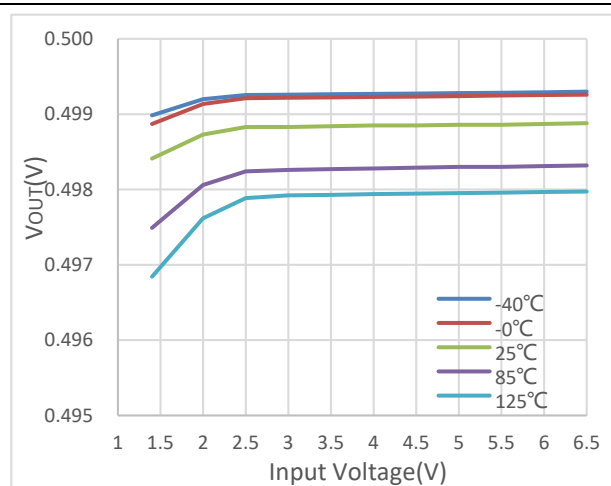

$V_{IN}=1.4\text{V}$, $V_{OUT}=0.5\text{V}$, $OUT=FB$

Output Voltage vs Input Voltage

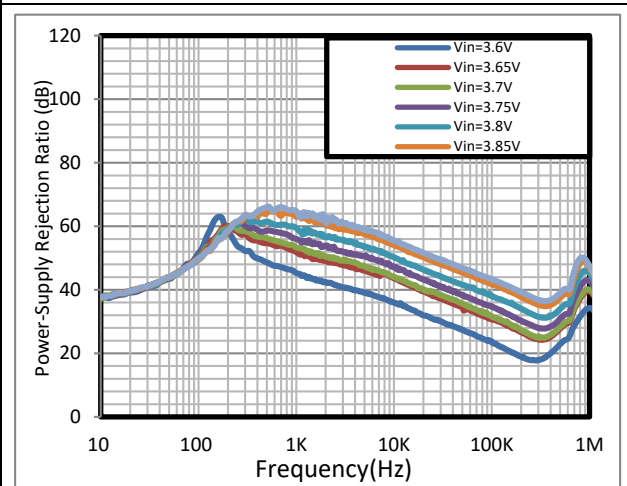

$V_{OUT} = 3.3\text{V}$, $I_{OUT} = 2\text{A}$

$C_{OUT} = 10\ \mu\text{F} \parallel 10\ \mu\text{F}$, $C_{FF} = 10\ \text{nF}$

PSRR vs Frequency and Vin for Vout = 3.3V

Typical Operating Characteristics

$T_A = 25^\circ\text{C}$, $V_{IN} = 1.4\text{ V}$ or $V_{IN} = V_{OUT(\text{TARGET})} + 0.4\text{ V}$ (whichever is greater), $V_{OUT(\text{TARGET})} = 0.5\text{ V}$, $V_{EN} = 1.1\text{ V}$, $C_{IN} = 10\ \mu\text{F}$, $C_{OUT} = 10\ \mu\text{F}$, unless otherwise noted.

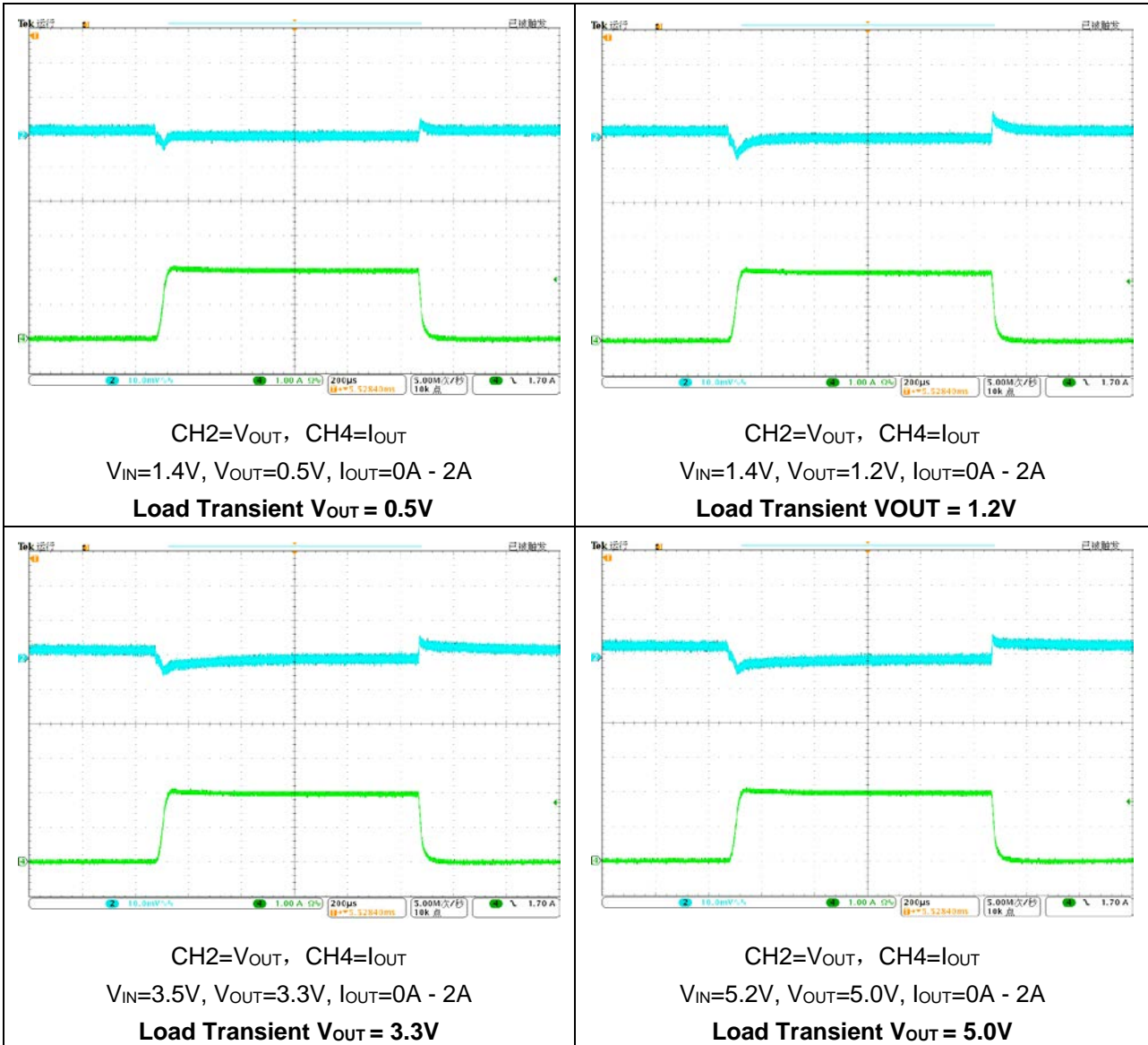

Typical Operating Characteristics

$T_A = 25^\circ\text{C}$, $V_{IN} = 1.4\text{ V}$ or $V_{IN} = V_{OUT(\text{TARGET})} + 0.4\text{ V}$ (whichever is greater), $V_{OUT(\text{TARGET})} = 0.5\text{ V}$, $V_{EN} = 1.1\text{ V}$, $C_{IN} = 10\ \mu\text{F}$, $C_{OUT} = 10\ \mu\text{F}$, unless otherwise noted.

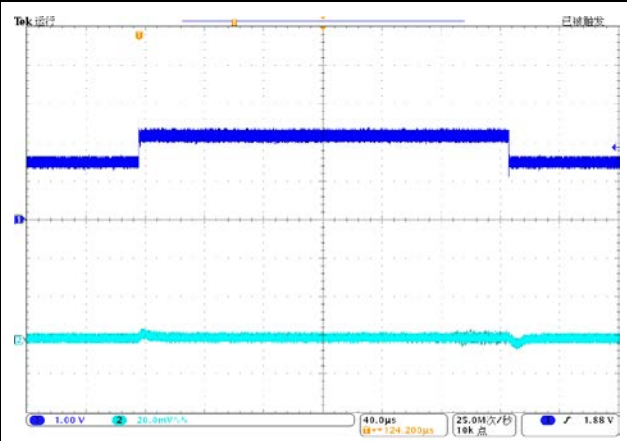

CH1= V_{IN} , CH2= V_{OUT}
 $V_{IN}=1.4 - 2.0\text{V}$, $V_{OUT}=0.5\text{V}$, $I_{OUT}=5\text{mA}$
Line Regulation @ $V_{OUT}=0.5\text{V}$

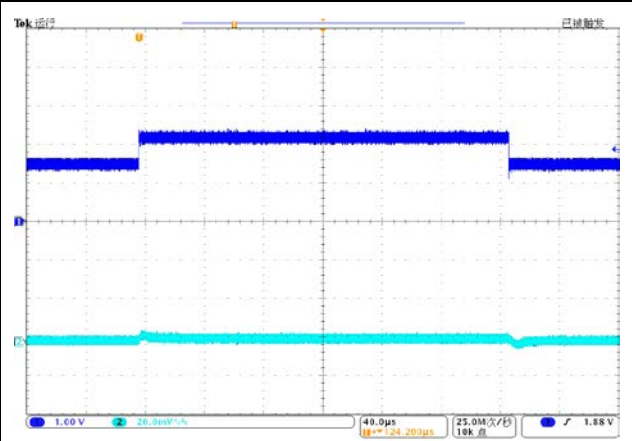

CH1= V_{IN} , CH2= V_{OUT}
 $V_{IN}=1.4 - 2.0\text{V}$, $V_{OUT}=1.2\text{V}$, $I_{OUT}=5\text{mA}$
Line Regulation @ $V_{OUT}=1.2\text{V}$

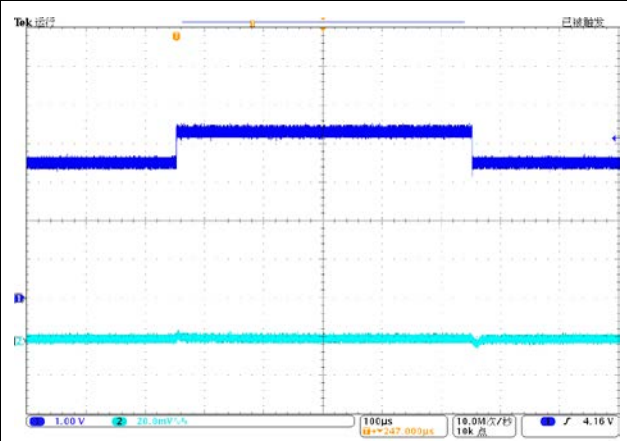

CH1= V_{IN} , CH2= V_{OUT}
 $V_{IN}=2.0 - 3.5\text{V}$, $V_{OUT}=3.3\text{V}$, $I_{OUT}=5\text{mA}$
Line Regulation @ $V_{OUT}=3.3\text{V}$

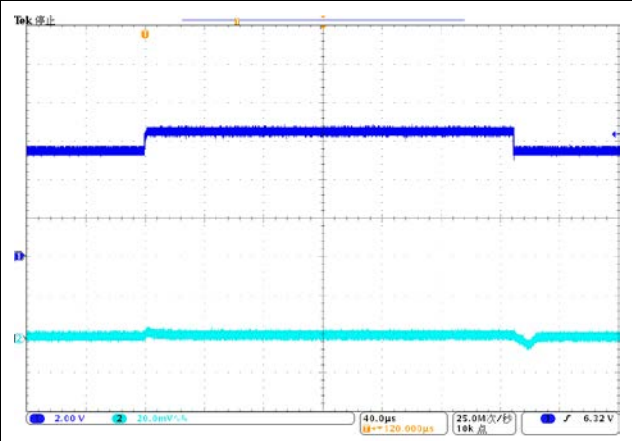

CH1= V_{IN} , CH2= V_{OUT}
 $V_{IN}=5.2 - 6.5\text{V}$, $V_{OUT}=5.0\text{V}$, $I_{OUT}=5\text{mA}$
Line Regulation @ $V_{OUT}=5.0\text{V}$

Typical Operating Characteristics

$T_A = 25^\circ\text{C}$, $V_{IN} = 1.4\text{ V}$ or $V_{IN} = V_{OUT(\text{TARGET})} + 0.4\text{ V}$ (whichever is greater), $V_{OUT(\text{TARGET})} = 0.5\text{ V}$, $V_{EN} = 1.1\text{ V}$, $C_{IN} = 10\ \mu\text{F}$, $C_{OUT} = 10\ \mu\text{F}$, unless otherwise noted.

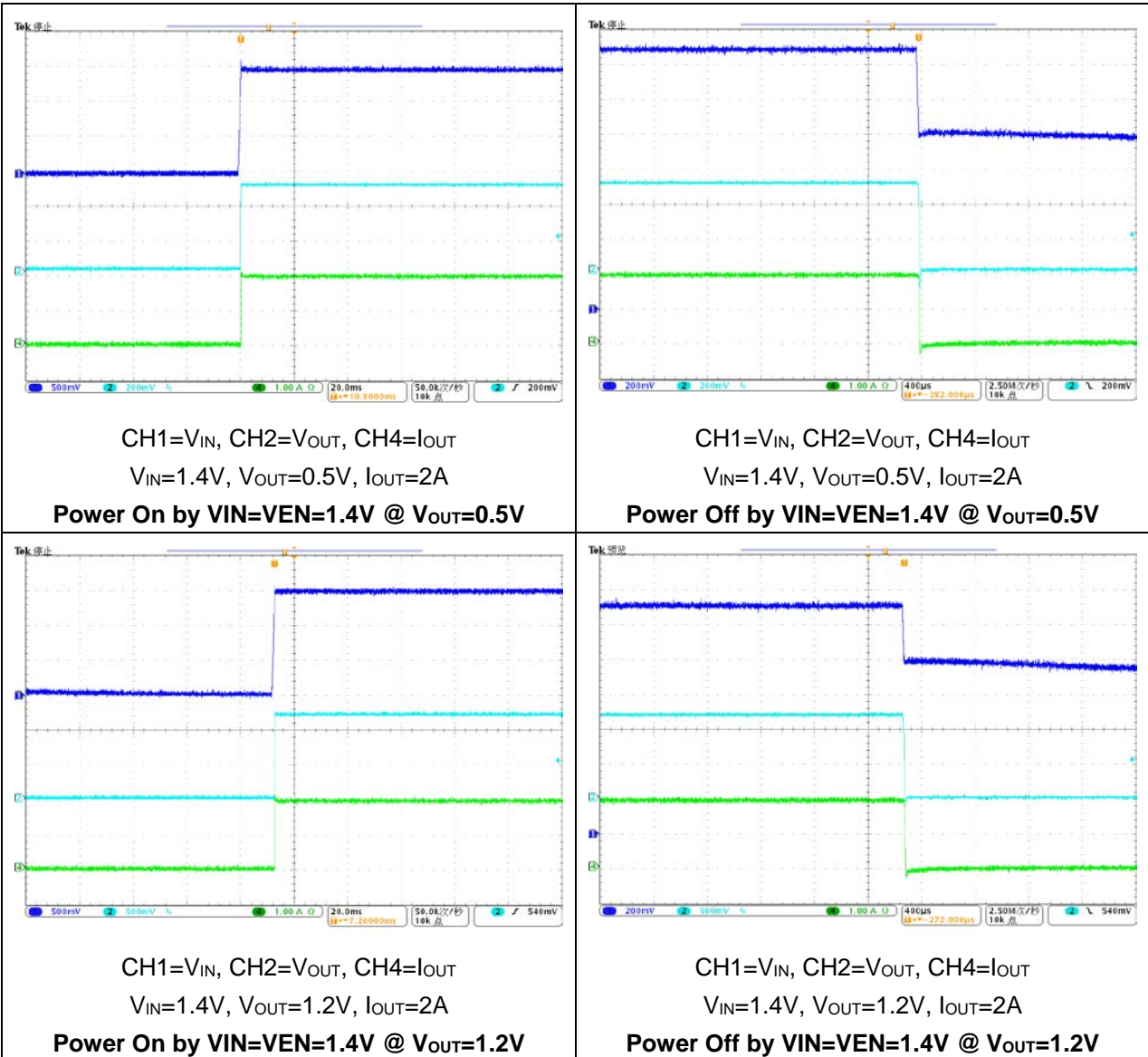

Typical Operating Characteristics

$T_A = 25^\circ\text{C}$, $V_{IN} = 1.4\text{ V}$ or $V_{IN} = V_{OUT(\text{TARGET})} + 0.4\text{ V}$ (whichever is greater), $V_{OUT(\text{TARGET})} = 0.5\text{ V}$, $V_{EN} = 1.1\text{ V}$, $C_{IN} = 10\ \mu\text{F}$, $C_{OUT} = 10\ \mu\text{F}$, unless otherwise noted.

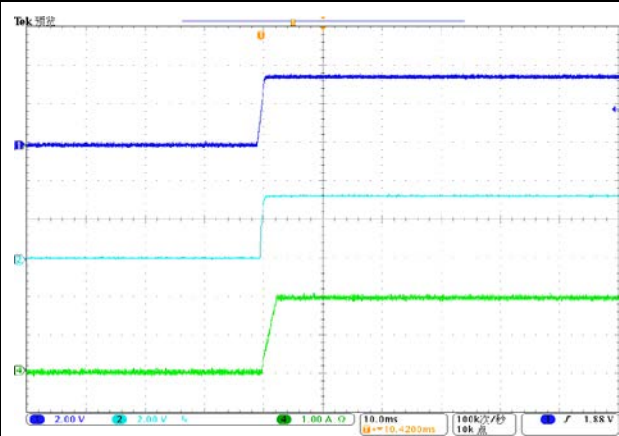

CH1= V_{IN} , CH2= V_{OUT} , CH4= I_{OUT}
 $V_{IN}=3.5\text{V}$, $V_{OUT}=3.3\text{V}$, $I_{OUT}=2\text{A}$
Power On by $V_{IN}=V_{EN}=3.5\text{V}$ @ $V_{OUT}=3.3\text{V}$

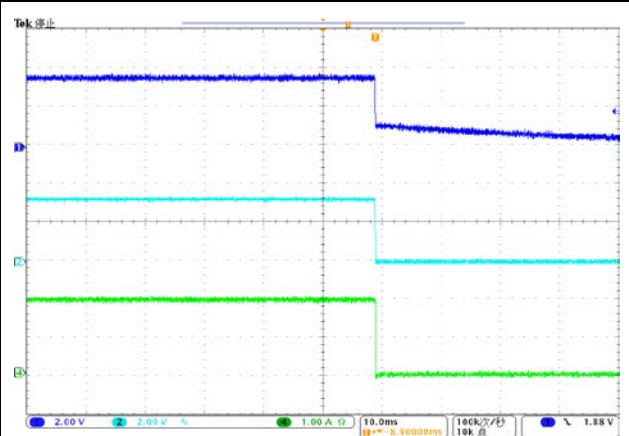

CH1= V_{IN} , CH2= V_{OUT} , CH4= I_{OUT}
 $V_{IN}=3.5\text{V}$, $V_{OUT}=3.3\text{V}$, $I_{OUT}=2\text{A}$
Power Off by $V_{IN}=V_{EN}=3.5\text{V}$ @ $V_{OUT}=3.3\text{V}$

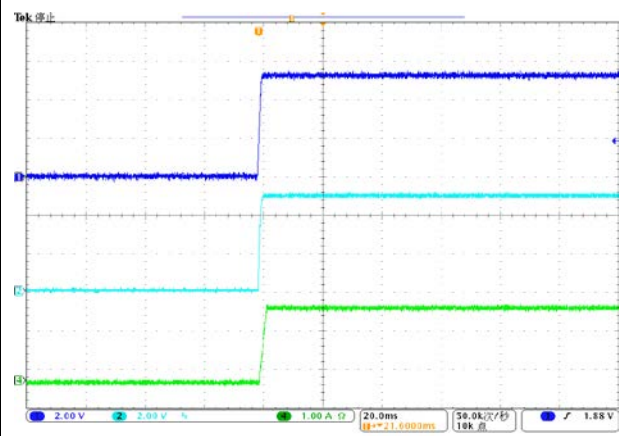

CH1= V_{IN} , CH2= V_{OUT} , CH4= I_{OUT}
 $V_{IN}=5.2\text{V}$, $V_{OUT}=5.0\text{V}$, $I_{OUT}=2\text{A}$
Power On by $V_{IN}=V_{EN}=5.2\text{V}$ @ $V_{OUT}=5.0\text{V}$

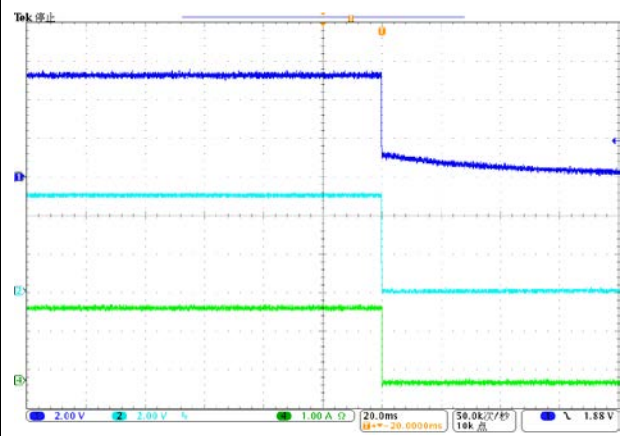

CH1= V_{IN} , CH2= V_{OUT} , CH4= I_{OUT}
 $V_{IN}=5.2\text{V}$, $V_{OUT}=5.0\text{V}$, $I_{OUT}=2\text{A}$
Power Off by $V_{IN}=V_{EN}=5.2\text{V}$ @ $V_{OUT}=5.0\text{V}$

Typical Operating Characteristics

$T_A = 25^\circ\text{C}$, $V_{IN} = 1.4\text{ V}$ or $V_{IN} = V_{OUT(\text{TARGET})} + 0.4\text{ V}$ (whichever is greater), $V_{OUT(\text{TARGET})} = 0.5\text{ V}$, $V_{EN} = 1.1\text{ V}$, $C_{IN} = 10\ \mu\text{F}$, $C_{OUT} = 10\ \mu\text{F}$, unless otherwise noted.

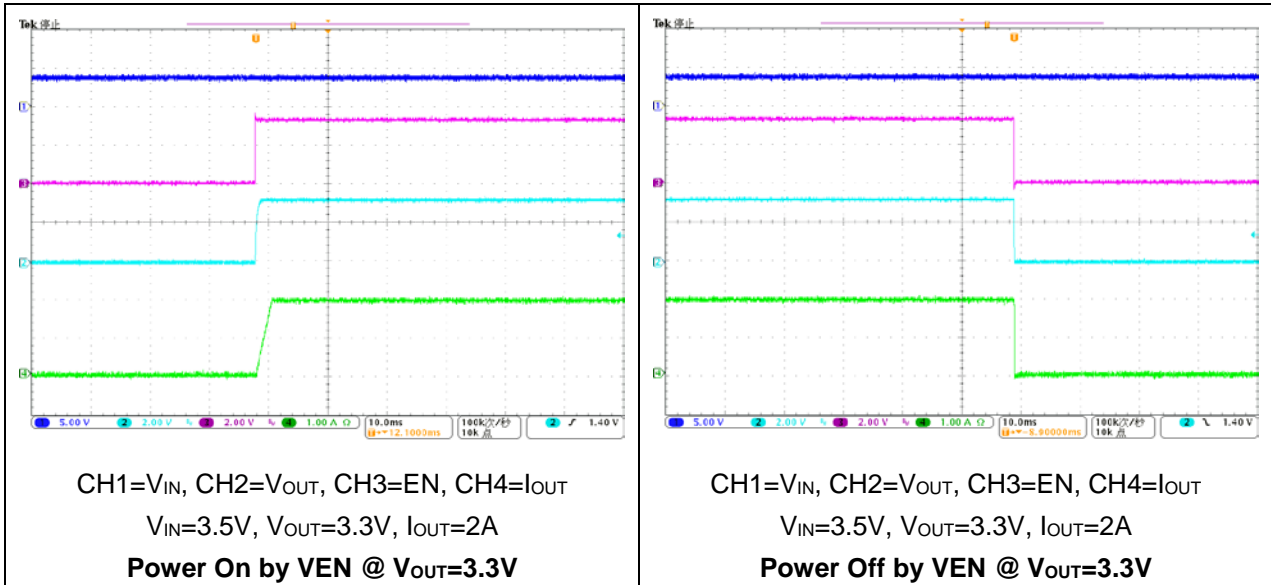

7 Typical application circuit

Figure 7-1 Typical GD30LD1000x application circuit with adjustable resistance

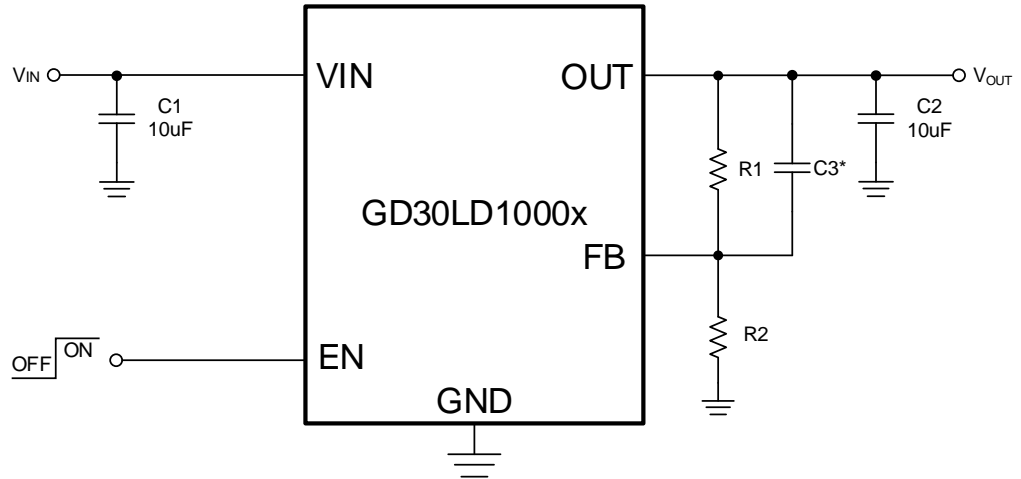

Table 7-1 Adjusted V_{OUT} by external feedback resistor

$V_{OUT}(V)$	External Feedback Resistor	
	R1 (k Ω)	R2(k Ω)
0.5	0	NC
0.6	11	54.9
0.7	10.2	25.5
0.8	10.7	17.8
0.9	11	13.7
1.0	11	11
1.2	9.31	6.65
1.8	10.2	3.92
2.5	10.8	2.7
3.0	11	2.2
3.3	11.2	2
5.0	10.8	1.2
5.2	12.22	1.3

8 Layout guideline

Figure 8-1 Typical GD30LD1000x(SOP8) layout guideline

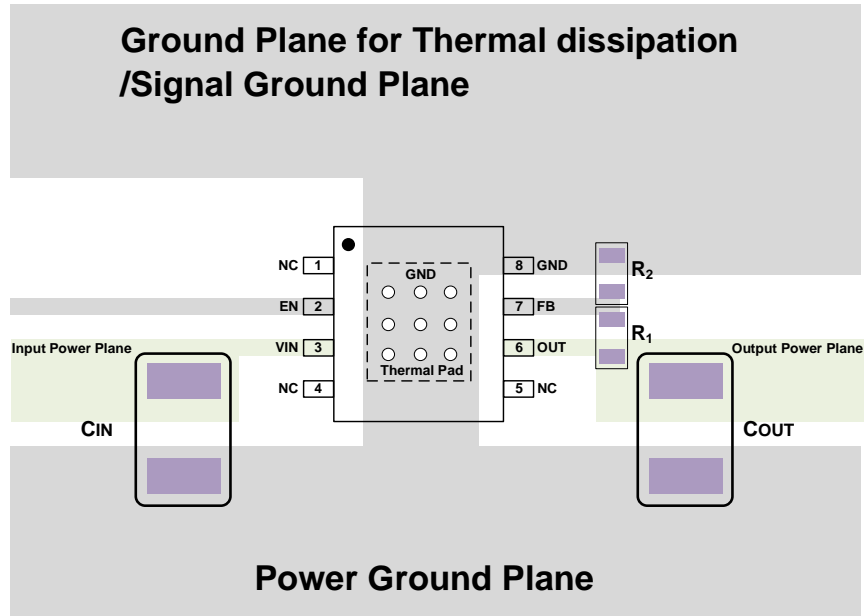
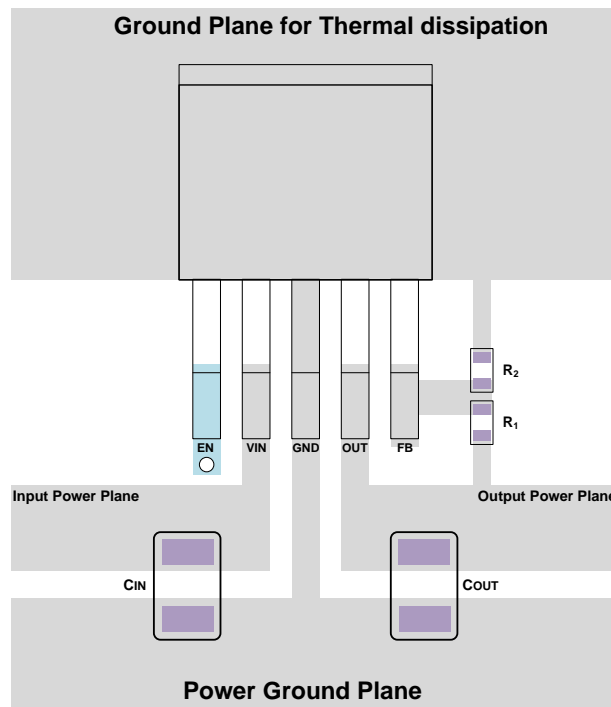

Figure 8-2 Typical GD30LD1000x(TO263) layout guideline



Notes:

1. The capacitor C_{IN} and C_{OUT} should be placed on the top layer to reduce parasitic parameters.
2. All capacitors are as close as possible to the corresponding pins of the LDO regulator's.

9 Package information

9.1 SOP8 package outline dimensions

Figure 9-1 SOP8 package outline

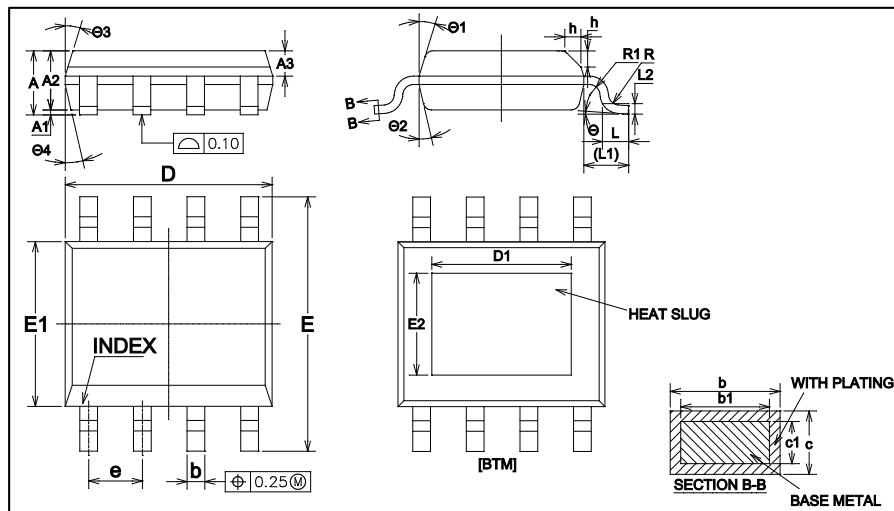

Table 9-1 SOP8 package dimensions(in mm)

Symbol	Min	Typ	Max
A	1.35	1.55	1.70
A1	0	0.05	0.10
A2	1.25	1.40	1.60
A3	0.50	0.60	0.70
b	0.36	—	0.51
b1	0.36	0.41	0.46
c	0.17	—	0.25
c1	0.17	0.20	0.23
D	4.80	4.90	5.00
D1	3.10	3.30	3.50
E	5.80	6.00	6.20
E1	3.80	3.90	4.00
E2	2.20	2.40	2.60
e	1.17	1.27	1.37
L	0.45	0.60	0.80
L1	—	1.04	—
L2	—	0.25	—
R	0.07	—	—
R1	0.07	—	—
h	0.30	0.40	0.50

Symbol	Min	Typ	Max
θ	0°	—	8°
$\theta 1$	15°	17°	19°
$\theta 2$	11°	13°	15°
$\theta 3$	15°	17°	19°
$\theta 4$	11°	13°	15°

(Original dimensions are in millimeters)

Figure 9-2 SOP8 recommend Footprint

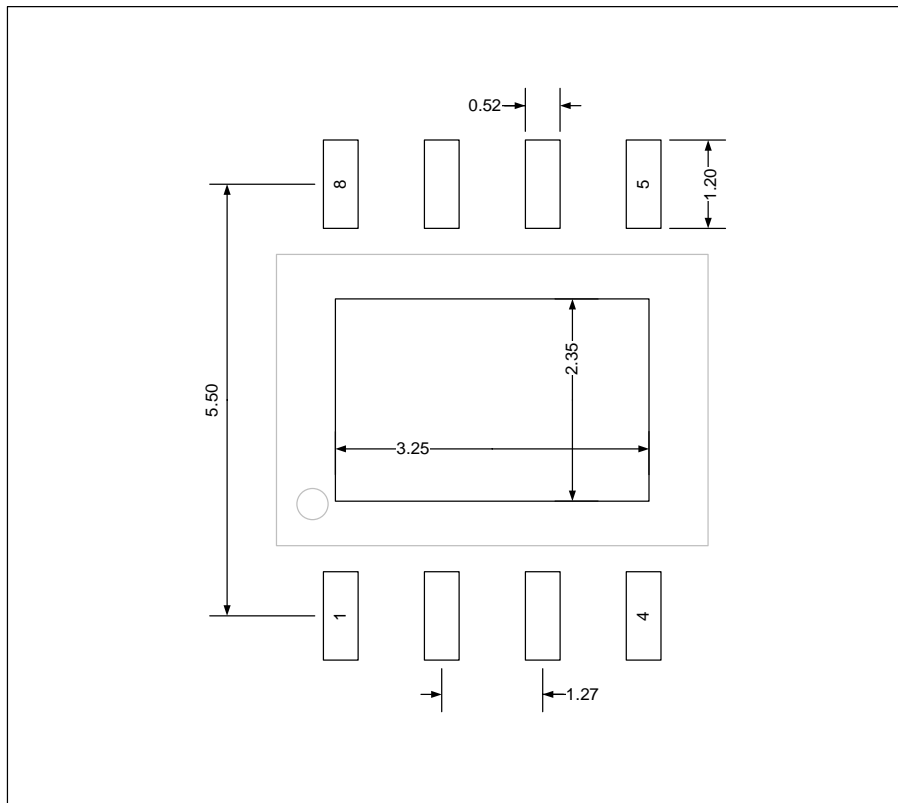

(Original dimensions are in millimeters)

9.2 TO263 package outline dimensions

Figure 9-3 TO263 package outline

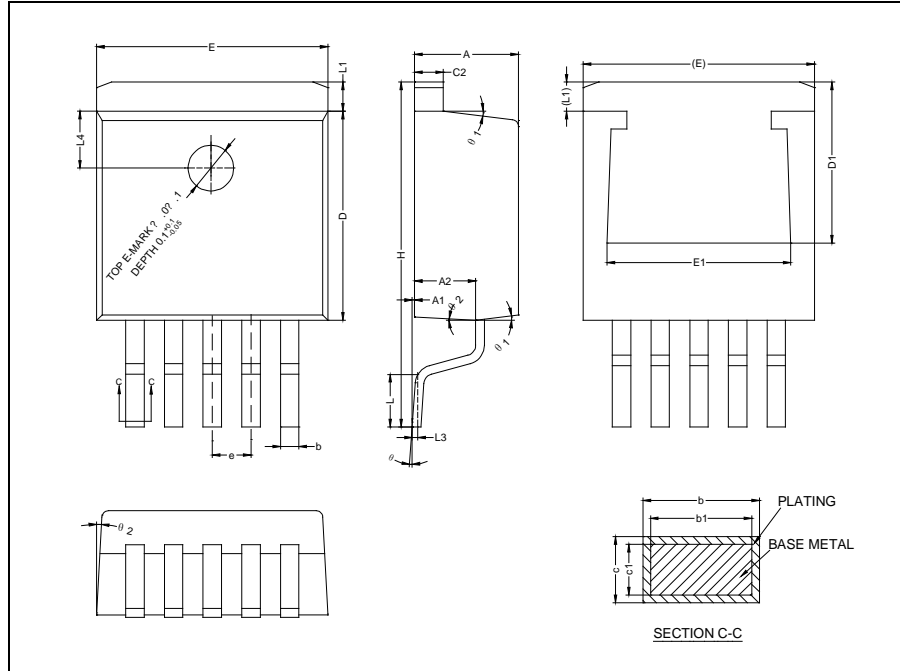

Table 9-2 TO263 package dimensions(in mm)

Symbol	Min	Typ	Max
A	4.40	4.57	4.70
A1	0	0.10	0.25
A2	2.59	2.69	2.79
b	0.77	—	0.90
b1	0.76	0.81	0.86
c	0.34	—	0.47
c1	0.33	0.38	0.43
c2	1.22	—	1.32
D	9.05	9.15	9.25
D1	6.86	—	7.50
E	10.06	10.16	10.26
E1	7.50	—	8.30
e	—	1.70	—
H	14.70	15.10	15.50
L	2.00	2.30	2.60
L1	1.17	1.27	1.40
L3	—	0.25	—
L4	—	2.50	—
θ	0°	—	8°

Symbol	Min	Typ	Max
$\theta 1$	5°	7°	9°
$\theta 2$	1°	3°	5°
A	4.40	4.57	4.70
A1	0	0.10	0.25
A2	2.59	2.69	2.79
b	0.77	—	0.90

(Original dimensions are in millimeters)

Figure 9-4 TO263 recommend Footprint

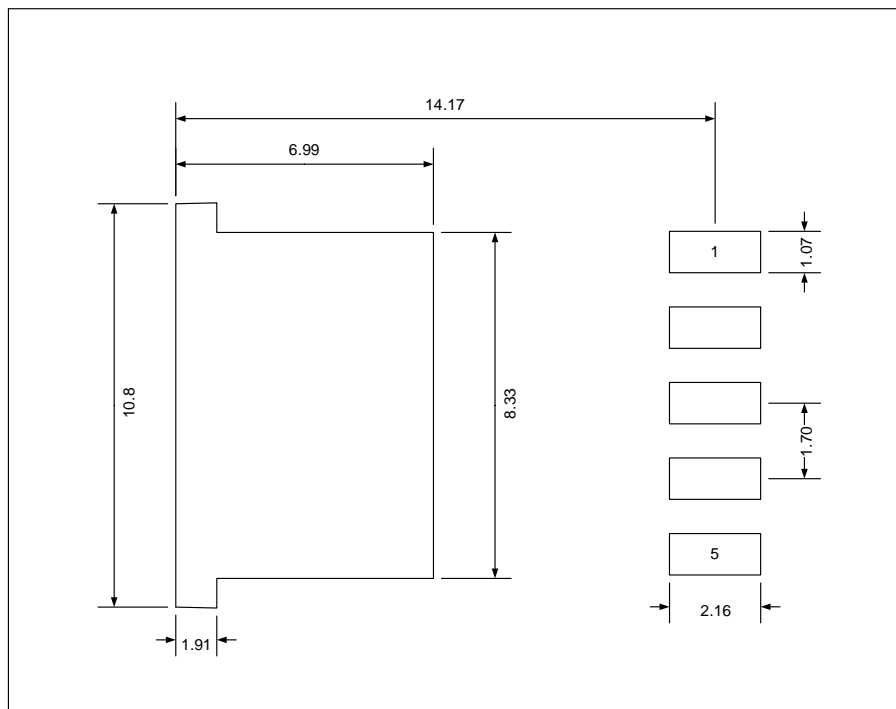

9.3 Thermal characteristics

Thermal resistance is used to characterize the thermal performance of the package device, which is represented by the Greek letter “ Θ ”. For semiconductor devices, thermal resistance represents the steady-state temperature rise of the chip junction due to the heat dissipated on the chip surface.

Θ_{JA} : Thermal resistance, junction-to-ambient.

Θ_{JB} : Thermal resistance, junction-to-board.

Θ_{JC} : Thermal resistance, junction-to-case.

Ψ_{JB} : Thermal characterization parameter, junction-to-board.

Ψ_{JT} : Thermal characterization parameter, junction-to-top center.

$$\Theta_{JA} = (T_J - T_A)/P_D$$

$$\Theta_{JB} = (T_J - T_B)/P_D$$

$$\Theta_{JC} = (T_J - T_C)/P_D$$

Where, T_J = Junction temperature.

T_A = Ambient temperature

T_B = Board temperature

T_C = Case temperature which is monitoring on package surface

P_D = Total power dissipation

Θ_{JA} represents the resistance of the heat flows from the heating junction to ambient air. It is an indicator of package heat dissipation capability. Lower Θ_{JA} can be considerate as better overall thermal performance. Θ_{JA} is generally used to estimate junction temperature.

Θ_{JB} is used to measure the heat flow resistance between the chip surface and the PCB board.

Θ_{JC} represents the thermal resistance between the chip surface and the package top case.

Θ_{JC} is mainly used to estimate the heat dissipation of the system (using heat sink or other heat dissipation methods outside the device package).

Table 9-3 SOP8 Package thermal characteristics⁽¹⁾

Symbol	Condition	Package	Value	Unit
Θ_{JA}	Natural convection, 2S2P PCB	SOP8	43.5	°C/W
Θ_{JB}	Cold plate, 2S2P PCB	SOP8	13.7	°C/W
Θ_{JC}	Cold plate, 2S2P PCB	SOP8	28.6	°C/W
Ψ_{JB}	Natural convection, 2S2P PCB	SOP8	13.6	°C/W
Ψ_{JT}	Natural convection, 2S2P PCB	SOP8	4.71	°C/W

Table 9-4 TO263 Package thermal characteristics⁽¹⁾

Symbol	Condition	Package	Value	Unit
Θ_{JA}	Natural convection, 2S2P PCB	TO263	TBD	°C/W
Θ_{JB}	Cold plate, 2S2P PCB	TO263	TBD	°C/W
Θ_{JC}	Cold plate, 2S2P PCB	TO263	TBD	°C/W
Ψ_{JB}	Natural convection, 2S2P PCB	TO263	TBD	°C/W
Ψ_{JT}	Natural convection, 2S2P PCB	TO263	TBD	°C/W

(1) Thermal characteristics are based on simulation, and meet JEDEC specification.

10 Ordering information

Table 10-1 Part ordering code for GD30LD1000x devices

Ordering Code	Package	Package Type	Packing Type	MOQ	Temperature Junction Range
GD30LD1000WGTR-I	SOP8	Green	Tape&Reel	4000	Industrial -40°C to +125°C
GD30LD1000NBTR-I	TO263	Green	Tape&Reel	3000	Industrial -40°C to +125°C

11 Revision history

Table 11-1 Revision history

Revision No.	Description	Date
1.0	Initial Release	May.29, 2023

Important Notice

This document is the property of GigaDevice Semiconductor Inc. and its subsidiaries (the "Company"). This document, including any product of the Company described in this document (the "Product"), is owned by the Company according to the laws of the People's Republic of China and other applicable laws. The Company reserves all rights under such laws and no Intellectual Property Rights are transferred (either wholly or partially) or licensed by the Company (either expressly or impliedly) herein. The names and brands of third party referred thereto (if any) are the property of their respective owner and referred to for identification purposes only.

The Company makes no representations or warranties of any kind, express or implied, with regard to the merchantability and the fitness for a particular purpose of the Product, nor does the Company assume any liability arising out of the application or use of any Product described in this document. Any information provided in this document is provided only for reference purposes. It is the sole responsibility of the user of this document to determine whether the Product is suitable and fit for its applications and products planned, and properly design, program, and test the functionality and safety of its applications and products planned using the Product. Unless otherwise expressly specified in the datasheet of the Product, the Product is designed, developed, and/or manufactured for ordinary business, industrial, personal, and/or household applications only, and the Product is not designed or intended for use in (i) safety critical applications such as weapons systems, nuclear facilities, atomic energy controller, combustion controller, aeronautic or aerospace applications, traffic signal instruments, pollution control or hazardous substance management; (ii) life-support systems, other medical equipment or systems (including life support equipment and surgical implants); (iii) automotive applications or environments, including but not limited to applications for active and passive safety of automobiles (regardless of front market or aftermarket), for example, EPS, braking, ADAS (camera/fusion), EMS, TCU, BMS, BSG, TPMS, Airbag, Suspension, DMS, ICMS, Domain, ESC, DCDC, e-clutch, advanced-lighting, etc.. Automobile herein means a vehicle propelled by a self-contained motor, engine or the like, such as, without limitation, cars, trucks, motorcycles, electric cars, and other transportation devices; and/or (iv) other uses where the failure of the device or the Product can reasonably be expected to result in personal injury, death, or severe property or environmental damage (collectively "Unintended Uses"). Customers shall take any and all actions to ensure the Product meets the applicable laws and regulations. The Company is not liable for, in whole or in part, and customers shall hereby release the Company as well as its suppliers and/or distributors from, any claim, damage, or other liability arising from or related to all Unintended Uses of the Product. Customers shall indemnify and hold the Company, and its officers, employees, subsidiaries, affiliates as well as its suppliers and/or distributors harmless from and against all claims, costs, damages, and other liabilities, including claims for personal injury or death, arising from or related to any Unintended Uses of the Product.

Information in this document is provided solely in connection with the Product. The Company reserves the right to make changes, corrections, modifications or improvements to this document and the Product described herein at any time without notice. The Company shall have no responsibility whatsoever for conflicts or incompatibilities arising from future changes to them. Information in this document supersedes and replaces information previously supplied in any prior versions of this document.

单击下面可查看定价，库存，交付和生命周期等信息

[>>GigaDevice\(兆易创新\)](#)