



BCT2186 1A, Low Dropout, Linear Regulators

BCT2186 1A Low Dropout Linear Regulators

GENERAL DESCRIPTION

The BCT2186 series low-power, low-noise, low-dropout, CMOS linear voltage regulators operate from a 1.8V to 5.5V input voltage. They are the perfect choice for low voltage, low power applications. A low ground current makes this part attractive for battery operated power systems. The BCT2186 series also offer ultra-low dropout voltage to prolong battery life in portable electronics. Output current minimum limit is 1A, and over-current protection limit is set at 1.4A typical.

These devices feature a shutdown function and are offered in active low with auto discharge. The output voltage is preset to voltages in the range of 0.8V to 5.0V. Other features include a low shutdown current, fold-back current limit and thermal shutdown protection.

The BCT2186 is available in Green DFN1.6x1.2-8L packages. It operates over an ambient temperature range of -40°C to +85°C.

FEATURES

- Wide Input Voltage Range: 1.8V to 5.5V
- Fixed Outputs of 0.8V, 0.9V, 1.0V, 1.05V, 1.1V, 1.2V, 1.3V, 1.35V, 1.5V, 1.8V, 2.2V, 2.5V, 2.8V, 3.0V, 3.3V and 3.6V
- Adjustable Output from 0.8V to 5.0V
- 1A Current Rating
- Low Dropout Voltage
- Output Current Limit
- Quick output discharge
- Thermal-Overload Protection
- High PSRR(75dB at 1kHz)
- -40°C to 85°C Operating Temperature Range
- Available in Green DFN1.6x1.2-8L Packages

APPLICATIONS

Cellular Telephones
Cordless Telephones
PCMCIA Cards
Modems
MP3 Player
Hand-Held Instruments
Portable/Battery-Powered Equipment



BCT2186 1A, Low Dropout, Linear Regulators

ORDERING INFORMATION

Order Number	V _{OUT} (V)	Package Type	Temperature Range	Marking	QTY/Reel
BCT2186ELA08-TR	0.8	DFN1.6x1.2-8L	-40°C to +85°C	M8X	4000
BCT2186ELA09-TR	0.9	DFN1.6x1.2-8L	-40°C to +85°C	M9X	4000
BCT2186ELA10-TR	1.0	DFN1.6x1.2-8L	-40°C to +85°C	M0X	4000
BCT2186ELA1A-TR	1.05	DFN1.6x1.2-8L	-40°C to +85°C	MAX	4000
BCT2186ELA11-TR	1.1	DFN1.6x1.2-8L	-40°C to +85°C	M1X	4000
BCT2186ELA12-TR	1.2	DFN1.6x1.2-8L	-40°C to +85°C	M2X	4000
BCT2186ELA13-TR	1.3	DFN1.6x1.2-8L	-40°C to +85°C	M3X	4000
BCT2186ELA1B-TR	1.35	DFN1.6x1.2-8L	-40°C to +85°C	MBX	4000
BCT2186ELA15-TR	1.5	DFN1.6x1.2-8L	-40°C to +85°C	M5X	4000
BCT2186ELA18-TR	1.8	DFN1.6x1.2-8L	-40°C to +85°C	M8X	4000
BCT2186ELA22-TR	2.2	DFN1.6x1.2-8L	-40°C to +85°C	M2X	4000
BCT2186ELA25-TR	2.5	DFN1.6x1.2-8L	-40°C to +85°C	M5X	4000
BCT2186ELA28-TR	2.8	DFN1.6x1.2-8L	-40°C to +85°C	M8X	4000
BCT2186ELA30-TR	3.0	DFN1.6x1.2-8L	-40°C to +85°C	M0X	4000
BCT2186ELA33-TR	3.3	DFN1.6x1.2-8L	-40°C to +85°C	M3X	4000
BCT2186ELA36-TR	3.6	DFN1.6x1.2-8L	-40°C to +85°C	M6X	4000
BCT2186ELAAJ-TR	ADJ	DFN1.6x1.2-8L	-40°C to +85°C	MJX	4000

Note:

"X" in Marking will be appeared as the batch code.

PIN CONFIGURATION

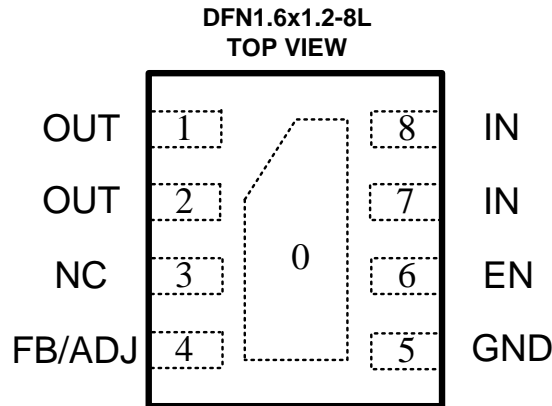

PIN DESCRIPTION

PIN		NAME	FUNCTION
V _{xx}	ADJ		
1	1	OUT	Regulator Output.
2	2	OUT	Regulator Output.
3	3	NC	Not connected.
4		FB	Feedback
	4	ADJ	Adjustable Voltage Version Only. This is used to set the output voltage of the device.
5	5	GND	Ground
6	6	EN	Enable pin, active high.
7	7	IN	Regulator Input.
8	8	IN	Regulator Input.
0	0	GND	Ground, Thermal pin.



BCT2186 1A, Low Dropout, Linear Regulators

ABSOLUTE MAXIMUM RATINGS

IN to GND.....	-0.3V to 6.5V
EN to GND.....	-0.3V to V_{IN}
OUT to GND.....	-0.3V to ($V_{IN}+0.3V$)
Output Short-Circuit Duration.....	Infinite
Power Dissipation, $P_D@T_A=25^\circ C$	
DFN1.6x1.2-8L.....	1.13W
Package Thermal Resistance	
DFN1.6x1.2-8L, θ_{JA}	110°C/W
Junction Temperature.....	150°C
Operating Temperature Range.....	-40°C to +85°C
Storage Temperature Range.....	-65°C to 150°C
Lead Temperature (Soldering, 10 sec).....	260°C
ESD Susceptibility HBM.....	4000V

NOTE:

Stresses beyond those listed under "Absolute Maximum Ratings" may cause permanent damage to the device. These are stress ratings only, and functional operation of the device at these or any other conditions beyond those indicated in the operational sections of the specifications is not implied. Exposure to absolute maximum rating conditions for extended periods may affect device reliability.

CAUTION

This integrated circuit can be damaged by ESD if you don't pay attention to ESD protection. Broadchip recommends that all integrated circuits be handled with appropriate precautions. Failure to observe proper handling and installation procedures can cause damage. ESD damage can range from subtle performance degradation to complete device failure. Precision integrated circuits may be more susceptible to damage because very small parametric changes could cause the device not to meet its published specifications.

Broadchip reserves the right to make any change in circuit design, specification or other related things if necessary without notice at any time. Please contact Broadchip sales office to get the latest datasheet.

ELECTRICAL CHARACTERISTICS

($V_{IN} = V_{OUT(NOMINAL)} + 0.5V^{(1)}$, $T_A = -40^{\circ}C$ to $+85^{\circ}C$, unless otherwise specified.)

PARAMETER	SYM	CONDITIONS	MIN	TYP	MAX	UNITS
Input Voltage	V_{IN}		1.8		5.5	V
Output Voltage Accuracy ⁽¹⁾		$I_{OUT} = 1mA$	-1.0		1.0	%
Maximum Output Current ⁽¹⁾		$V_{IN} = 1.8V$ or $(V_{OUT} + 0.5V)$	1			A
Current Limit ⁽¹⁾	I_{LIM}	$V_{IN} = 1.8V$ or $(V_{OUT} + 0.5V)$		1.4		A
Short-Circuit Current ⁽¹⁾	I_{SHORT}	$V_{IN} = 1.8V$ or $(V_{OUT} + 0.5V)$		0.6		A
Ground Pin Current	I_Q	No load, $EN = 2V$		30		μA
Dropout Voltage ⁽²⁾		$I_{OUT} = 1A$	$V_{OUT} = 1.2V$	0.60		V
			$V_{OUT} = 1.5V$	0.30		
			$V_{OUT} = 1.8V$	0.18		
			$V_{OUT} = 2.5V$	0.12		
			$V_{OUT} = 2.8V$	0.11		
			$V_{OUT} = 3.3V$	0.10		
			$V_{OUT} = 3.6V$	0.09		
Line Regulation ⁽¹⁾	ΔV_{LNR}	$V_{IN} = 1.8V$ or $(V_{OUT} + 0.5V)$ to $5.5V$, $I_{OUT} = 1mA$		0.05		%/V
Load Regulation	ΔV_{LDR}	$I_{OUT} = 1mA$ to $1A$, $C_{OUT} = 1\mu F$, $V_{OUT} > 2V$		0.002		%mA
		$I_{OUT} = 1mA$ to $1A$, $C_{OUT} = 1\mu F$, $V_{OUT} \leq 2V$		0.004		
Power Supply Rejection Ratio	PSRR	$I_{LOAD} = 50mA$, $C_{OUT} = 1\mu F$, $f = 1kHz$, $V_{IN} = V_{OUT} + 1V$		75		dB
SHUTDOWN⁽³⁾						
EN Input Threshold	V_{IH}	$V_{IN} = 1.8V$ to $5.5V$,	1.5			V
	V_{IL}	$V_{EN} = -0.3V$ to V_{IN}			0.3	
EN Input Bias Current	I_{IN}	$EN = 5.5V$		1.5		μA
		$EN = 0V$		0.01		μA
Shutdown Supply Current	$I_{Q(SHDN)}$	$EN = 0.4V$		0.01	1	μA
Shutdown Exit Delay ⁽⁴⁾		$C_{OUT} = 1\mu F$, No Load		30		μs
THERMAL PROTECTION						
Thermal Shutdown Temperature	T_{SHDN}			150		$^{\circ}C$
Thermal Shutdown Hysteresis	ΔT_{SHDN}			15		$^{\circ}C$

NOTES:

1. $V_{IN} = V_{OUT (NOMINAL)} + 0.5V$ or $2.5V$, whichever is greater.
2. The dropout voltage is defined as $V_{IN} - V_{OUT}$, when V_{OUT} is 100mV below the value of nominal V_{OUT} .
3. $V_{EN} = -0.3V$ to V_{IN}
4. Time needed for V_{OUT} to reach 90% of final value.

TYPICAL APPLICATION CIRCUIT

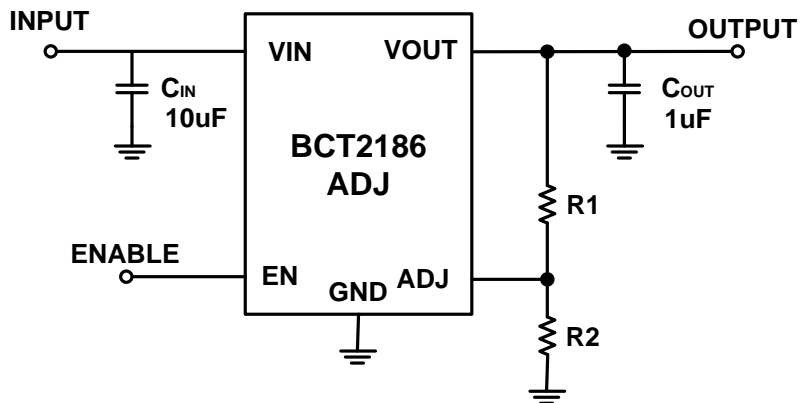
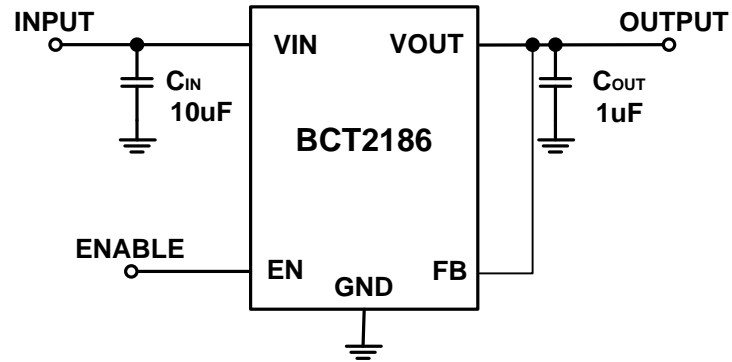

NOTE: $V_{OUT} = (R1 + R2) / R2 \times 0.8 V$

APPLICATION NOTE

Programming the BCT2186 Adjustable LDO regulator

The output voltage of the BCT2186 adjustable regulator is programmed using an external resistor divider as show in Figure as below. The output voltage is calculated using equation as below:

$$V_{OUT} = V_{REF} \times \left(1 + \frac{R1}{R2} \right)$$

Where:

$V_{REF}=0.8V$ typ (the internal reference voltage)

Resistors R1 and R2 should be chosen for approximately 50uA divider current. Lower value resistors can be used for improved noise performance, but the solution consumes more power. Higher resistor values should be avoided as leakage current into/out of ADJ across R1/R2 creates an offset voltage that artificially increases/decreases the feedback voltage and thus erroneously decrease/increases V_{OUT} .

Enable Function

The BCT2186 features an LDO regulator enable/disable function. To assure the LDO regulator will switch on; the EN turn on control level must be greater than 1.5 volts. The LDO regulator will go into the shutdown mode when the voltage on the EN pin falls below 0.3 volts. For to protect the system, the BCT2186 have a quick discharge function. If the enable function is not needed in a specific application, it may be tied to VIN to keep the LDO regulator in a continuously on state.

Thermal Considerations

Thermal protection limits power dissipation in BCT2186. When the operation junction temperature exceeds 150°C, the OTP circuit starts the thermal shutdown function turn the pass element off. The pass element turns on again after the junction temperature cools by 15°C.

For continue operation, do not exceed absolute maximum operation junction temperature 150°C. The power dissipation definition in device is:

$$P_D = (V_{IN} - V_{OUT}) \times I_{OUT} + V_{IN} \times I_Q$$

The maximum power dissipation depends on the thermal resistance of IC package, PCB layout, the rate of surroundings airflow and temperature difference between junction to ambient. The maximum power dissipation can be calculated by following formula:

$$P_D(\text{MAX}) = (T_J(\text{MAX}) - T_A) / \theta_{JA}$$

Where $T_J(\text{MAX})$ is the maximum operation junction temperature 150°C , T_A is the ambient temperature and the θ_{JA} is the junction to ambient thermal resistance. For recommended operating conditions specification of BCT2186, where $T_J(\text{MAX})$ is the maximum junction temperature of the die (150°C) and T_A is the maximum ambient temperature. The junction to ambient thermal resistance (θ_{JA} is layout dependent) for DFN1.6x1.2-8L package is 110°C/W , on standard JEDEC 51-3 thermal test board. The maximum power dissipation at $T_A = 25^\circ\text{C}$ can be calculated by following formula:

$$P_D(\text{MAX}) = (150^\circ\text{C} - 25^\circ\text{C}) / 110 = 1.14\text{W (DFN1.6x1.2-8L)}$$

The maximum power dissipation depends on operating ambient temperature for fixed $T_J(\text{MAX})$ and thermal resistance θ_{JA} . It is also useful to calculate the junction of temperature of the BCT2186 under a set of specific conditions. In this example let the Input voltage $V_{IN} = 3.3\text{V}$, the output current $I_O = 500\text{mA}$ and the case temperature $T_A = 40^\circ\text{C}$ measured by a thermal couple during operation. The power dissipation for the $V_O = 2.8\text{V}$ version of the BCT2186 can be calculated as:

$$P_D = (3.3\text{V} - 2.8\text{V}) \times 500\text{mA} + 3.3\text{V} \times 30\mu\text{A} \\ = 250.01\text{mW}$$

And the junction temperature, T_J , can be calculated as follows:

$$T_J = T_A + P_D \times \theta_{JA} = 40^\circ\text{C} + 0.25\text{W} \times 110^\circ\text{C/W} \\ = 40^\circ\text{C} + 27.5^\circ\text{C} = 67.5^\circ\text{C} < T_J(\text{MAX}) = 150^\circ\text{C}$$

For this operating condition, T_J is lower than the absolute maximum operating junction temperature, 150°C , so it is safe to use the BCT2186 in this configuration.

TAPE AND REEL INFORMATION

REEL DIMENSIONS

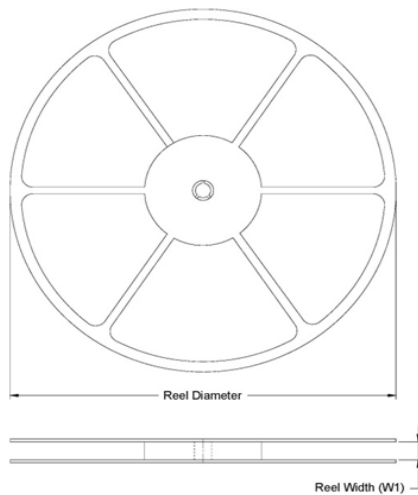

TAPE DIMENSIONS

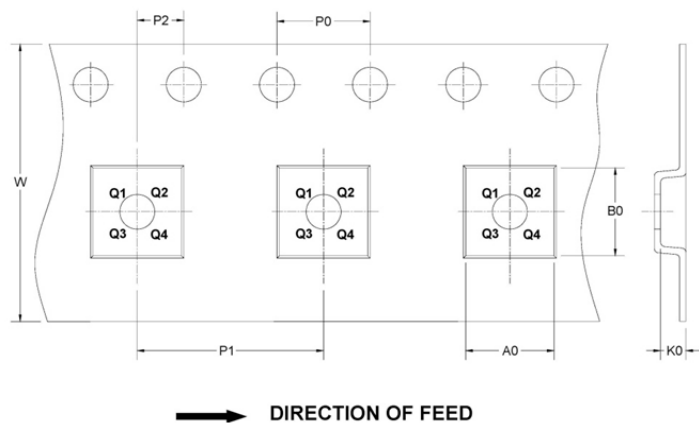

KEY PARAMETER LIST OF TAPE AND REEL

Device Name	Package Type	Reel Diameter	Unit: mm								Pin 1 Quadrant	Reel Q'ty
			Reel Width W1	A0	B0	K0	P0	P1	P2	W		
BCT2186ELAXX-TR	DFN1.6x1.2-8L	7"	9.5±1	1.4±0.05	1.85±0.05	0.5±0.05	4±0.1	4±0.1	2±0.05	8+0.3/-0.1	Q1	4000

PACKAGE OUTLINE DIMENSIONS

DFN1.6x1.2-8L

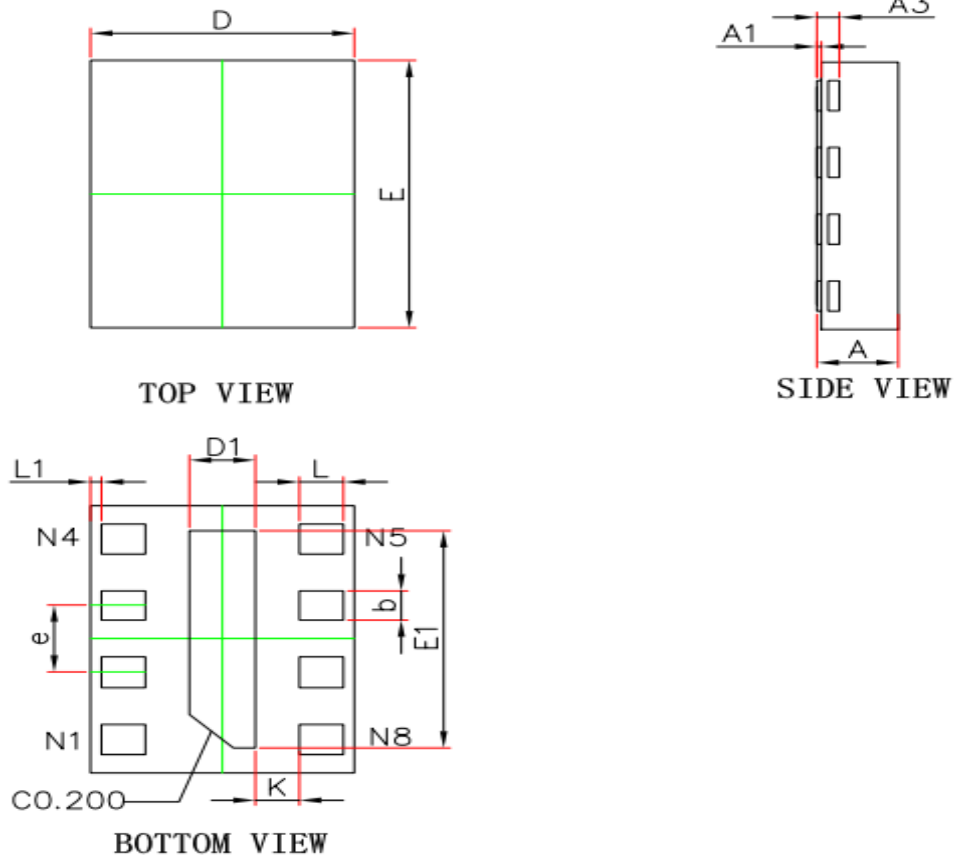

Symbol	Dimensions In Millimeters		Dimensions In Inches	
	Min.	Max.	Min.	Max.
A	0.320	0.400	0.013	0.016
A1	0.000	0.050	0.000	0.002
A3	0.102REF.		0.004REF.	
D	1.100	1.300	0.043	0.051
E	1.500	1.700	0.059	0.067
D1	0.200	0.400	0.008	0.016
E1	1.200	1.400	0.047	0.055
K	0.200REF.		0.008REF.	
b	0.130	0.230	0.005	0.009
e	0.400BSC.		0.016BSC.	
L	0.150	0.250	0.006	0.010
L1	0.050REF.		0.002REF.	

PCB Layout Pattern (Unit: mm)

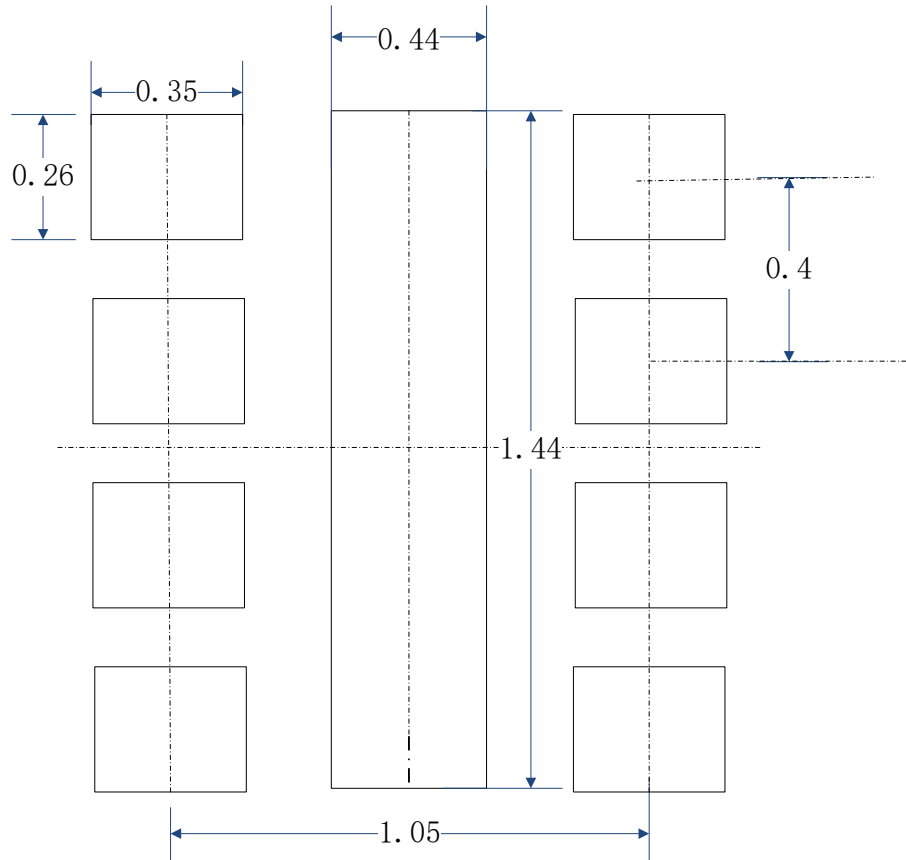

单击下面可查看定价，库存，交付和生命周期等信息

[>>Broadchip\(广芯电子\)](#)