

SMD1210 Series Surface Mount PPTC Devices

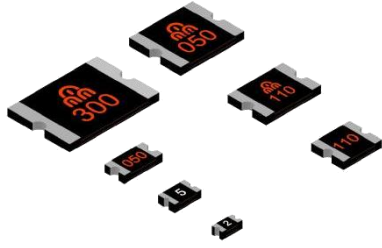

- | Features | Applications |
|---|---|
| <input type="checkbox"/> compact design saves board space | <input type="checkbox"/> USB port protection - USB 2.0, 3.0&OTG |
| <input type="checkbox"/> RoHS compliant and lead-free | <input type="checkbox"/> HDMI 1.4 Source protection |
| <input type="checkbox"/> Halogen-free | <input type="checkbox"/> PDAs / digital cameras |
| <input type="checkbox"/> Fast response to fault current | <input type="checkbox"/> Game console port protection |
| <input type="checkbox"/> Symmetrical design | <input type="checkbox"/> PC motherboards-plug and play protection |

HF RoHS REACH Pb Free

1. Electrical Characteristics

Model	I-hold	I-trip	Vmax	Imax	Pd typ	Max. Time to trip		R0 min	R1max
						Current	Time		
						(A)	(Sec.)		
MF-USMF005-2	0.05	0.15	30.00	10.00	0.60	0.25	1.50	2.80	50.00
MF-USMF010-2	0.10	0.30	30.00	10.00	0.60	0.50	1.50	1.50	15.00
MF-USMF020-2	0.20	0.40	24.00	10.00	0.60	8.00	0.02	0.80	5.00
MF-USMF050-2	0.50	1.00	13.20	100.00	0.60	8.00	0.10	0.18	0.90
MF-USMF075-2	0.75	1.50	6.00	100.00	0.60	8.00	0.10	0.10	0.45
MF-USMF110-2	1.10	2.20	8.00	100.00	0.60	8.00	0.10	0.05	0.21
MF-USMF150-2	1.50	3.00	6.00	100.00	0.80	8.00	0.30	0.03	0.11
MF-USMF175-2	1.75	3.50	6.00	100.00	0.80	8.00	0.60	0.02	0.09
MF-USMF200-2	2.00	4.00	6.00	100.00	0.80	8.00	1.00	0.015	0.090

I-hold: Holding Current: maximum current at which the device will not trip in 25°C still air.
 I-trip: Tripping Current: minimum current at which the device will trip in 25°C still air.
 Vmax: Maximum voltage device can withstand without damage at rated current(Imax).
 Imax: Maximum fault current device can withstand without damage at rated voltage(Vmax).
 Pd typ: Typical power dissipated from device when in the tripped state at 25°C still air.
 R0 min: Minimum resistance of device in initial (un-soldered) state.
 R1 max: Maximum resistance of device at 25°C measured one hour after tripping or reflow soldering of 260°C for 20 sec.

2. Product Dimensions(mm)&Marking

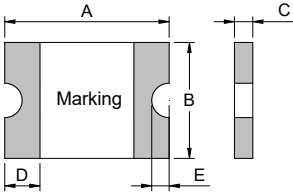

Model	A		B		C		D		E	Marking	Quantity pcs/R
	Min	Max	Min	Max	Min	Max	Min	Max	Min		
MF-USMF005-2	3.00	3.43	2.35	2.80	0.65	1.15	0.25	0.75	0.10	005	3500
MF-USMF010-2	3.00	3.43	2.35	2.80	0.65	1.15	0.25	0.75	0.10	010	3500
MF-USMF020-2	3.00	3.43	2.35	2.80	0.65	1.15	0.25	0.75	0.10	020	3500
MF-USMF050-2	3.00	3.43	2.35	2.80	0.35	0.85	0.25	0.75	0.10	050	4000
MF-USMF075-2	3.00	3.43	2.35	2.80	0.35	0.85	0.25	0.75	0.10	075	4000
MF-USMF110-2	3.00	3.43	2.35	2.80	0.35	0.85	0.25	0.75	0.10	110	4000
MF-USMF150-2	3.00	3.43	2.35	2.80	0.65	1.15	0.25	0.75	0.10	150	3500

MF-USMF175-2	3.00	3.43	2.35	2.80	0.65	1.15	0.25	0.75	0.10	175	3500
MF-USMF200-2	3.00	3.43	2.35	2.80	0.65	1.15	0.25	0.75	0.10	200	3500

3. Thermal Derating Chart

Recommended hold current(A) at ambient Temperature(°C)

I-hold	Ambient Operating Temperature								
	-40°C	-20°C	0°C	25°C	40°C	50°C	60°C	70°C	85°C
0.05A	0.08	0.07	0.06	0.05	0.04	0.04	0.03	0.03	0.02
0.10A	0.16	0.14	0.12	0.10	0.08	0.07	0.06	0.05	0.04
0.20A	0.29	0.26	0.22	0.20	0.16	0.14	0.13	0.11	0.08
0.35A	0.47	0.45	0.40	0.35	0.33	0.28	0.24	0.21	0.18
0.50A	0.76	0.67	0.58	0.50	0.43	0.40	0.36	0.32	0.28
0.75A	1.00	0.97	0.86	0.75	0.64	0.59	0.54	0.48	0.40
1.10A	1.60	1.42	1.26	1.10	0.94	0.86	0.80	0.70	0.58
1.50A	2.30	2.02	1.76	1.50	1.24	1.11	1.00	0.85	0.65
1.75A	2.45	2.22	2.01	1.75	1.45	1.26	1.10	0.98	0.80
2.00A	2.60	2.44	2.35	2.00	1.78	1.67	1.50	1.45	1.10

4. Typical time to trip at 25°C

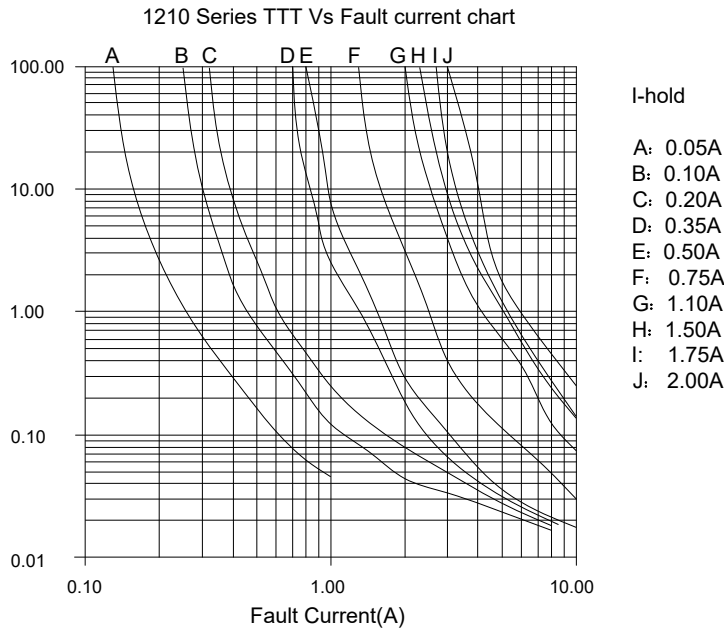

5. Soldering parameters

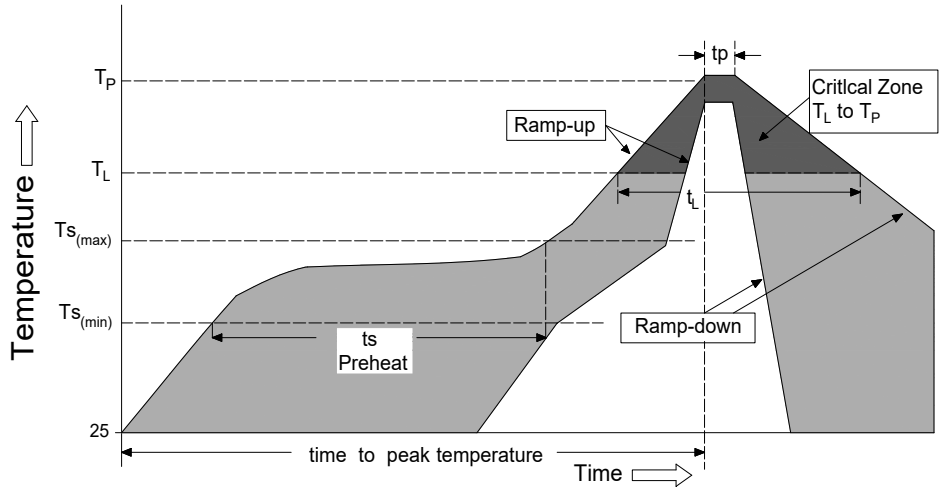

Profile Feature		Pb-Free Assembly
Average Ramp-Up Rate ($T_{s(max)}$ to T_P)		3°C/second max
Pre Heat:	Temperature Min ($T_{s(min)}$)	150°C
	Temperature Max ($T_{s(max)}$)	200°C
	Time (Min to Max) (t_s)	60 – 180 secs
Time Maintained Above:	Temperature (T_L)	217°C
	Temperature (t_L)	60 – 150 seconds
Peak / Classification Temperature (T_P)		260 ^{+0/-5} °C
Time within 5°C of actual peak Temperature (t_p)		20 – 40 seconds
Ramp-down Rate		6°C/second max
Time 25°C to peak Temperature (T_P)		8 minutes Max.

- ◆ All temperature refer to topside of the package, measured on the package body surface
- ◆ If reflow temperature exceeds the recommended profile, devices may not meet the performance requirements
- ◆ Recommended reflow methods: IR, vapor phase oven, hot air oven, N2 environment for lead
- ◆ Recommended maximum paste thickness is 0.25mm (0.010inch)
- ◆ Devices can be cleaned using standard industry methods and solvents

6. Recommended Pad Layout(mm) & Physical Specifications

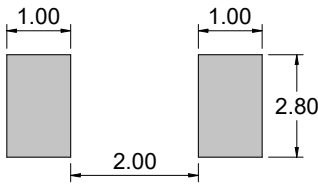

Terminal Material	Tin-Plated Nickel-Copper (Solder Material: Matte Tin (Sn))
Lead Solderability	Meets EIA Specification RS186-9E, ANSI/J-STD-002 Category 3.

7. Environmental Specifications

Operating Temperature	-40 °C to +85 °C
Maximum Device Surface Temperature in Tripped State	125°C
Passive Aging	+85 °C, 1000 hours ; ±5 % typical resistance change
Humidity Aging	+85 °C, 85 % R.H. 1000 hours; ±5 % typical resistance change
Thermal Shock	MIL-STD-202, Method 107; +85 °C to -40 °C, 20 times; -30 % typical resistance change
Solvent Resistance	MIL-STD-202, Method 215 ; No change
Vibration	MIL-STD-883, Method 2007, Condition A; No change
Moisture Sensivity Level	Level 1, J-STD-020
Storage Conditions	+40 °C Max. 70% RH Max. Packed in original packaging.

8. Test Procedures And Requirements

No.	Test	Test Conditions	Accept/Reject Criteria
-----	------	-----------------	------------------------

1	R0 min	Resistance measurement at 25°C	$R_{0min} \leq R \leq R_{1max}$
2	R1 max	Resistance measurement one hour after post trip	$R_{0min} \leq R \leq R_{1max}$
3	I-hold	Hold rated current 1800 second without trip, @ 25°C	No trip
4	I-trip	Device must trip within 900 second under rated current, @25°C	Trip
5	Max. time to trip	At specified current, 25 °C	$T \leq \text{max. time to trip (seconds)}$
6	Trip Cycle Life	$V_{max}, I_{max}, 100$ cycles	No arcing or burning
7	Trip Endurance	V_{max}, I_{max} 24 hours	No arcing or burning
8	Solderability	ANSI/J-STD-002	95 % min. coverage

9. Tape and Reel Specifications & Packaging quantity per Reel

TAPE SPECIFICATIONS: EIA-481-1 (mm)		
Q'ty	4,000pcs/Reel	3,500pcs/Reel
W	8.10±0.10	8.10±0.10
F	3.50±0.05	3.50±0.05
E1	1.75±0.10	1.75±0.10
D0	1.55±0.05	1.55±0.05
D1	1.00 min	1.00 min
P0	4.0±0.10	4.0±0.10
P1	4.0±0.10	4.0±0.10
P2	2.0±0.05	2.0±0.05
A0	3.00±0.10	3.00±0.10
B0	3.50±0.10	3.50±0.10
T	0.25±0.05	0.25±0.05
K0	0.85±0.10	1.22±0.10
Leader	390mm	390mm
Trailer	160mm	160mm

REEL DIMENSIONS: EIA-481-1 (mm)	
C	Ø178±1.0
D	Ø60.2±0.5
W	9.0±1.5
H	11.0±0.5

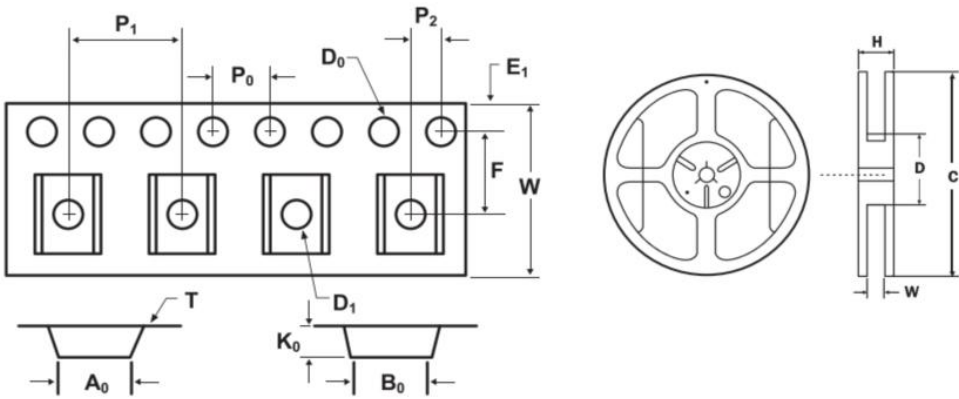

10. Part Ordering Number System

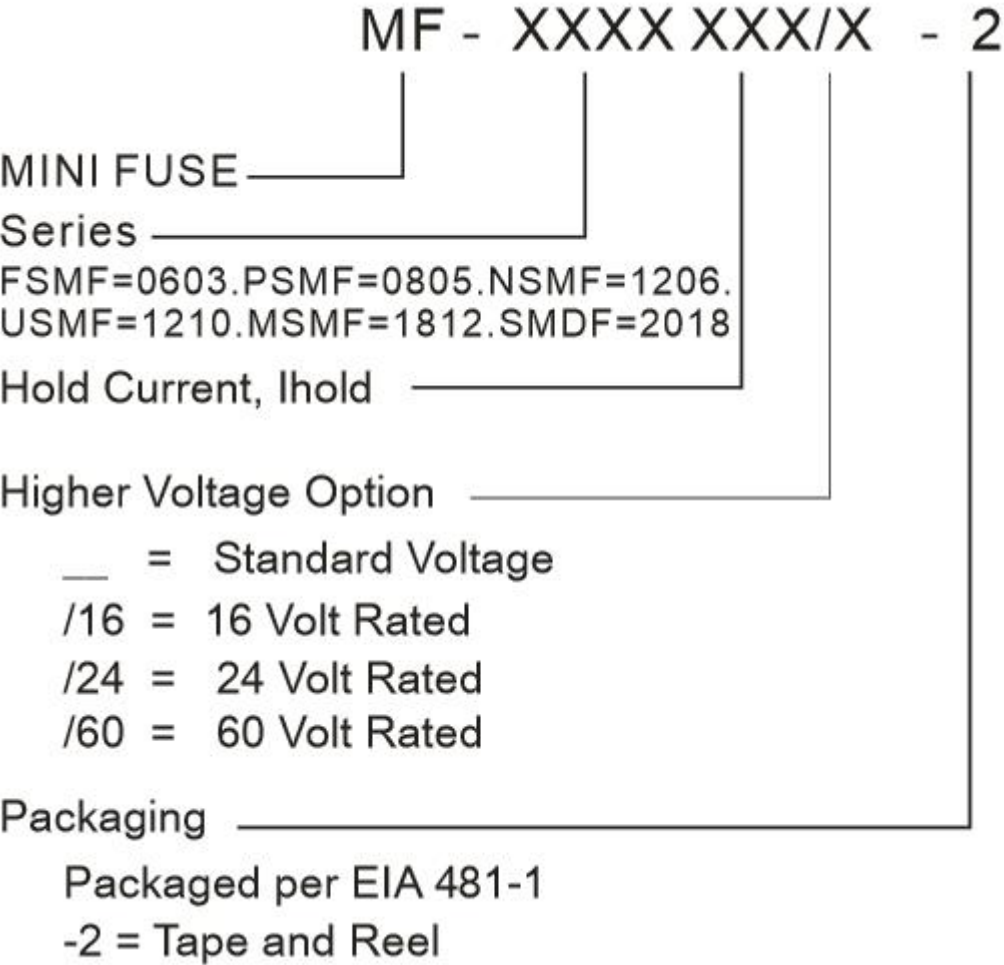

APPLICATION NOTICE

1. Operation of these PPTC devices beyond the stated maximum ratings could result in damage to the devices and lead to electrical arcing and/or fire.

PPTC 器件在超过规定的最大值额定值运行可能会导致器件损坏以及导致电弧和/或火灾。

2. These PPTC devices are intended to protect against the effects of temporary over-current or over-temperature conditions and shall not be taken for use as switch, Multiple times tripping shall lower the PPTC hold current.

PPTC 的作用是防止临时的过流或过温造成的不良影响，不能当作开关使用，重复多次的保护会降低 PPTC 的维持电流。

3. Exposure to lubricants, silicon-based oils, solvents, gels, electrolytes, acids, and other related or similar materials may adversely affect the performance of PPTC devices.

PPTC 接触润滑剂、硅基油、溶剂、凝胶、电解质、酸和其他相关或类似材料可能会对 PPTC 器件的性能有不利影响。

4. Circuits with inductance may generate a voltage above the rated voltage of the PPTC device and should be thoroughly evaluated within the user's application during the PPTC selection and qualification process.

带有电感的电路可能产生高于 PPTC 额定电压的电压，因此客户在选型和认定过程中应进行彻底的评估。

5. Please do not smash, clamp, pull, dent or twist by tool during assembling process, as they may result in the PPTC damage.

在装配过程中，避免有砸、挤、拉、扭等方式外力作用于 PPTC 本体上，因为它们可能导致 PPTC 损坏。

6. The above parameters are concluded from one time of reflow soldering processing the PPTC. If there is any further heat generated process like injection or dispensing at the customer's premise, the aforementioned parameters will decrease at certain degree. Therefore the verification test to be conducted is necessary .

规格书所规定的电阻以及电气特性，均是基于在指经过一次回流焊之后的测试。如果客户有二次回流焊或者注塑点胶等其他热工序，会对上述参数有一定程度的衰减。所以需要验证其适用性。

7. When mounting or using PPTC, all injection molding materials, curing adhesives, UV glue , silica gel and cleaning agents or solvents must be tested in terms of application parameters e.g. temperature, time, and etc to ensure the consistency between the product and the processing before use.

PPTC 贴装或应用过程中,所使用到的各类注塑料、单组份、双组份固化胶粘剂、硅胶、清洁剂、溶剂等，需要对注塑料胶料等材料的应用参数（如温度、时间等）进行验证，以确保产品及工艺的匹配性，确认不会影响 PPTC 性能之后方可使用。

8. The PPTC is thermal sensitive device. It is recommended not to design any heat source devices around it to reduce the outside heat source impact.

PPTC 为热敏元件，对环境温度比较敏感，建议在 PPTC 周围不要设计热源元件，尽量减少外部热源的影响。

9. SMD PPTC is designed for SMT processing which applies reflow soldering. Please refer to the JMT recommended curve for reference. If the reflow soldering temperature exceeds the recommended value, the PPTC might be damaged. Hand welding PPTC is prohibited, if there is soldering iron welding process, it is suggested that the welding position should be more than 1.5mm away from PPTC, the welding tool temperature should be lower than 350°C, and the contact time between soldering iron and solder joint should not exceed 3sec..

PPTC 贴片产品是为 SMT 工艺设计的封装形式，焊接工艺为回流焊。焊接工艺可参考晶美特推荐的回流焊曲线。如果回流焊温度超过推荐的值，PPTC 将有可能受到损伤。禁止使用手工焊接 PPTC，如有烙铁焊接工艺，建议焊接位置距离 PPTC 1.5mm 以上，焊接工具温度低于 350°C，焊接铁头与焊点的接触时间不超过 3sec。

10. In charging terminal application, PP type material is recommended to use as inner membrane and TPE and PVC type material is inhibited

PPTC 在充电线端应用中，建议使用 PP 类材料做内膜，禁止使用 TPE 类与 PVC 类等材料做内膜。

单击下面可查看定价，库存，交付和生命周期等信息

[>>JEMETE\(晶美特\)](#)