

General Description

The SY89001 develops a high efficiency synchronous step-down DC/DC converter capable of delivering 1A current. The SY89001 operates over a wide input voltage range from 7V to 100V and integrates main switch and synchronous switch with very low $R_{DS(ON)}$ to minimize the conduction loss. The SY89001 always operates under continuous condition mode. The device adopts the instant PWM architecture to achieve fast transient responses for high step down applications.

Ordering Information

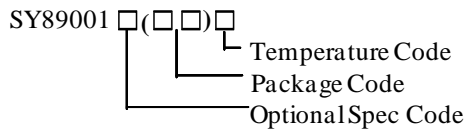

Ordering Number	Package type	Note
SY89001FCC	SO8E	--

Features

- Low $R_{DS(ON)}$ for Internal Switches (Top/Bottom): 500mΩ/240mΩ
- 7-100V Input Voltage Range
- 1A Output Current Capability
- Constant On-time Control
- Instant PWM Architecture to Achieve Fast Transient Responses
- Programmable Switching Frequency Range: 200kHz ~600kHz
- 2ms Internal Soft-start Limits the Inrush Current
- Precise $\pm 2\%$ 1.225V Reference over -40°C to $+125^{\circ}\text{C}$ Temperature Range
- Cycle-by-cycle Peak Current Limit
- Over Temperature Protection with Auto Recovery
- RoHS Compliant and Halogen Free
- Compact Package SO8E

Applications

- Isolated Telecom Bias Supply
- Secondary High Voltage Post Regulator
- Automotive Systems

Typical Applications

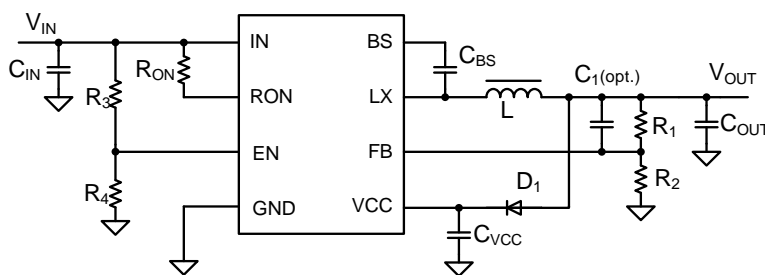

Figure1. Schematic Diagram

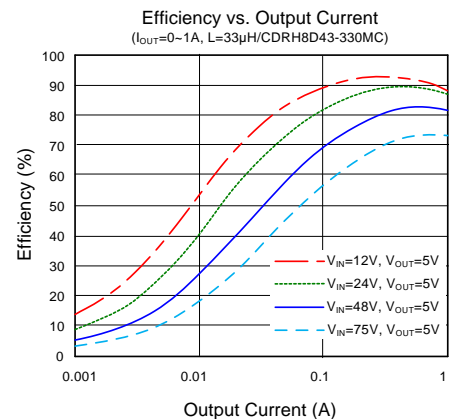
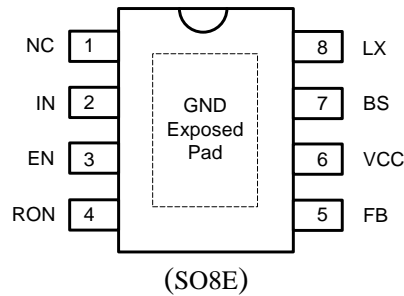

Figure2. Efficiency vs. Output Current

Pinout (top view)



Top Mark: CRDxyz (Device code: CRD; x=year code, y=week code, z=lot number code)

Pin Name	Pin Number	Pin Description
NC	1	Not connected.
IN	2	Input pin. Decouple this pin to GND with a low ESR ceramic capacitor.
EN	3	Enable control pin. This pin can also be used for programming V_{IN} turn on voltage with the resistor divider. The device has an accurate 1.225V rising threshold.
RON	4	Connect a resistor from this pin to the IN to set the top switch ON time. The switching frequency can be calculated using the following equation: $f_s (\text{kHz}) = \frac{11 \times V_{OUT} (\text{V}) + 500}{R_{ON} (\text{M}\Omega)}$
FB	5	Output feedback pin. Connect this pin to the center point of the output resistor divider (as shown in Figure 1) to program the output voltage: $V_{OUT} = 1.225 \times (1 + R_1/R_2)$
VCC	6	Supply input of internal LDO.
BS	7	Boot-Strap Pin. Supply high side gate driver. Decouple this pin to LX pin with 0.1uF ceramic capacitor.
LX	8	Inductor pin. Connect this pin to the switching node of inductor
GND	Exposed Pad	Ground pin.

Block Diagram

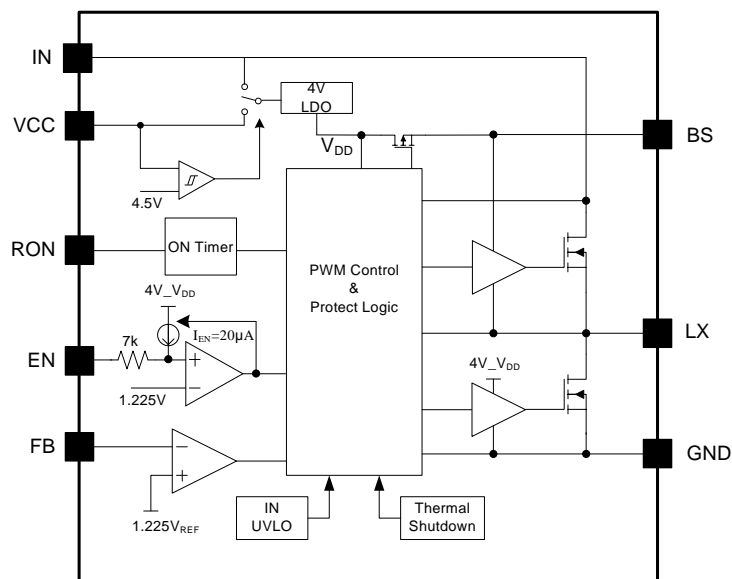

Figure3. Block Diagram



Absolute Maximum Ratings (Note 1)

IN	-0.3V to 100V
EN, RON	-0.3V to $V_{IN} + 0.3V$
LX	-0.7V to $V_{IN} + 0.3V$
BS-LX	-0.3V to 6V
FB Voltage	-0.3V to 6V
VCC	-0.3V to 30V
Power Dissipation, P_D @ $T_A = 25^\circ C$, SO8E	3.3W
Package Thermal Resistance (Note 2)	
θ_{JA}	30°C/W
θ_{JC}	10°C/W
Junction Temperature Range	-40°C to 150°C
Lead Temperature (Soldering, 10 sec.)	260°C
Storage Temperature Range	-65°C to 150°C
Dynamic LX voltage in 50ns Duration	$V_{IN}+3V$ to GND-5V

Recommended Operating Conditions (Note 3)

Supply Input Voltage	7V to 100V
Junction Temperature Range	-40°C to 125°C
Ambient Temperature Range	-40°C to 85°C

Electrical Characteristics

($V_{IN}=48V$, $V_{OUT}=5V$, $L=33\mu H$, $C_{OUT}=10\mu F$, $I_{OUT}=1A$ unless otherwise specified. Typical value correspond to $T_J=25^\circ C$. Minimum and maximum limits apply over $-40^\circ C$ to $125^\circ C$ junction temperature range.)

Parameter	Symbol	Test Conditions	Min	Typ	Max	Unit
Input Voltage Range	V_{IN}		7		100	V
Input UVLO Rising Threshold	$V_{IN,UVLO}$		5.8	6.3	6.8	V
Input UVLO Hysteresis	V_{HYS}			0.25		V
Shutdown Current	I_{SHDN}	EN=0		8	30	μA
Feedback Reference Voltage	V_{REF}		1.2	1.225	1.25	V
FB Input Current	I_{FB}	$V_{FB}=3.3V$	-50		50	nA
Top FET RON	$R_{DS(ON)1}$			500		m Ω
Bottom FET RON	$R_{DS(ON)2}$			240		m Ω
Top FET peak Current Limit	$I_{LIM, TOP}$		1.4		2.2	A
Bottom FET Valley Current Limit	$I_{LIM, BOTTOM}$		1			A
Negative Current Limit	$I_{LIM, NEG}$			-1.5		A
VCC Input Rising UVLO Threshold	$V_{VCC, UVLO}$			4.5		V
VCC Input UVLO Hysteresis	$V_{VCC, HYS}$			0.3		V
EN Rising Threshold	V_{EN}		1.185	1.225	1.265	V
EN Hysteresis Input Current	$I_{EN, HYS}$		-10	-20	-29	μA
Switching Frequency	f	$V_{IN}=48V$, $R_{L}=1.1M\Omega$	350	500	650	kHz
Min ON Time	t_{ON}			90		ns
Min OFF Time	t_{OFF}			200		ns
Thermal Shutdown Temperature	T_{SD}			150		$^\circ C$
Thermal Shutdown Hysteresis	T_{HYS}			15		$^\circ C$

Note 1: Stresses beyond the “Absolute Maximum Ratings” may cause permanent damage to the device. These are stress ratings only. Functional operation of the device at these or any other conditions beyond those indicated in the operational sections of the specification is not implied. Exposure to absolute maximum rating conditions for extended periods may affect device reliability.

Note 2: θ_{JA} is measured in the natural convection at $T_A = 25^\circ C$ on a low effective 4-layer thermal conductivity test board of JEDEC 51-3 thermal measurement standard. Paddle of SO8E package is the case position for θ_{JC} measurement.

Note 3: The device is not guaranteed to function outside its operating conditions.

SO8E Package Outline & PCB layout

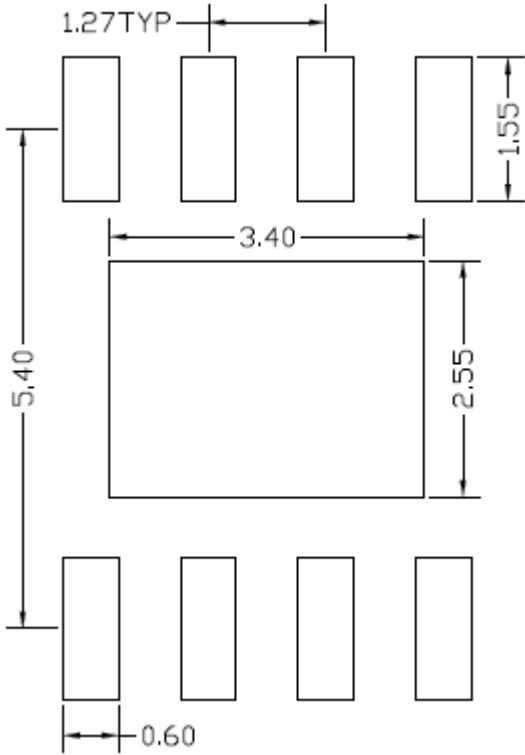

**Recommended PCB Layout
(Reference Only)**

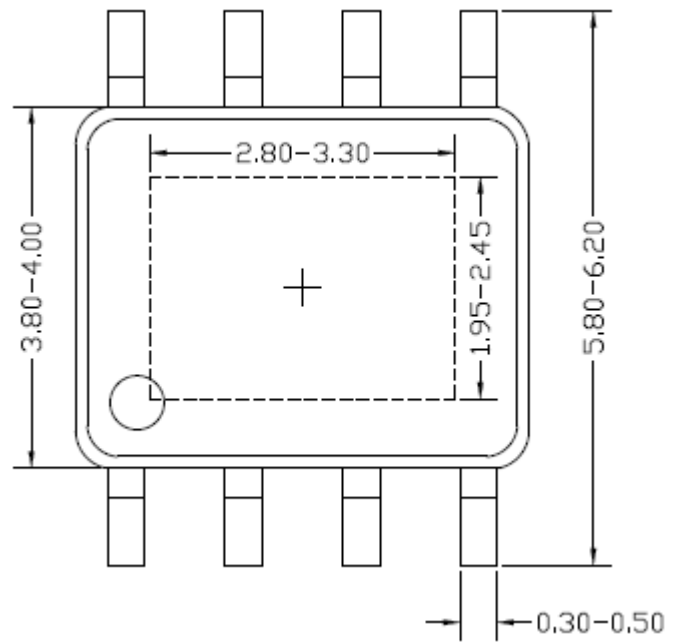

Top view

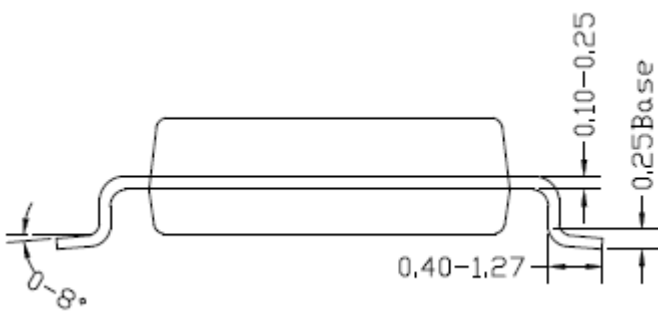

Side view

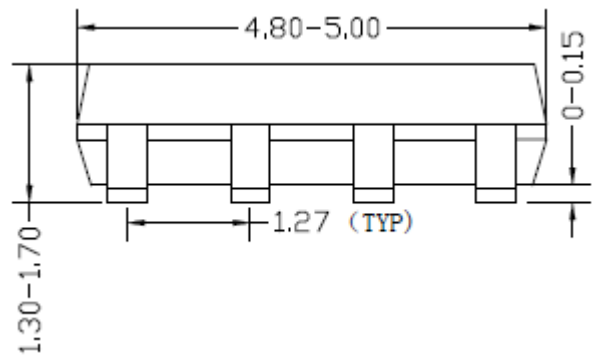

Front view

Notes: All dimension in millimeter and exclude mold flash & metal burr.

Taping & Reel Specification

1. Taping orientation

SO8E

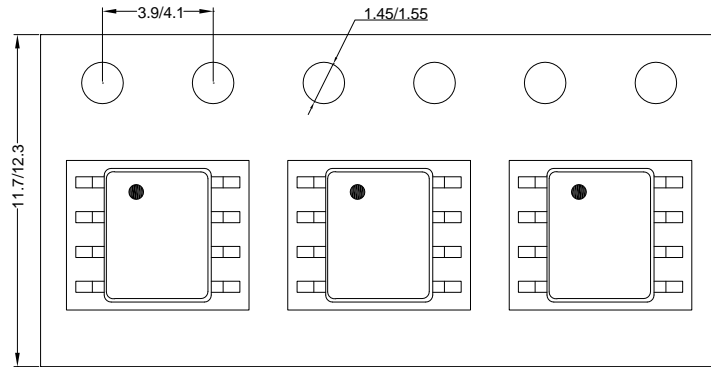

Feeding direction →

2. Carrier Tape & Reel specification for packages

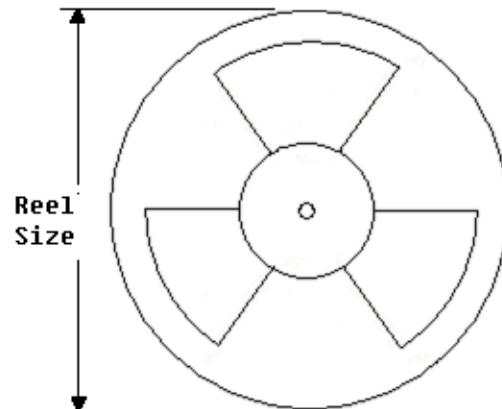

Package type	Tape width (mm)	Pocket pitch(mm)	Reel size (Inch)	Trailer length(mm)	Leader length (mm)	Qty per reel
SO8E	12	8	13"	400	400	2500

3. Others: NA

单击下面可查看定价，库存，交付和生命周期等信息

[>>SILERGY\(矽力杰\)](#)