

© 2023 TE Connectivity. All Rights Reserved.

REVISIONS

| PART NUMBER | REV | FIRST USED | DESCRIPTION |
|-------------|-----|------------|--------------|
| 2418020-1 | B | - | AP-3T L TO R |
| 2418020-3 | B | - | AP-3T R TO L |
| 1-2418020-1 | B | - | AP-5T L TO R |
| 1-2418020-3 | B | - | AP-5T R TO L |

| P | LTR | DESCRIPTION | DATE | DWN | APVD |
|---|-----|----------------------|-----------|-----|------|
| A | | INITIAL RELEASE | 18MAY2023 | M.Y | J.W |
| B | | DOCUMENTATION UPDATE | 19JUL2024 | W.Z | M.Y |

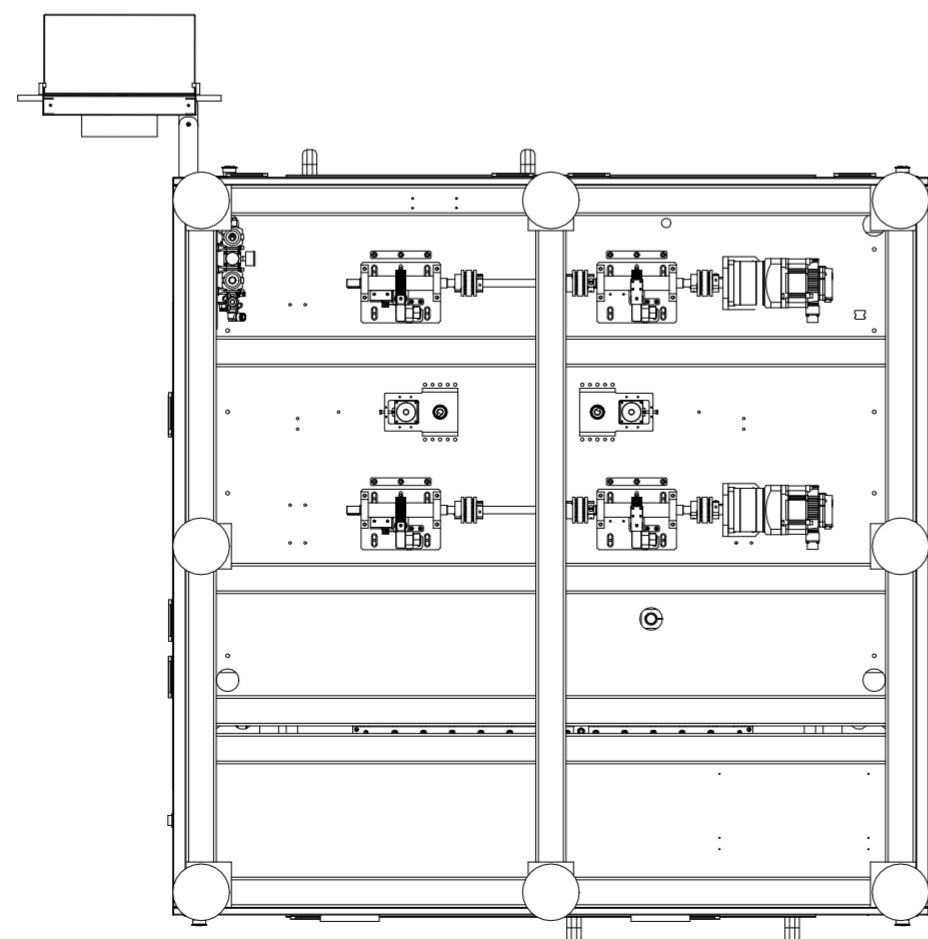
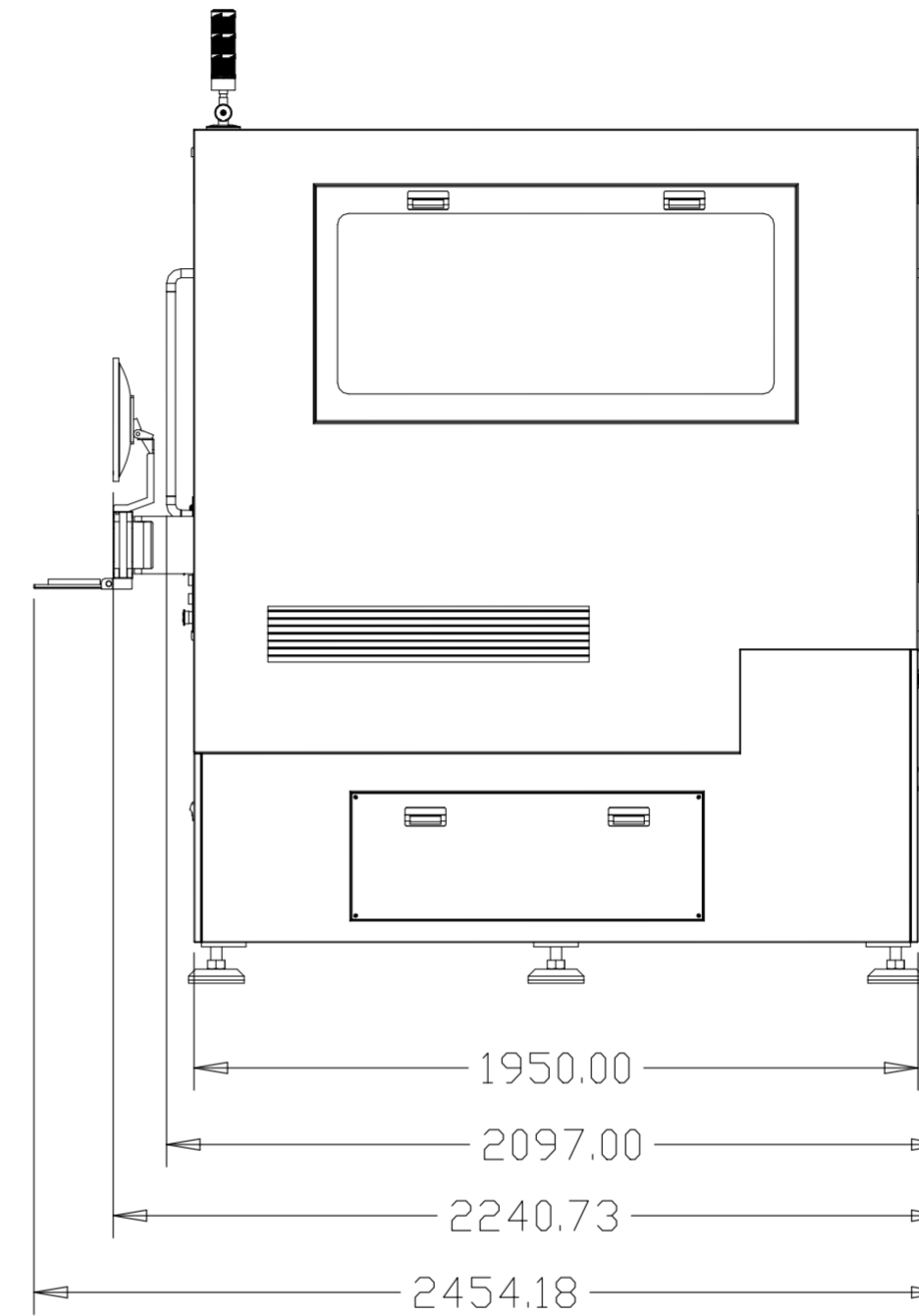
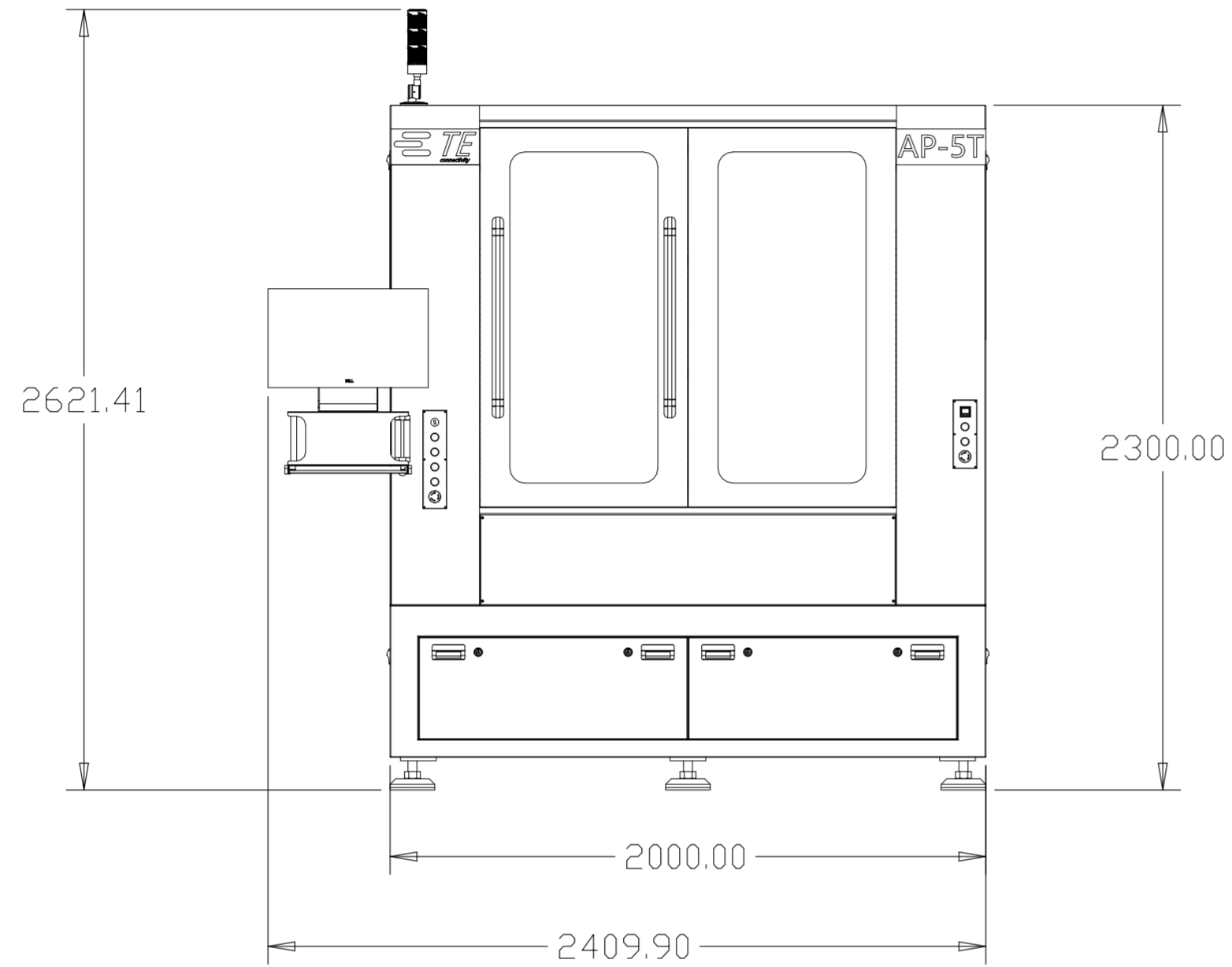

1. FOR RECOMMENDED SPARE PARTS, SEE SHEET 2.
2. REFERENCE ELECTRICAL SCHEMATIC 2418023-1
3. REFERENCE PNEUMATIC SCHEMATIC 2418022-1
4. THERE ARE TWO TYPES OF MATERIAL FEEDING FOR AP MACHINE. EITHER PCB WILL ENTER FROM THE LEFT AND EXIT FROM THE RIGHT, OR ENTER FROM THE RIGHT AND EXIT FROM THE LEFT

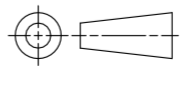
| | | | | | |
|---|--|-----------------------------|---|--|--|
| THIS DRAWING IS A CONTROLLED DOCUMENT. | | DWN M.YANG 18MAY2023 |  TE Connectivity | | |
| DIMENSIONS: mm | | CHK J.WANG 18MAY2023 | | | |
|  | | APVD J.WANG 18MAY2023 | NAME AP-3T/5T AUTOMATIC IN-LINE SERVO PRESS | | |
| TOLERANCES UNLESS OTHERWISE SPECIFIED: | | PRODUCT SPEC | SIZE | | |
| 0 PLC ± | | APPLICATION SPEC | CAGE CODE | | |
| 1 PLC ± | | | DRAWING NO | | |
| 2 PLC ± | | | RESTRICTED TO | | |
| 3 PLC ± | | | A200779 | | |
| 4 PLC ± | | | C-2418020 | | |
| ANGLES ± | | WEIGHT | SCALE 1:20 | | |
| FINISH | | CUSTOMER DRAWING | SHEET 1 OF 2 | | |
| | | | REV A | | |

REVISIONS

| P | LTR | DESCRIPTION | DATE | DWN | APVD |
|---|-----|-------------|------|-----|------|
| | | SEE SHEET 1 | | | |
| | | | | | |
| | | | | | |

SPARE PARTS LIST

| ITEM NO | TE PN | DESCRIPTION | -1 |
|---------|-------------|-------------------|----|
| 1 | 4-2418024-0 | COPPER BUSHING | 5 |
| 2 | 4-2418024-1 | SYNCHRONOUS WHEEL | 1 |
| 3 | 4-2418024-2 | SYNCHRONOUS WHEEL | 1 |
| 4 | 4-2418024-3 | SYNCHRONOUS BELT | 2 |
| 5 | 4-2418024-4 | SYNCHRONOUS BELT | 2 |
| 6 | 4-2418024-5 | AIR CYLINDER | 1 |
| 7 | 4-2418024-6 | MAGNETIC SWITCH | 4 |
| 8 | 4-2418024-7 | SYNCHRONOUS WHEEL | 1 |
| 9 | 4-2418024-8 | SYNCHRONOUS WHEEL | 1 |
| 10 | 4-2418024-9 | IDLE GEAR | 1 |
| 11 | 5-2418024-0 | SYNCHRONOUS BELT | 1 |
| 12 | 5-2418024-1 | SYNCHRONOUS WHEEL | 1 |
| 13 | 5-2418024-2 | SYNCHRONOUS WHEEL | 1 |
| 14 | 5-2418024-3 | SYNCHRONOUS WHEEL | 1 |
| 15 | 5-2418024-4 | SYNCHRONOUS BELT | 2 |
| 16 | 5-2418024-5 | AIR CYLINDER | 1 |
| 17 | 5-2418024-7 | AIR CYLINDER | 1 |
| 18 | 5-2418024-8 | MAGNETIC SWITCH | 2 |
| 19 | 5-2418024-9 | AIR CLAMP | 2 |

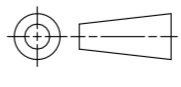
| | | | | | |
|---|--|-----------------------------|---|--------------------|-------------------------|
| THIS DRAWING IS A CONTROLLED DOCUMENT. | | DWN E.CHEN 10OCT2023 |  TE Connectivity | | |
| | | CHK M.YANG 10OCT2023 | | | |
| DIMENSIONS: MM | | APVD M.YANG 10OCT2023 | NAME AP-3T/5T AUTOMATIC IN-LINE SERVO PRESS | | |
|  | | PRODUCT SPEC - | RESTRICTED TO - | | |
| TOLERANCES UNLESS OTHERWISE SPECIFIED: | | APPLICATION SPEC - | SIZE A2 | CAGE CODE 00779 | DRAWING NO C-2418020 |
| MATERIAL - | | WEIGHT - | SCALE 1:20 | | SHEET 2 OF 2 |
| | | CUSTOMER DRAWING | REV A | | |

单击下面可查看定价，库存，交付和生命周期等信息

[>>TE Connectivity\(泰科\)](#)