

Features

- Uses CRM advanced Trench technology
- Extremely low on-resistance $R_{DS(on)}$
- Excellent $Q_g \times R_{DS(on)}$ product(FOM)
- Qualified according to JEDEC criteria

Applications

- Motor control and drive
- Electrical tools
- Lithium battery protection

Product Summary

V_{DS}	-60V
$R_{DS(on)}$ typ.	42mΩ
I_D	-24A

100% DVDS Tested

100% Avalanche Tested

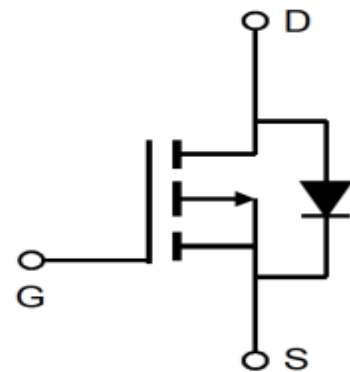
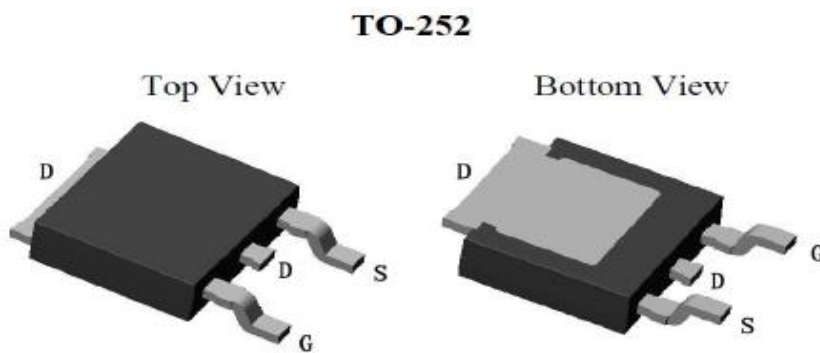

Package Marking and Ordering Information

Part #	Marking	Package	Packing	Reel Size	Tape Width	Qty
CRTD550P06N2-G	T550P06N2	TO-252	Reel	N/A	N/A	2500pcs

Absolute Maximum Ratings

Parameter	Symbol	Value	Unit
Drain-source voltage	V_{DS}	-60	V
Continuous drain current $T_C = 25^\circ\text{C}$ $T_C = 100^\circ\text{C}$	I_D	-24 -15.4	A
Pulsed drain current ($T_C = 25^\circ\text{C}$, t_p limited by T_{jmax})	$I_{D\ pulse}$	-96	A
Avalanche energy, single pulse ($L=0.5\text{mH}$)	E_{AS}	72	mJ
Gate-Source voltage	V_{GS}	± 18	V
Power dissipation ($T_C = 25^\circ\text{C}$)	P_{tot}	48.0	W
Operating junction and storage temperature	T_j, T_{stg}	-55...+150	$^\circ\text{C}$
Soldering temperature, wave soldering only allowed at leads (1.6mm from case for 10s)	T_{sold}	260	$^\circ\text{C}$

Thermal Resistance

Parameter	Symbol	Typ	Max	Unit
Thermal resistance, junction – case.	R_{thJC}	-	2.60	°C/W
Thermal resistance, junction – ambient(min. footprint)	R_{thJA}^{a2}	-	62.5	

Electrical Characteristic (at $T_j = 25\text{ }^\circ\text{C}$, unless otherwise specified)

Parameter	Symbol	Value			Unit	Test Condition
		min.	typ.	max.		

Static Characteristic

Drain-source breakdown voltage	BV_{DSS}	-	-	-60	V	$V_{GS}=0V, I_D=-250\mu A$
Gate threshold voltage	$V_{GS(th)}$	-1.5	-2.5	-3.5	V	$V_{DS}=V_{GS}, I_D=-250\mu A$
Zero gate voltage drain current	I_{DSS}	-	-	-1	μA	$V_{DS}=-60V, V_{GS}=0V$ $T_j=25^\circ C$ $T_j=150^\circ C$
Gate-source leakage current	I_{GSS}	-	-	± 100	nA	$V_{GS}=\pm 18V, V_{DS}=0V$
Drain-source on-state resistance	$R_{DS(on)}$	-	42	55.0	mΩ	$T_j=25^\circ C$ $V_{GS}=-10V, I_D=-12A$
Transconductance	g_{fs}		20.22		S	$V_{DS}=-5V, I_D=-5A$

Dynamic Characteristic

Input Capacitance	C_{iss}	-	2667	-	pF	$V_{GS}=0V, V_{DS}=-30V$ $f=1MHz$
Output Capacitance	C_{oss}	-	93	-		
Reverse Transfer Capacitance	C_{riss}	-	79	-		
Gate Total Charge	Q_g	-	41.2	-	nC	$V_{GS}=-10V, V_{DS}=-30V$ $I_D=-12A$
Gate-Source charge	Q_{gs}	-	8.95	-		
Gate-Drain charge	Q_{gd}	-	7.55	-		
Turn-on delay time	$t_{d(on)}$	-	17.46	-	ns	$V_{GS}=-10V,$ $V_{DS}=-30V$ $RG=3\Omega, RL=6\Omega$ $ID=-5A$
Rise time	t_r	-	4.54	-		
Turn-off delay time	$t_{d(off)}$	-	74.22	-		
Fall time	t_f	-	11.68	-		
Gate resistance	R_G	-	7.6	-	Ω	$V_{GS}=0V, V_{DS}=0V f=1MHz$

Body Diode Characteristic

Parameter	Symbol	Value			Unit	Test Condition
		min.	typ.	max.		
Body Diode Forward Voltage	V_{SD}	-	-	-1.2	V	$V_{GS}=0V, I_{SD}=-12A$
Body Diode Continuous Forward Current	I_S	-	-	-24	A	$T_C = 25^{\circ}C$
Body Diode Reverse Recovery Time	t_{rr}	-	26.83	-	ns	$I_F=-5A, dI/dt=100A/\mu s$
Body Diode Reverse Recovery Charge	Q_{rr}	-	29.44	-	nC	

a1: Calculated continuous current based on maximum allowable junction temperature. Note that current limitations arising from heating of the device leads may occur with some lead mounting arrangements.

a2: The value of R_{thJA} is measured by placing the device in a still air box which is one cubic foot.

Typical Performance Characteristics

Fig 1: Output Characteristics

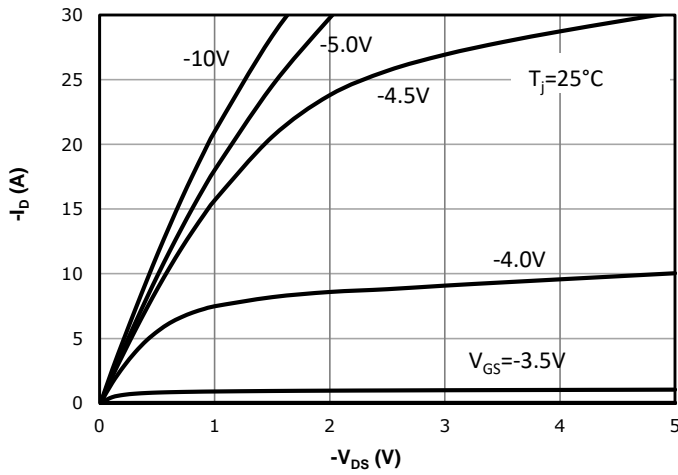

Fig 2: Transfer Characteristics

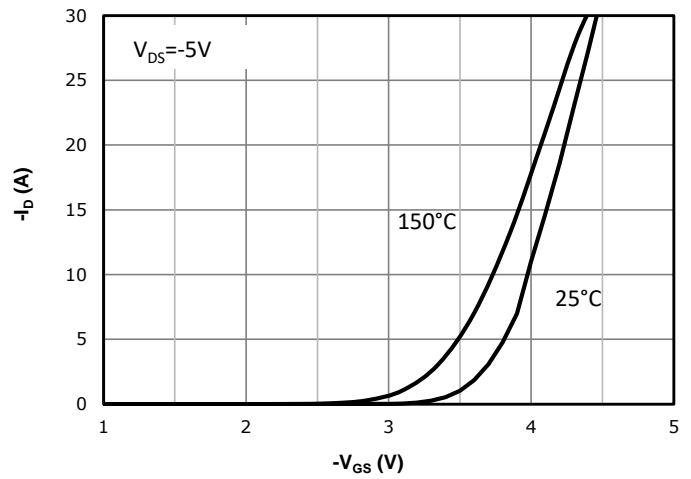

Fig 3: $R_{DS(on)}$ vs Drain Current and Gate Voltage

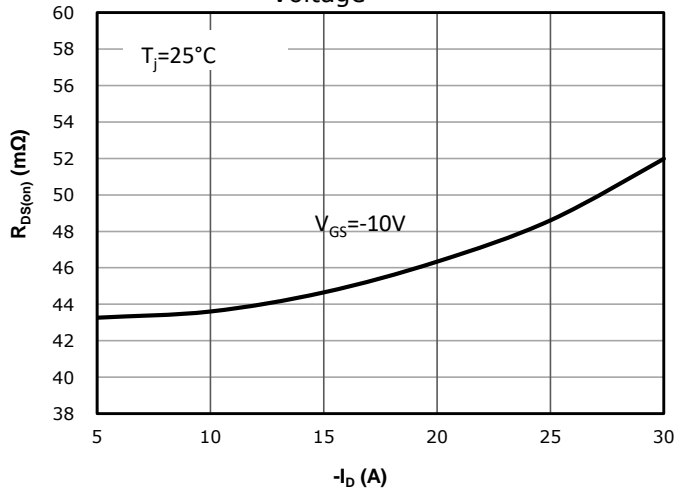

Fig 4: $R_{DS(on)}$ vs Gate Voltage

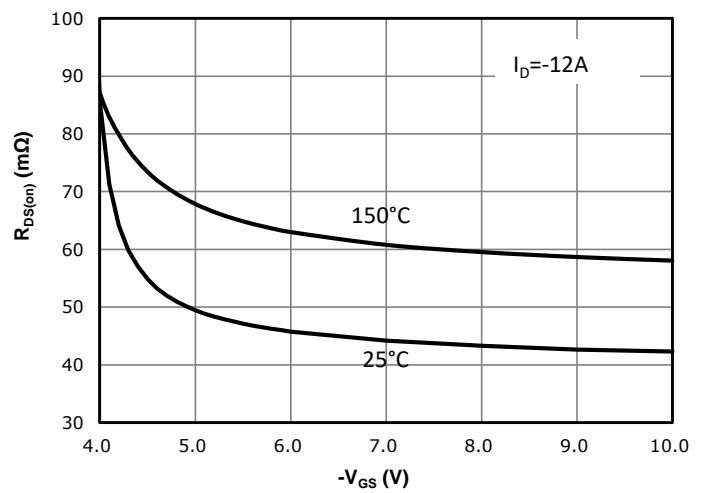

Fig 5: $R_{DS(on)}$ vs. Temperature

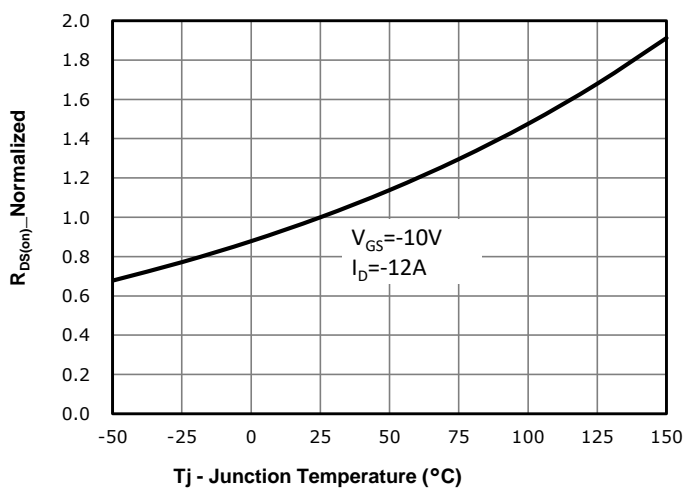

Fig 6: $V_{GS(th)}$ vs. Temperature

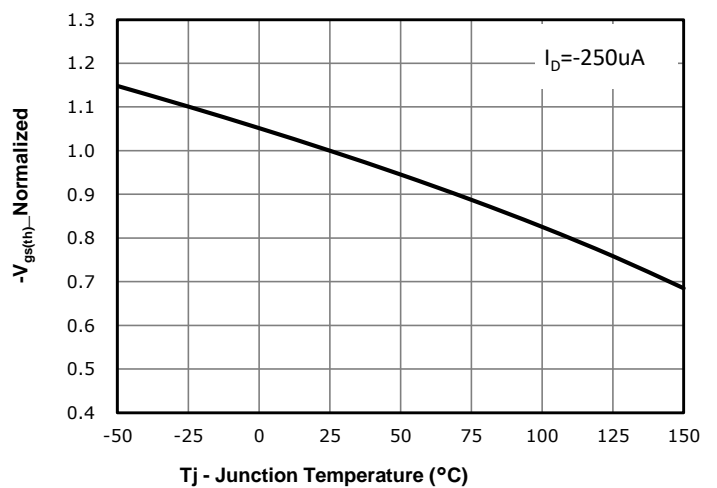

Fig 7: BVdss vs. Temperature

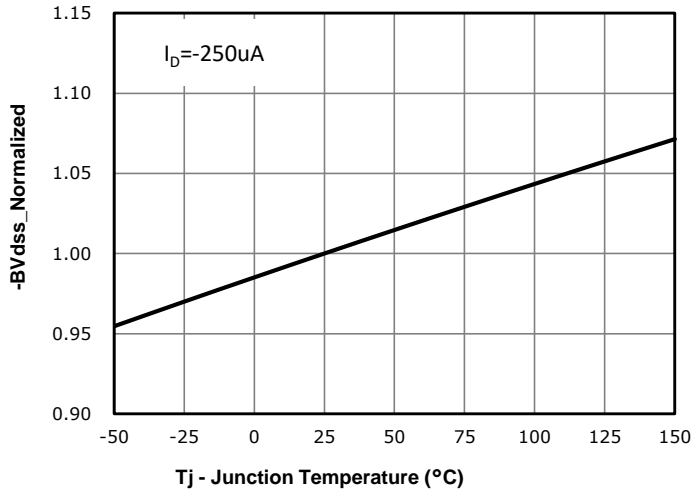

Fig 8: Body-diode Forward Characteristics

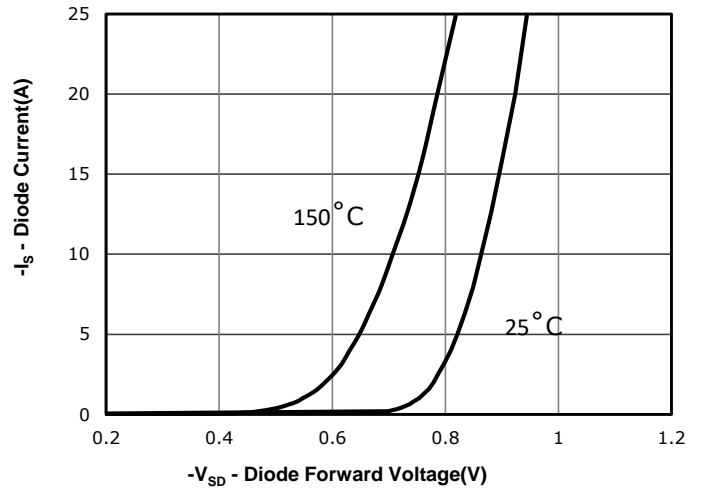

Fig 9: Gate Charge Characteristics

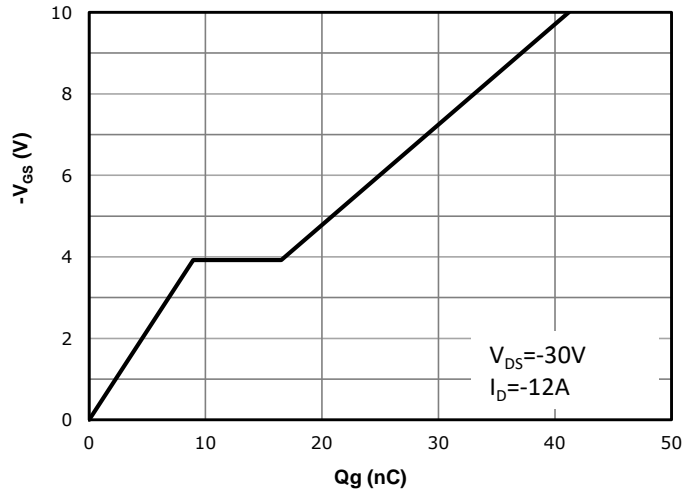

Fig 10: Capacitance Characteristics

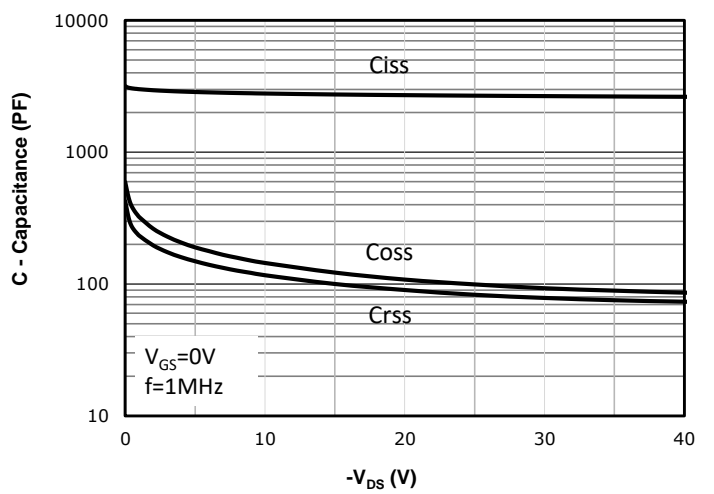

Fig 11: Drain Current Derating

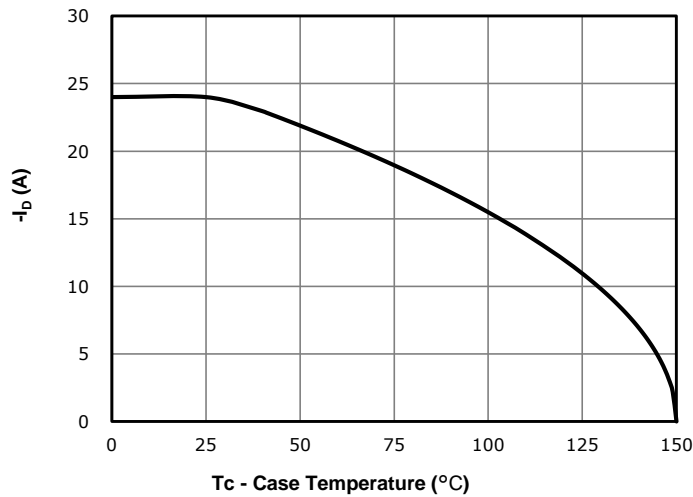

Fig 12: Power Dissipation

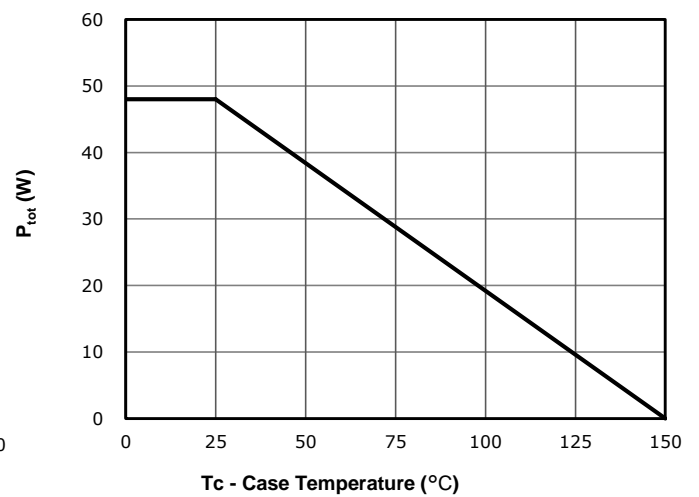

Fig 13: Safe Operating Area

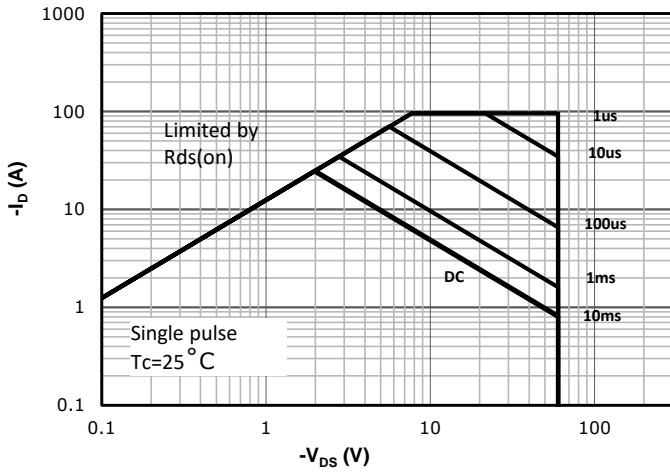
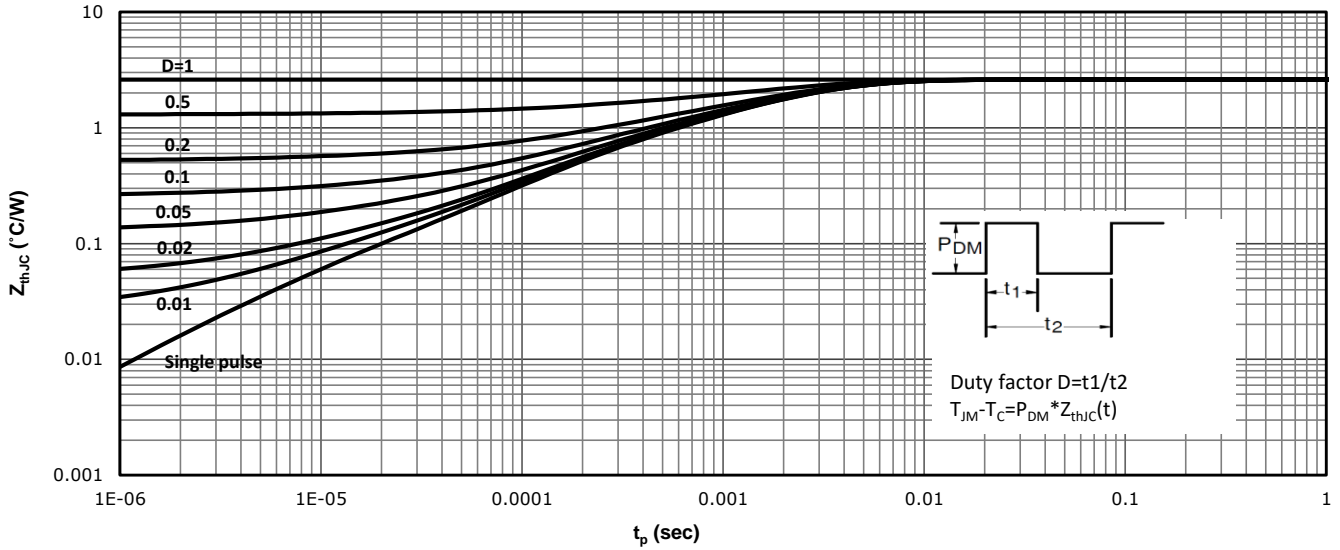
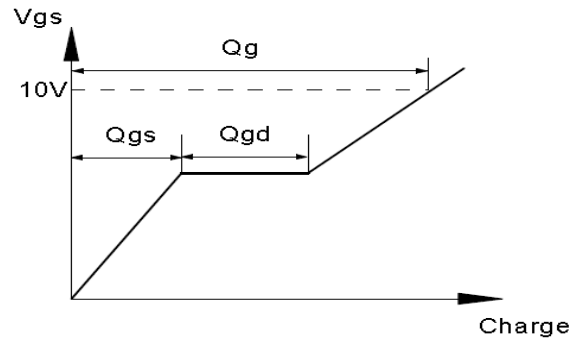
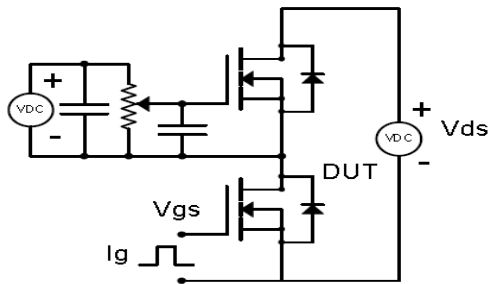

Fig 14: Max. Transient Thermal Impedance



Test Circuit & Waveform

Gate Charge Test Circuit & Waveform



Resistive Switching Test Circuit & Waveforms

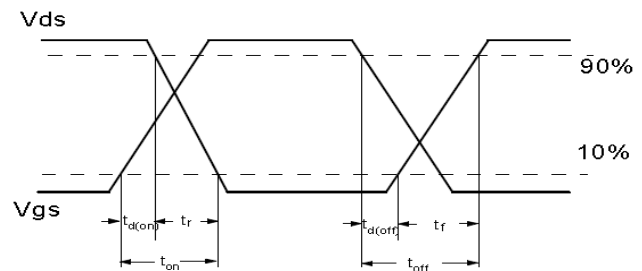
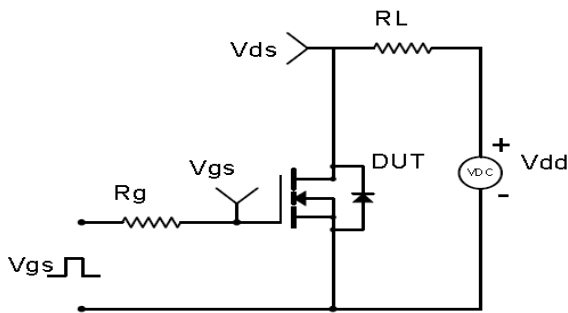

Unclamped Inductive Switching (UIS) Test Circuit & Waveforms

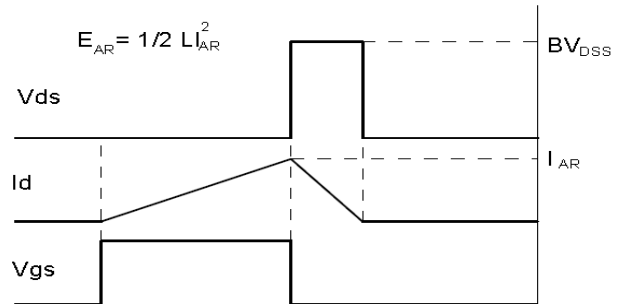
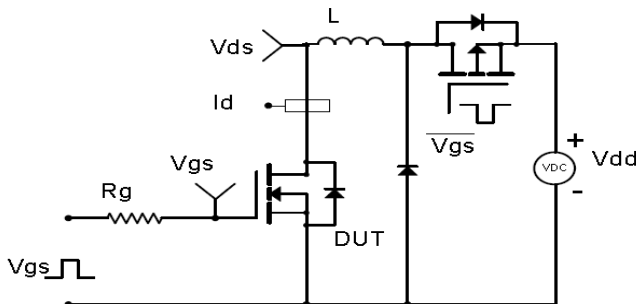

Diode Recovery Test Circuit & Waveforms

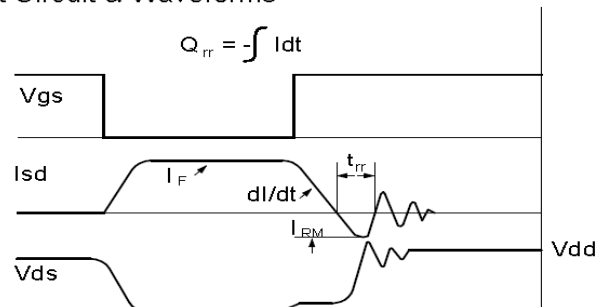
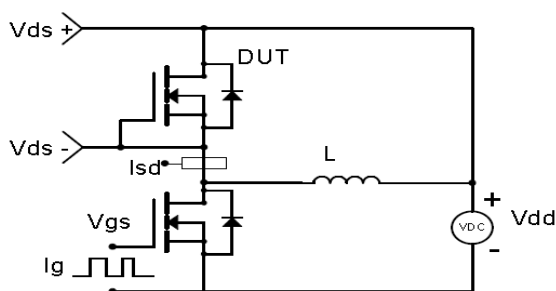

Package Outline: TO-252

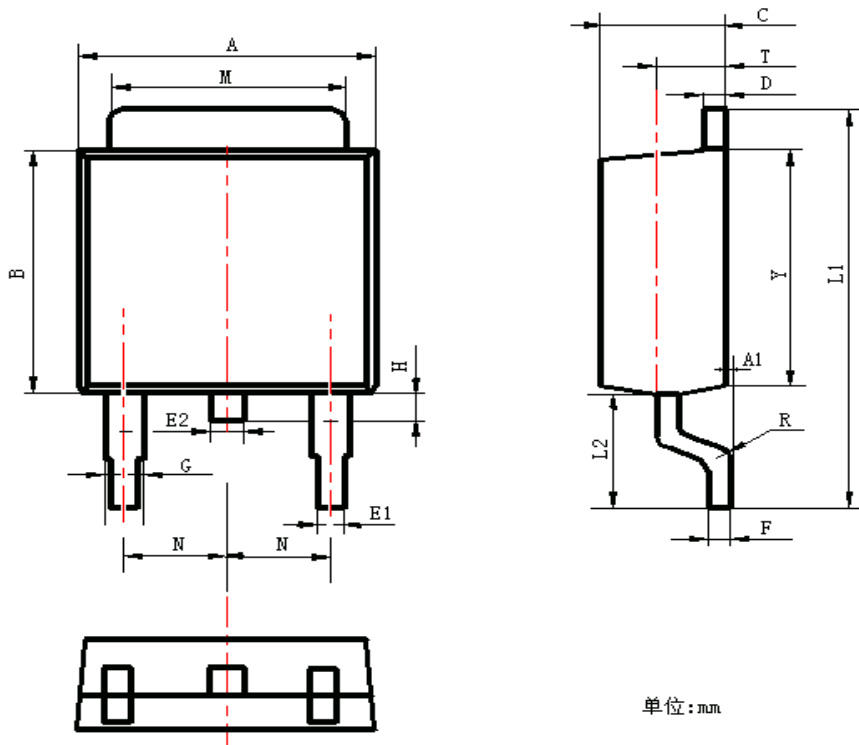

Symbol	Values(mm)	
	Min.	Max.
A	6.300	6.900
A1	0.000	0.160
B	5.700	6.300
C	2.100	2.500
D	0.300	0.700
E1	0.600	0.900
E2	0.700	1.000
F	0.300	0.600
G	0.700	1.200
L1	9.600	10.500
L2	2.700	3.100
H	0.400	1.000
M	5.100	5.500
N	2.090	2.490
R	0.300	
T	1.400	1.600
Y	5.100	6.300

Marking



NOTE:
AABXXXG
AA —cycle code
B —Fab code
XXX —Assembly lot code

Revision History

Revision	Date	Major changes
1.0	2022/5/7	Release of formal version
2.0		
3.0		

Disclaimer

Unless otherwise specified in the datasheet, the product is designed and qualified as a standard commercial product and is not intended for use in applications that require extraordinary levels of quality and reliability, such as automotive, aviation/aerospace and life-support devices or systems.

Any and all semiconductor products have certain probability to fail or malfunction, which may result in personal injury, death or property damage. Customer are solely responsible for providing adequate safe measures when design their systems.

CRM reserves the right to improve product design, function and reliability without notice.

单击下面可查看定价，库存，交付和生命周期等信息

[>>CRMICRO\(华润微\)](#)