

FC4150F2M Data Sheet

Rev. A2

Flagchip

Table of Contents

Table of Contents	2
Chapter 1 Introduction	8
1.1 Part Ordering.....	8
1.1.1 Ordering Information.....	8
1.1.2 Orderable Part Number	8
1.2 Marking Rule.....	9
1.3 Abbreviations	9
Chapter 2 Features	12
Chapter 3 General.....	15
3.1 Absolute Maximum Ratings.....	15
3.2 Operation Condition	15
3.3 Thermal Operating Condition	16
3.4 Clock Operating Condition	16
3.5 LVR, LVD, HVD, and POR Operating Requirements	17
3.6 Power Mode Transition	18
3.7 Chip IDD	18
3.8 PMC Internal LDO	19
3.9 ESD Ratings	20
Chapter 4 I/O Parameter.....	21
4.1 IO DC Specification	21
4.2 IO AC Specification.....	22
Chapter 5 Clock Specification	23
5.1 FOSC Specification	23
5.2 SOSC Specification	24
5.3 FIRC96M Specification	24
5.4 SIRC12M Specification.....	24
5.5 SIRC32k Specification.....	25
5.6 PLL0 Specification	25

Chapter 6 Non-Volatile Memory (NVM)	26
6.1 NVM Retention	26
6.2 NVM Program/Erase Time	26
6.3 NVM Max Read Timing	27
Chapter 7 Analog	28
7.1 12-bit SAR ADC Specification	28
7.2 CMP Specification	29
Chapter 8 Peripherals	30
8.1 FCSPI Specification	30
8.2 I2S Specification	36
8.3 ENET Specification	37
8.4 OSPI Specification	40
Chapter 9 Debug Modules	42
9.1 SWD Specification	42
9.2 Trace Block	43
9.3 JTAG Interface	43
Chapter 10 Package	45
10.1 Thermal Data	45
10.2 Package Dimension	45
Chapter 11 Pinout	49
Revision History	71

List of Figures

Figure 1. Ordering information	8
Figure 2. FC4150F2M block diagram.....	12
Figure 3. FC4150F1M_A block diagram.....	12
Figure 4. Crystal connection diagram.....	23
Figure 5. FCSPi master mode timing (SCK_PHA=0)	30
Figure 6. FCSPi master mode timing (SCK_PHA=1)	30
Figure 7. FCSPi slave mode timing (SCK_PHA=0)	31
Figure 8. FCSPi slave mode timing (SCK_PHA=1)	31
Figure 9. I2S master mode timing diagram	36
Figure 10. I2S slave timing diagram	36
Figure 11. MII receive timing diagram	37
Figure 12. MII transmit timing diagram	38
Figure 13. RMIi receive timing diagram	38
Figure 14. RMIi transmit timing diagram.....	38
Figure 15. MDIO timing diagram	39
Figure 16. OSPI SDR/DDR in mode.....	40
Figure 17. OSPI SDR/DDR out mode	40
Figure 18. HyperRAM mode.....	41
Figure 19. SWD clock timing diagram.....	42
Figure 20. SWD data timing diagram	42
Figure 21. Trace block timing diagram.....	43
Figure 22. JTAG clock timing diagram	43
Figure 23. Boundary timing diagram	43
Figure 24. JTAG TAP timing diagram	44
Figure 25. 176LQFP-EP package	46
Figure 26. 144LQFP package	47
Figure 27. 100LQFP package	48
Figure 28. 176LQFP-EP pinout	49

Figure 29. 144LQFP pinout 50

Figure 30. 100LQFP pinout 51

Flagchip

List of Tables

Table 1. Absolute maximum ratings.....	15
Table 2. Operating requirements.....	15
Table 3. Thermal operating condition.....	16
Table 4. Max. functional clock of modules.....	16
Table 5. LVR/LVD/HVD and POR.....	17
Table 6. Power mode transition time.....	18
Table 7. Chip RUN IDD.....	18
Table 8. Chip low power IDD.....	19
Table 9. V25 LDO specification.....	19
Table 10. Core LDO specification.....	19
Table 11. ESD ratings.....	20
Table 12. 3V IO DC specification.....	21
Table 13. 5V IO DC specification.....	21
Table 14. 3V IO AC specification.....	22
Table 15. 5V IO AC specification.....	22
Table 16. FOSC specification.....	23
Table 17. SOSC specification.....	24
Table 18. FIRC96M specification.....	24
Table 19. SIRC12M specification.....	24
Table 20. SIRC32k specification.....	25
Table 21. PLL0 specification.....	25
Table 22. NVM retention specification.....	26
Table 23. FC4150F2M NVM program/erase time.....	26
Table 24. FC4150F1M_A NVM program/erase time.....	26
Table 25. ADC specification.....	28
Table 26. CMP specification.....	29
Table 27. FCSPi 3V specification.....	32
Table 28. FCSPi 5V specification.....	34

Table 29. I2S electrical specification	36
Table 30. MII/RMII electrical specification.....	38
Table 31. MDIO electrical specification	39
Table 32. OSPI timing	40
Table 33. SWD electrical specification.....	42
Table 34. Trace block electrical specification.....	43
Table 35. JTAG electrical specification.....	44
Table 36. Thermal package simulation data.....	45
Table 37. FC4150F2M and FC4150F1M_A pin functions	52

Flagchip

Chapter 1 Introduction

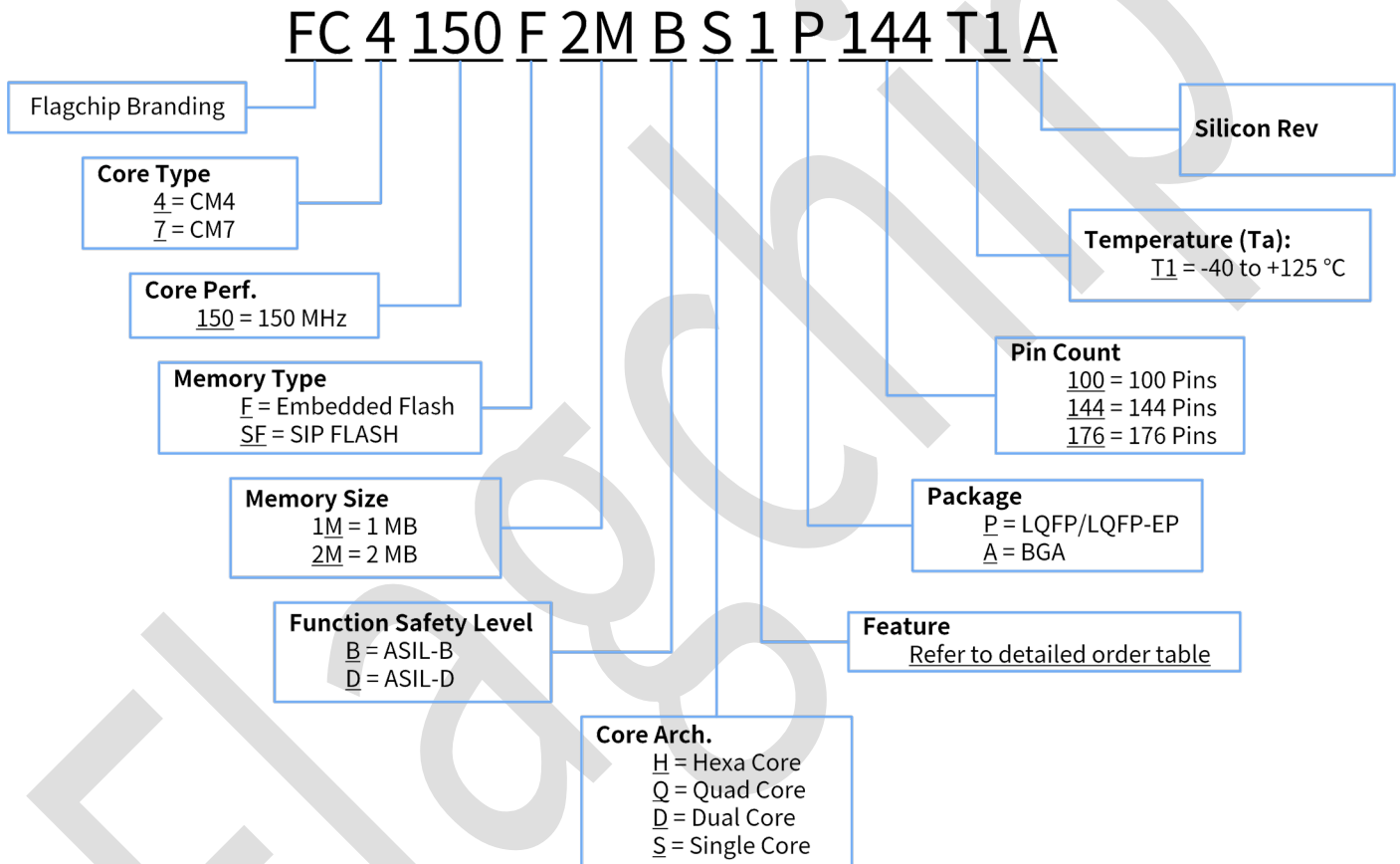
This data sheet provides the ordering information, electrical specifications, package information, and pinout data of the Flagchip FC4150F2M and FC4150F1M_A microcontroller (MCU).

1.1 Part Ordering

1.1.1 Ordering Information

The ordering of the Flagchip MCU follows the rules below. For detailed part information, refer to the Flagchip company.

Figure 1. Ordering information



Note: 1. The technical information for 176LQFP-EP devices in the data sheet is preliminary until this package option achieves qualification.

2. Not all part number combinations are available.

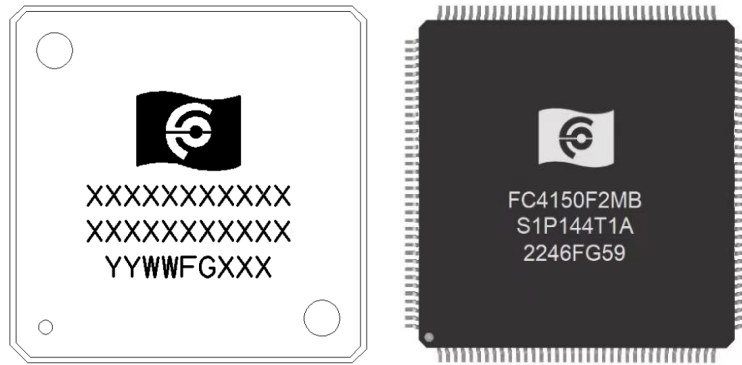
1.1.2 Orderable Part Number

Except the 176LQFP-EP devices, the devices in other packages for FC4150F2M and FC4150F1M_A are AEC-Q100 qualified. The FC4150 series microcontrollers are ASIL B certified according to ISO 26262.

Refer to the attached *FC4150F2M_and_FC4150F1M_A_Orderable_Part_Number_List_A1.xlsx* for a list of standard orderable part numbers.

1.2 Marking Rule

The followings are the schematic diagram and the picture of a FC4150 chip.



Marking rules of the FC4150 family are listed in the table below.

Row	Step	Content	Description	Fixed/Dynamic	Align
1	1	logo (LL006758.LOG)	Logo	Fixed	Center
2	1	XXXXXXXXXX	Part number	Dynamic	Center
3	1	XXXXXXXXXX	Part number	Dynamic	Center
4	1	YYWW	Date code	Dynamic	Left
4	2	FGXX	Lot schedule number	Dynamic	Left
4	3	X	Engineering information	Optional	Left

1.3 Abbreviations

The following abbreviations are used in this document.

No.	Abbreviation	Description
1.	ADC	Analog-to-Digital Converter
2.	AFCB	Advanced Flagchip Bus (APB Bridge)
3.	AONTIMER	Always-on Timer
4.	APB	Advanced Peripheral Bus
5.	AVB	Audio Video Bridging
6.	CAN	Controller Area Network
7.	CBC	Cipher Block Chaining
8.	CGC	Clock Gating Control
9.	CRC	Cyclic Redundancy Check
10.	DAC	Digital-to-Analog Converter
11.	DMA	Direct Memory Access
12.	DP	Debug Port
13.	DSP	Digital Signal Processing
14.	DWT	Data Watchpoint and Trace
15.	ECB	Electronic Codebook Book
16.	ECC	Error Correction Code
17.	ENET	Ethernet
18.	ERM	Error Reporting Module

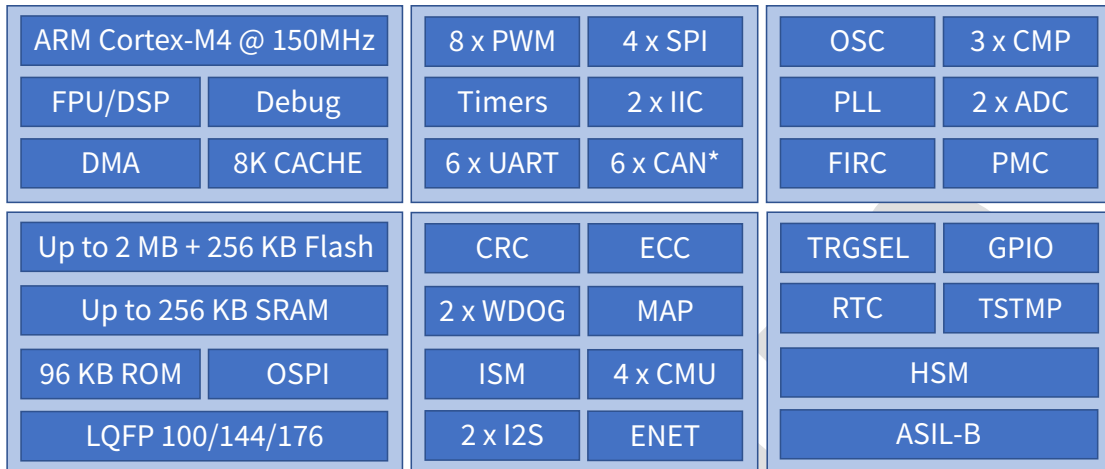
No.	Abbreviation	Description
19.	ESD	Electrostatic Discharge
20.	ETM	Embedded Trace Macrocell
21.	FCIIC	Flagchip (FC) Inter-Integrated Circuit
22.	FCPIT	Flagchip (FC) Programmable Interrupt Timer
23.	FCSPI	Flagchip (FC) Serial Peripheral Interface
24.	FCUART	Flagchip (FC) Universal Asynchronous Receiver Transmitter
25.	FIRC	Fast Internal Reference Clock
26.	FMC	Flash Memory Controller
27.	FOSC	Fast Oscillator
28.	FPB	Flash Patch and Breakpoint
29.	FPM	Full Performance Mode
30.	FPU	Floating Point Unit
31.	FTU	Flexible Timer Unit
32.	FWM	Function Safety Watchdog Monitor
33.	GPIO	General-Purpose Input/Output
34.	HMI	Human-Machine Interface
35.	HSM	Hardware Secure Module
36.	HVD	High-Voltage Detect
37.	I2S	Inter-IC Sound
38.	IIC/I2C	Inter-Integrated Circuit
39.	IRC	Internal Reference Clock
40.	ISM	Interface Safety Monitor
41.	ITM	Instrumentation Trace Macrocell
42.	LDO	Low Dropout
43.	LIN	Local Interconnect Network
44.	LVD	Low-Voltage Detect
45.	LVR	Low-Voltage Reset
46.	MAP	Memory Access Protection
47.	MII	Media Independent Interface
48.	MPU	Memory Protection Unit
49.	NMI	Non-maskable Interrupt
50.	NVM	Non-Volatile Memory
51.	OSC	Oscillator
52.	OSPI	Octal Serial Peripheral Interface
53.	PCC	Peripheral Clock Controller
54.	PIT	Programmable Interrupt Timer
55.	PLL	Phase-Locked Loop
56.	PMC	Power Management Controller
57.	POR	Power-on Reset
58.	PWM	Pulse Width Modulation
59.	RCM	Reset Control Module

No.	Abbreviation	Description
60.	RMII	Reduced Media Independent Interface
61.	RPM	Reduce Power Mode
62.	RTC	Real-Time Clock
63.	SAR	Successive Approximation
64.	SCG	System Clock Generator
65.	SIRC	Slow Internal Reference Clock
66.	SOSC	Slow Oscillator
67.	SPI	Serial Peripheral Interface
68.	SWD	Serial Wire Debug
69.	SWJ-DP	Serial Wire/JTAG Debug Port
70.	TAP	Test Access Port
71.	TCM	Tightly-Coupled Memory
72.	TPIU	Trace Port Interface Unit
73.	TRGSEL	Trigger Select
74.	TSTMP	Timer Stamp
75.	UART	Universal Asynchronous Receiver and Transmitter
76.	VCO	Voltage-Controlled Oscillator
77.	WDOG	Watchdog
78.	WKU	Wake-up Unit

Chapter 2 Features

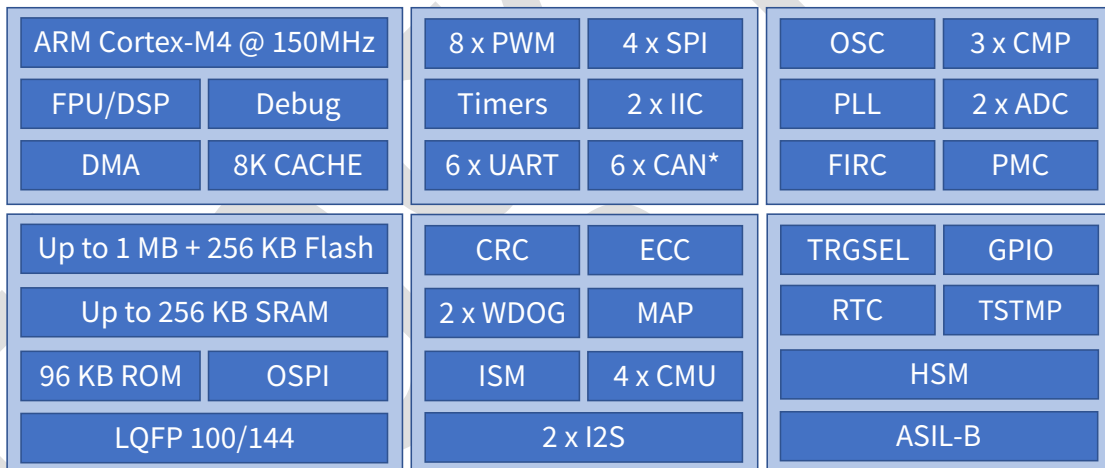
This chapter summarizes the FC4150F2M features. For detailed information, refer to the FC4150 Reference Manual.

Figure 2. FC4150F2M block diagram



* Optional CAN FD support

Figure 3. FC4150F1M_A block diagram



* Optional CAN FD support

Note: Not all features in this block diagram are available on all parts, refer to the Reference Manual for details.

- **Operating Environment**
 - Voltage range: 3.0 V to 5.5 V
 - Ambient temperature (T_A) range: - 40°C to + 125°C; junction temperature (T_J) range: - 40°C to + 150°C
- **Arm Cortex-M4F Core**
 - 150 MHz frequency with 2.66 Dhrystone MIPS per MHz
 - Armv7 Architecture and Thumb-2 ISA
 - Digital Signal Processing (DSP) instruction
 - Single-Precision Floating Point Unit (FPU)
 - Support Memory Protection Unit (MPU) with 8 regions
- **16-channel Direct Memory Access (DMA) with selected DMA source**
- **Clock Sources**

- 16 - 48 MHz Fast Oscillator (FOSC) with up to 50 MHz DC external input clock in bypass mode
- 32 kHz Slow Oscillator (SOSC)
- 96 MHz Fast Internal RC Oscillator (FIRC96M)
- 12 MHz Slow Internal RC Oscillator (SIRC12M)
- 32 kHz Slow Internal RC Oscillator (SIRC32k)
- Up to 200 MHz Phased Lock Loop (PLL0) with reference from FIRC48M or FOSC
- **Power Management**
 - Four power modes: RUN, WAIT, STOP and Standby. Optional 64 KB RAM retention in standby mode
- **Memory**
 - Up to 2 MB program flash memory with Error Correction Code (ECC)
 - Up to 256 KB data flash memory with ECC
 - Up to 256 KB SRAM with ECC
 - 8 KB instruction cache for Flash
 - Octal Serial Peripheral Interface (OSPI) with up to 50 MHz DDR support (Refer to [Table 28. OSPI timing](#) in Section 8.4 OSPI Electrical Specification for details.)
 - 96 KB ROM with CM4 core self-test/Flash program & erase/ Hardware Secure Module (HSM) APIs
- **Analog**
 - Up to two 12-bit Successive Approximation (SAR) Analog-to-Digital Converters (ADCs) with up to 32 channel analog inputs per module
 - Up to three Analog Comparators (CMPs) with internal 8-bit Digital-to-Analog Converter (DAC)
- **Debug Functionality**
 - Serial Wire/JTAG Debug Port (SWJ-DP) combines
 - Data Watchpoint and Trace (DWT)
 - Instrumentation Trace Macrocell (ITM)
 - Embedded Trace Macrocell (ETM)
 - Trace Port Interface Unit (TPIU)
 - Flash Patch and Breakpoint (FPB) Unit
 - JTAG Test Access Port (TAP) and boundary scan support
- **Human-Machine Interface (HMI)**
 - Up to 160 GPIO pins with interrupt support
 - Non-maskable Interrupt (NMI)
 - GPIO input/output interface
- **Communications Interfaces**
 - Up to six FC Universal Asynchronous Receiver/Transmitter (FCUART) modules with LIN support
 - Up to four FC Serial Peripheral Interface (FCSPI) modules, support 1/2/4 data lines and master/slave mode
 - Up to two FC Inter-Integrated Circuit (FCIIC) modules
 - Up to six FLEXCAN modules with CAN FD (optional) and PNET support on FLEXCAN0-2
 - One 10/100 Mbps Ethernet with IEEE1588 and AVB
 - Two Inter-IC Sound (I2S) modules
 - Four Trigger Selects (TRGSELs) for on chip bus connection
 - Lookup Unit (LU) module with 4 lookup tables
- **Safety and Security**
 - Hardware Secure Module (HSM) with crypto algorithms including AES/SM4/ECC/RSA/SHA/SM3/SM2/SM9
 - CCM/GCM/ECB/CTR/CBC etc. mode

- Support random number generation and pseudo random number generation
- Key import/export management
- ECC on flash and SRAM memories
- Memory Access Protection (MAP) on system SRAM
- Peripheral Access Protection on APB bridge (AFCB)
- Cyclic Redundancy Check (CRC) module
- Up to two Internal watchdogs (WDOG) with window function
- FunSa Watchdog Monitor (FWM) module
- Interface Safety Monitor (ISM) module to monitor the critical signals' delay/period/duty etc.
- CM4 core self-test API in ROM code
- **Timers**
 - Up to eight Flexible Timer Unit (FTU) modules with IC/OC/PWM function
 - One Always-on Timer (AONTIMER) with standby wake up capability
 - Two Programmable Timers (PTIMER)
 - One FC Programmable Interrupt Timer (FCPIT) with 4 channels
 - One Real-Time Clock (RTC)
 - One 56-bit Timer Stamp (TSTMP) with four 32-bit compare channels. The TSTMP1 runs at Core clock
- **Package:** 100LQFP, 144LQFP and 176LQFP-EP package options
- **Qualification:**
 - ASIL B certified according to ISO 26262
 - AEC-Q100/Q006 Grade 1 (-40°C to 125°C)

Chapter 3 General

3.1 Absolute Maximum Ratings

The table below lists the maximum allowed conditions for the chip. To avoid the chip damage, the user needs to make sure the conditions are met.

Table 1. Absolute maximum ratings

Symbol	Description	Min.	Max.	Unit
V _{DD_HV}	3.0 V - 5.5 V input supply voltage	-0.3	6.0 ¹	V
V _{REFH}	3.3 V - 5.0 V high reference voltage	-0.3	6.0 ¹	V
I _{INJPAD_DC_ABS}	Continuous DC input current (positive / negative) that can be injected into an I/O pin	-	3	mA
V _{IN_DC}	Continuous DC Voltage on any I/O pin with respect to V _{SS}	-0.8	6.0 ¹	V
I _{INJSUM_DC_ABS}	Sum of injected currents on all the pins (Continuous DC limit, positive / negative)	-	25 ²	mA
T _{ramp_MCU}	MCU supply ramp rate	-	100 V/ms	-
T _A	Ambient temperature	-40	125	°C
T _{STG}	Storage temperature	-55	165	°C
V _{IN_TRANSIENT}	Transient overshoot voltage allowed on I/O pin beyond V _{IN_DC} limit	-	6.8	V

1. Operation with the 6.0 V maximum is allowed for 10 hours over lifetime.
2. The maximum value is based on V_{DD_HV_A} = V_{DD_HV_B} = 5V condition and continuous pins DC injection current includes sum of injection currents of 16 continuous pins.

Note: For inject current, the user needs to make sure that it won't cause issue if the inject current is above the chip self-power consumption (like standby/stop mode). Otherwise, it may cause damage.

3.2 Operation Condition

The table below lists the chip operation condition. To meet the design specifications, these conditions need to be met.

Note: V_{DD_HV} means the supply such as V_{DD_HV_A}/V_{DD_HV_B}.

Table 2. Operating requirements

Symbol	Description	Min.	Max.	Unit
V _{DD_HV}	Supply voltage	3.0	5.5	V
V _{DD_OFF}	Voltage allowed to be developed on V _{DD_HVA} pin when it is not powered from any external power supply source.	0	0.1	V
V _{DDA}	Analog supply voltage	3.0	5.5	V
V _{DD_HV} - V _{DDA}	V _{DD_HV} to V _{DDA} differential voltage	-0.1	0.1	V
V _{REFH}	ADC reference voltage high	3.0	V _{DDA} + 0.1	V
V _{REFL}	ADC reference voltage low	-0.1	0.1	V
I _{INJPAD_DC_OP}	Continuous DC input current (positive / negative) that can be injected into an I/O pin	-1	+1	mA

Table 2. Operating requirements (continued)

Symbol	Description	Min.	Max.	Unit
I _{INJSUM_DC_OP}	Continuous total DC input current that can be injected across all I/O pins	-	5	mA
T _{pulse}	Reset/NMI input analog filter pulse width	42	-	ns

3.3 Thermal Operating Condition

Table 3. Thermal operating condition

Symbol	Description	Min.	Typ.	Max.	Unit	Notes
T _A	Ambient temperature	-40	-	125	°C	
T _J	Junction temperature	-40	-	150	°C	

3.4 Clock Operating Condition

The table below lists the maximum functional clocks of modules. For the IO-related max clock frequency, refer to each IPs electrical specification. For the SCG DIVH/M/L output, it should be not above the 150 MHz/75 MHz/37.5 MHz range.

Table 4. Max. functional clock of modules

Module/Peripheral	Max. Functional Clock (for STA)	Notes
CPU & System Modules		
CM4	150 MHz	
DMA	150 MHz	
FWM	75 MHz	
WDOGx	75 MHz	
WKU	75 MHz	
RCM	75 MHz	
SCG	-	
PCC	-	
TRGSELx	75 MHz	
Memory Modules		
ROM	150 MHz	
TCM	150 MHz	
FMC	150 MHz	
FC	150 MHz	
OSPI	50 MHz	
Security Modules		
CRC	150 MHz	
HSM	75 MHz	
Communication Modules		
FCSPiX	75 MHz	
FCUARTx	75 MHz	

Table 4. Max functional clock of modules (continued)

Module/Peripheral	Max. Functional Clock (for STA)	Notes
FCIICx	75 MHz	
FLEXCAN0-5	150 MHz	
ENET	25 MHz MII, 50 MHz RMII, 2.5 MHz MDC	
Timer Modules		
AONTIMERO	75 MHz	
FCPIT0	75 MHz	
FTU0-7	150 MHz	
TSTMP1	150 MHz	
RTC	32 kHz	
PTIMER0-1	150 MHz	
HMI Modules		
GPIOx	150 MHz	
PORTx	75 MHz	
Analog Modules		
ADCx	30 MHz	
CMPx	75 MHz	
PMC	75 MHz	

3.5 LVR, LVD, HVD, and POR Operating Requirements

The chip supports monitors including Power-on Reset (POR)/ Low-Voltage Reset (LVR)/ Low-Voltage Detect (LVD) on the VDD_HV supply.

Table 5. LVR/LVD/HVD and POR

VDD_HV_A/B supply HVD, LVD and POR Operating Ratings						
Symbol	Description	Min.	Typ.	Max.	Unit	Notes
V _{POR}	POR re-arm voltage	1.1	1.6	2.1	V	
V _{LVR_VDD_HV}	LVR on V _{DD_HV_A/B}	2.75	2.85	2.95	V	
V _{HVD_VDD_HV}	HVD on V _{DD_HV_A/B}	5.7	5.85	6	V	
V _{LVD_VDD_HV}	LVD on V _{DD_HV_A/B}	4.2	4.35	4.5	V	
V _{HYS}	Hysteresis Voltage	-	0.04	0.1	V	
V _{BG}	Bandgap voltage reference voltage	1.164	1.2	1.236	V	

3.6 Power Mode Transition

The table below lists the different power mode transition time.

Table 6. Power mode transition time

Symbol	Description	Min.	Typ.	Max.	Unit
t _{POR}	After a POR event, the amount of time from the point VDD reaches 2.7 V to execution of the first instruction across the operating temperature range of the chip.	-	200	-	μs
t _{STBtoR}	Standby → RUN (First code)	-	130	-	μs
t _{STtoR}	STOP → RUN (FIRC and SIRC are enabled in Stop mode)	-	3	-	μs
t _{RtoST}	RUN → STOP	-	5	-	μs
t _{RtoSTB}	RUN → Standby	-	12	-	μs
t _{REStoR}	Pin reset → RUN (First code)	-	2	-	μs

3.7 Chip IDD

The chip supports four power modes: RUN/WAIT/STOP/Standby. During standby mode, the V25 Low Dropout (LDO) and SIRC12M/FOSC etc. can be optionally on. Both code RAM and data RAM can optionally retain 32 KB SRAM during standby mode. Refer to the Reference Manual for detailed settings.

The table below lists the chip RUN IDD current. The peripheral enabled/disabled here means enabling/disabling the peripherals' clock gating control (CGC).

Table 7. Chip RUN IDD

Symbol	Description	Min.	Typ. ¹	Max.	Unit	Notes
I _{dd_active}	Active mode current - all peripherals disabled, while1, 150 MHz/75 MHz for Core/Bus, Cache enable, 25°C	-	24.6	29.3	mA	
	Active mode current - all peripherals enabled and clock switch 150 MHz PLL0 output, while1, 150 MHz/75 MHz for Core/Bus, Cache enable, 25°C	-	41.8	46.5	mA	
	Active mode current - all peripherals enabled and clock switch 150 MHz PLL0 output, while1, 150 MHz/75 MHz for Core/Bus, Cache enable, 125°C	-	51.9	106.1	mA	
I _{dd_wait}	Wait mode – all peripherals enable and clock switch 150 MHz PLL0 output, 25°C	-	32.3	37.0	mA	
	Wait mode – all peripherals enable and clock switch 150 MHz PLL0 output, 105°C	-	37.3	91.5	mA	
	Wait mode – all peripherals enable and clock switch 150 MHz PLL0 output, 125°C	-	41.6	95.8	mA	

1. Typical value indicates the typical silicon process and the average current values at the nominal internally regulated V11 supply voltage, VDD_HV_A = 5.0 V, and VDD_HV_B = 5.0 V.

Table 8. Chip low power IDD

Symbol	Description	Min.	Typ. ¹	Max.	Unit	Notes
I _{dd_stop}	STOP Mode, 25°C	-	2.3	4.2	mA	
	STOP Mode, 105°C	-	6.3	22.6	mA	
	STOP Mode, 125°C	-	9.8	37.3	mA	
I _{dd_standby}	Standby Mode, all 64K RAM retention, 25°C	-	70.3	213.1	μA	
	Standby Mode, only 32K RAM retention, 25°C	-	63	205.8	μA	
	Standby Mode, no RAM retention, 25°C	-	56	198.8	μA	
	Standby Mode, no RAM retention, 125°C	-	499.7	4133.2	μA	
	Standby Mode, no RAM retention, SIRC12M Enable, 25°C	-	162.0	304.8	μA	
	Standby Mode, no RAM retention, SIRC32K Enable, 25°C	-	57.3	200.1	μA	

1. Typical value indicates the typical silicon process and the average current values at the nominal internally regulated V11 supply voltage, VDD_HV_A = 5.0 V, and VDD_HV_B = 5.0 V.

3.8 PMC Internal LDO

The chip contains two LDO supply outputs: V25 and V11. Both V25 and V11 support the Full Performance Mode (FPM) and Reduce Power Mode (RPM). External cap needs to be put on the V25/V11 pin to make sure LDO function works as expected.

Table 9. V25 LDO specification

Symbol	Description	Min.	Typ.	Max.	Unit	Notes
V _{DD_HV_A}	V25 input supply voltage	3	-	5.5	V	
V25	V25 regulator output voltage	2.25	-	2.75	V	
C _{out}	External output capacitor	-	220	-	nF	

Table 10. Core LDO specification

Symbol	Description	Min.	Typ.	Max.	Unit	Notes
V _{DD_HV_A}	V11 input supply voltage	3	-	5.5	V	
V11	V11 regulator output voltage	1.06	-	1.21	V	
C _{out}	External output capacitor	-	1.1	2.2	μF	

3.9 ESD Ratings

The Electrostatic Discharge (ESD) result follows the industry test standard.

Table 11. ESD ratings

Symbol	Description	Min.	Max.	Unit	Notes	
V_{HBM}	Electrostatic discharge voltage, human body model (HBM)	-2000	2000	V	1, 2, 3	
V_{CDM}	Electrostatic discharge voltage, charged-device model (CDM)	All pins except the corner pins	-500	500	V	1, 3, 4
		Corner pins only	-750	750	V	
I_{LAT}	Latch-up current at ambient temperature of 125°C	-100	100	mA	1, 3, 5	

1. Device failure is defined as the situation where the device fails to meet the specification requirements after being exposed to ESD pulses.
2. This parameter is tested in compliance with AEC-Q100-002.
3. All ESD tests comply with AEC-Q100 Stress Test Qualification for Automotive Grade Integrated Circuits.
4. This parameter is tested in compliance with AEC-Q100-011.
5. This parameter is tested in compliance with AEC-Q100-004.

Chapter 4 I/O Parameter

4.1 IO DC Specification

The IO can work with supplies from 3.0 V to 5.5 V. The tables below list specifications for the supplies.

Table 12. 3V IO DC specification

Symbol	Description	Min.	Typ.	Max.	Unit	Notes
V _{IH}	Input high voltage	0.65*VDD_IO	-	-	V	
V _{IL}	Input low voltage	-	-	0.35*VDD_IO	V	
V _{HYS}	Input hysteresis	0.07*VDD_IO	-	-	V	
V _{oh_normal}	I/O current source capability with I _{oh} =4mA	VDD_IO - 0.68	-	-	V	
V _{ol_normal}	I/O current sink capability with I _{ol} =4mA	-	-	0.712	V	
V _{oh_fast}	I/O current source capability with I _{oh} =4mA and DSE=0	VDD_IO - 0.78	-	-	V	
V _{ol_fast}	I/O current sink capability with I _{ol} =4mA and DSE=0	-	-	0.751	V	
V _{oh_fast}	I/O current source capability with I _{oh} =8mA and DSE=1	VDD_IO - 0.78	-	-	V	
V _{ol_fast}	I/O current sink capability with I _{ol} =8mA and DSE=1	-	-	0.751	V	
I _{PU}	Internal pullup current (R _{load} =0, output tie to VSS)	65	-	124	μA	
I _{PD}	Internal pulldown current (R _{load} =0, output tie to VDD_IO)	68	-	133	μA	

Table 13. 5V IO DC specification

Symbol	Description	Min.	Typ.	Max.	Unit	Notes
V _{IH}	Input high voltage	0.65*VDD_IO	-	-	V	
V _{IL}	Input low voltage	-	-	0.35*VDD_IO	V	
V _{HYS}	Input hysteresis	0.07*VDD_IO	-	-	V	
V _{oh_normal}	I/O current source capability with I _{oh} =4mA	VDD_IO - 0.68	-	-	V	
V _{ol_normal}	I/O current sink capability with I _{ol} =4mA	-	-	0.46	V	
V _{oh_fast}	I/O current source capability with I _{oh} =4mA and DSE=0	VDD_IO - 0.5	-	-	V	
V _{ol_fast}	I/O current sink capability with I _{ol} = 4mA and DSE = 0	-	-	0.444	V	

Table 13. 5V IO DC specification (continued)

Symbol	Description	Min.	Typ.	Max.	Unit	Notes
V _{oh_fast}	I/O current source capability with I _{oh} = 8mA and DSE = 1	VDD_IO - 0.5	-	-	V	
V _{ol_fast}	I/O current sink capability with I _{ol} = 8mA and DSE = 1	-	-	0.444	V	
I _{pu}	Internal pullup current (Rload = 0, output tie to VSS)	107	-	213	μA	
I _{pd}	Internal pulldown current (Rload = 0, output tie to VDD_IO)	110	-	210	μA	

4.2 IO AC Specification

The below is the IO AC specification, wherein the minimum value is based on 3.6 V/5.5 V/150°C condition and the maximum value is based on 3.0 V/4.5 V/-40°C condition. **Note:** The specification is based on simulation data.

Table 14. 3V IO AC specification

Symbol	SRE	DSE	Rise Time (ns)		Fall Time (ns)		Capacitance (pF)
			Min.	Max.	Min.	Max.	
t _{RNormal}	0		2.12	8.82	2.3	8.64	25, 20%-80% r/f
t _{RNormal}	1		3.3	10.98	3.1	10.32	25, 20%-80% r/f
t _{RFast}		1	1.52	4.63	1.39	4.53	25, 20%-80% r/f
t _{RFast}		0	2.77	8.04	2.75	8.39	25, 20%-80% r/f

Table 15. 5V IO AC specification

Symbol	SRE	DSE	Rise Time (ns)		Fall Time (ns)		Capacitance (pF)
			Min.	Max.	Min.	Max.	
t _{RNormal}	0		2.16	6.41	2.15	6.08	25, 20%-80% r/f
t _{RNormal}	1		2.67	7.82	2.43	7.19	25, 20%-80% r/f
t _{RFast}		1	1.14	3.18	1.11	3.09	25, 20%-80% r/f
t _{RFast}		0	2.16	6.7	2.31	6.06	25, 20%-80% r/f

Chapter 5 Clock Specification

5.1 FOSC Specification

The Fast Oscillator (FOSC) supports the range of 16 - 48 MHz. To avoid the startup noise impact, software should wait enough time before using the clock. The FOSC can keep enabled during standby/stop mode.

Figure 4. Crystal connection diagram

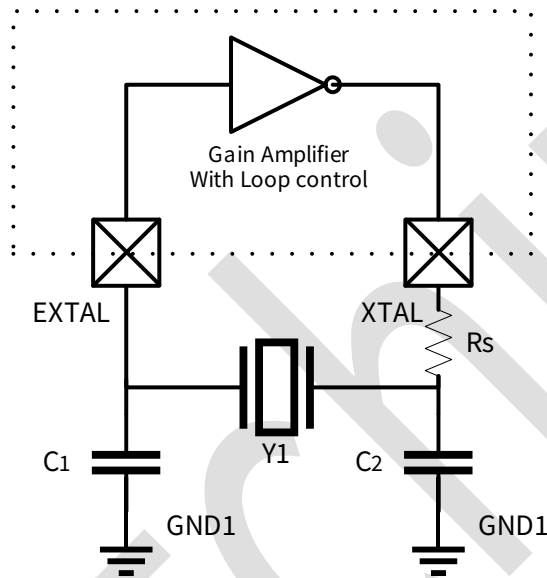


Table 16. FOSC specification

Symbol	Description	Min.	Typ.	Max.	Unit	Notes
f_{osc}	Oscillator crystal or resonator frequency	16	40	48	MHz	
T_{st_osc}	Startup time	-	600	-	μs	
I_{dd_osc}	Current consumption	-	1200	-	μA	
GM	Gain Amplifier transconductance	11.07	-	26.24	mA/V	Select max GM setting

For crystal selection, usually require $g_m > 5 \cdot g_{m_{crit}}$.

- Formula $gain_{margin} = g_m / g_{m_{crit}}$, where:
 - g_m is the oscillator transconductance specified in the data sheet. Note that the oscillator transconductance is in the range of a dozen of mA/V.
 - $g_{m_{crit}}$ is defined as the minimal transconductance of an oscillator required to maintain a stable oscillation when it is a part of the oscillation loop for which this parameter is relevant.
 - $g_{m_{crit}}$ is computed from oscillation-loop passive components parameters (R_s is 0 here).
- $g_{m_{crit}} = 4 \times ESR (2\pi F)^2 \times (C_0 + C_L)^2$, where:
 - ESR is the equivalent series resistance.
 - C_0 is the crystal shunt capacitance.
 - C_L is the crystal nominal load capacitance, $C_L = C_s + [C_1 \cdot C_2 / (C_1 + C_2)]$ (Note: C_1 should be equal to C_2).
 - F is the crystal nominal oscillation frequency.

5.2 SOSC Specification

The Slow Oscillator (SOSC) supports the 32.768 kHz crystal. To avoid the startup noise impact, software should wait enough time before using the clock. The SOSC will keep enabled during system reset. Only POR/LVD will reset the SOSC.

Table 17. SOSC specification

Symbol	Description	Min.	Typ.	Max.	Unit	Notes
f_{osc32k}	Oscillator crystal or resonator frequency	-	32.768	-	kHz	
T_{st_osc32k}	Startup time	-	1	-	s	
I_{dd_osc32k}	Current consumption	-	1.8	-	μ A	
GM	Gain Amplifier transconductance	26	-	54.5	μ A/V	

5.3 FIRC96M Specification

The FIRC96M is the default system clock after reset. FIRC96M provides two clock sources, one is 96 MHz and the other is 48 MHz. The 96 MHz clock can be selected as the system clock. The 48 MHz clock can be selected as the PLL reference clock and Flash program/erase clock. Software needs to make sure FIRC is enabled and 48 MHz clock output is enabled before a flash program/erase operation or selecting the FIRC as the PLL reference clock. After reset, the FIRC is enabled and both 96 MHz and 48 MHz clock output are enabled.

Table 18. FIRC96M specification

Symbol	Description	Min.	Typ.	Max.	Unit	Notes
$f_{firc96m}$	firc96m clock frequency range	-	96	-	MHz	
$\Delta f_{firc96m}$	Frequency Deviation with 1T trim	-	-	± 4	$\%f_{firc96m}$	
$T_{st_firc96m}$	Startup time (<20% accuracy), from disable	-	2.4	-	μ s	
	Startup time (<1% accuracy)	-	30	-	μ s	

5.4 SIRC12M Specification

The SIRC12M is used for system low power mode entry. SIRC12M can keep enabled during standby mode. During RUN mode, SIRC12M is always enabled. Clock sources of WDOGx etc. can be selected from SIRC12M divider outputs.

Table 19. SIRC12M specification

Symbol	Description	Min.	Typ.	Max.	Unit	Notes
$f_{sirc12m}$	SIRC12M clock frequency	-	12	-	MHz	
$\Delta f_{sirc12m}$	Frequency Deviation with 1T trim	-	-	± 5	$\%f_{sirc12m}$	
$T_{st_sirc12m}$	Startup time from POR	-	3	-	μ s	

5.5 SIRC32k Specification

The SIRC32k can be used for low power wakeup source. It can keep enabled during standby mode.

Table 20. SIRC32k specification

Symbol	Description	Min.	Typ.	Max.	Unit	Notes
f_{sirc32k}	SIRC32k clock frequency	-	32	-	kHz	
$\Delta f_{\text{sirc32k}}$	Frequency Deviation with 1T trim	-	-	± 5	$\%f_{\text{sirc32k}}$	
$T_{\text{st_sirc32k}}$	Startup time from POR	-	-	20	μs	

5.6 PLL0 Specification

The PLL0 can be used for the system clock. The PLL reference clock can select from FIRC96M (48 MHz output) or FOSC. Refer to the *Reference Manual* for detailed settings.

Table 21. PLL0 specification

Symbol	Description	Min.	Typ.	Max.	Unit	Notes
$f_{\text{pll_ref}}$	PLL reference frequency range	2	-	16	MHz	Reference clock after pre-divider
$f_{\text{pll_out}}$	PLL output frequency	90	-	200	MHz	VCO clock is 2x of this data
Duty	Duty cycle	45	-	55	%	
I_{pll}	PLL operating current	-	1.5	-	mA	
T_{pll}	Frequency 1% lock time from standby mode	-	120	-	μs	Polling lock bit by software, and assume reference clock is ready
	Frequency 1% lock time from disabled mode	-	30	-	μs	Polling lock bit by software, and assume reference clock is ready

Chapter 6 Non-Volatile Memory (NVM)

6.1 NVM Retention

Table 22. NVM retention specification

Symbol	Description	Condition	Min.	Typ.	Max.	Unit	Notes
Program/Erase (P/E) cycles	Number of program/erase cycles per block for 256 KB blocks using Sector Erase	-	100K	-	-	Cycles	
	Number of program/erase cycles per block for 1 MB and 2 MB blocks using Sector Erase	-	1K	-	-	Cycles	
Data Retention	Minimum data retention	Blocks with 0 - 1K P/E cycles	20	-	-	Years	
		Blocks with 100K P/E cycles	10	-	-	Years	

6.2 NVM Program/Erase Time

Table 23. FC4150F2M NVM program/erase time

Symbol	Description	Min.	Typ.	Max.	Unit	Notes
T _{2wpgm}	2 words (64 bits) program time	-	108	-	μs	
T _{8wpgm}	8 words (256 bits) program time	-	207	-	μs	
T _{32wpgm}	32 words (1024 bits) program time	-	367	-	μs	
T _{8kpgm}	8K bytes sector program time	-	23	-	ms	
T _{8kers}	8K bytes sector erase time	-	3.2	-	ms	
T _{256kers}	256K block erase time	-	20.4	-	ms	
T _{2mers}	2M block erase time	-	29.8	-	ms	

Table 24. FC4150F1M_A NVM program/erase time

Symbol	Description	Min.	Typ.	Max.	Unit	Notes
T _{2wpgm}	2 words (64 bits) program time	-	108	-	μs	
T _{8wpgm}	8 words (256 bits) program time	-	207	-	μs	
T _{32wpgm}	32 words (1024 bits) program time	-	367	-	μs	
T _{8kpgm}	8K bytes sector program time	-	23	-	ms	
T _{8kers}	8K bytes sector erase time	-	3.2	-	ms	
T _{256kers}	256K block erase time	-	20.4	-	ms	
T _{1mers}	1M block erase time	-	29.8	-	ms	

Note: The program/erase time will be influenced by temperature. The typical values here are measured at the beginning of the chip lifecycle and at the temperature of 25 °C.

6.3 NVM Max Read Timing

For FC4150F2M and FC4150F1M_A, the maximum NVM read frequency is 30 MHz.

If system is configured as 150 MHz, the NVM read wait cycle needs to be set to 5 for FC4150F2M and FC4150F1M_A.

Flagchip

Chapter 7 Analog

7.1 12-bit SAR ADC Specification

The chip supports up to two 12-bit Successive Approximation (SAR) Analog-to-Digital Converters (ADCs). The specification below is based on minimum chip activity, and the external VRH is used. The below is the ADC specification.

Table 25. ADC specification

Symbol	Description	Min.	Typ. ¹	Max.	Unit	Notes
V _{DDA}	ADC analog supply	3	-	5.5	V	
V _{SSA}	ADC analog ground	-0.1	0	0.1	V	
V _{REFH}	ADC reference high	3	-	5.5	V	<=V _{DDA} 2
V _{REFL}	ADC reference low	-0.1	0	0.1	V	2
V _{ADIN}	ADC input	V _{REFL}	-	V _{REFH}	V	
C _{ADIN}	ADC input capacitance	-	6.4	-	pF	
R _{ADIN}	ADC input resistance	-	1.5	-	K Ω	
R _{AS}	Input source resistance	-	1	-	K Ω	
TUE	Total unadjusted error - Single	-	± 4	± 8	LSB	3
	Total unadjusted error - Differential	-	± 2	± 4	LSB	
E _Q	Quantization error	-	± 1	-	LSB	
ENOB	Effective number of bits with 1MSPS@12bit mode	-	10.5	-	bits	If VDD is < 4.5 V, the typical value is 10 bits.
SINAD	Signal-to-noise plus distortion	-	ENOB*6.02 + 1.76	-	dB	@1kHz
F _{ADCK}	ADC conversion clock Frequency	6	-	30	MHz	
I _{dd_adc}	Supply current, single mode on V _{REFH}	-	0.7	-	mA	
	Supply current, single mode on V _{DDA}	-	1.75	-	mA	
T _{SU}	Start-up time	-	5	-	μ s	
T _{SMP}	Sample time	4/(F _{ADCK})	-	257/(F _{ADCK})	-	
C _{SMP}	Sample cycles	4	-	257	cycles	
C _{CONV}	Conversion cycles	-	14	-	cycles	
	Conversion rate	-	-	1.6	MS/s	4

1. Typical values assume V_{REFH} = V_{DDA}, Temp = 25 °C, ADC clock = 30 MHz, source impedance = 20 Ω , and input filter capacitor = 10 nF unless otherwise stated. Typical values are used for reference only, not tested in production.
2. For packages without dedicated V_{REFH} and V_{REFL} pins, V_{REFH} is internally tied to V_{DDA}, and V_{REFL} is internally tied to V_{SSA}.
3. There are dead zones when signals near V_{REFH} and V_{REFL}.
4. Max. Conversion Rate = Max. ADC Clock Frequency / (Sample Cycles + Conversion Cycles). Note: Rounding down to the nearest tenth.
5. Appropriate decoupling capacitors to be used to filter noises on the supplies.

6. VSS and VREFL should be shorted on PCB design.
7. Above specifications are for direct channels which are based on 12-bit resolution. Additional mux channels performance may be degraded.
8. The ADC has a dead zone when input is close to VREFL or VREFH. The results here are obtained after calibration and removing the impact of this effect.

Note: Due to triple bonding in lower pin packages, degradation might be seen in ADC parameters.

7.2 CMP Specification

The chip supports high-speed (HS) and low-power (LP) mode. The CMPx can work in standby mode.

Table 26. CMP specification

Symbol	Description	Min.	Typ.	Max.	Unit
I _{dd_cmp}	CMP operating current with HS mode	-	130	-	μA
	CMP operating current with LP mode	-	6	-	μA
V _{input}	Analog input voltage	0.1	-	V _{DDA} - 0.1	V
V _{input_offset}	Analog input offset voltage with HS mode	-	±2	40	mV
	Analog input offset voltage with LP mode	-	±4	40	mV
HYS	Analog comparator hysteresis:	-	-	-	-
	Hyst = 00	-	0	-	mV
	Hyst = 01	-	15	-	mV
	Hyst = 10	-	30	-	mV
	Hyst = 11	-	45	-	mV
T _{init}	Initialization delay	-	-	30	μs
T _{prop}	Propagation delay, 100 mV over drive, supply > 3.0 V (HS mode)	-	50	200	ns
	Propagation delay, 100 mV over drive, supply > 3.0 V (LP mode)	-	1.6	5	μs
V _{idd_dac}	8-bit DAC current adder	-	10	-	μA
INL	8-bit DAC integral non-linearity	-	±1	±3	LSB
DNL	8-bit DAC differential non-linearity	-	±0.5	±1	LSB

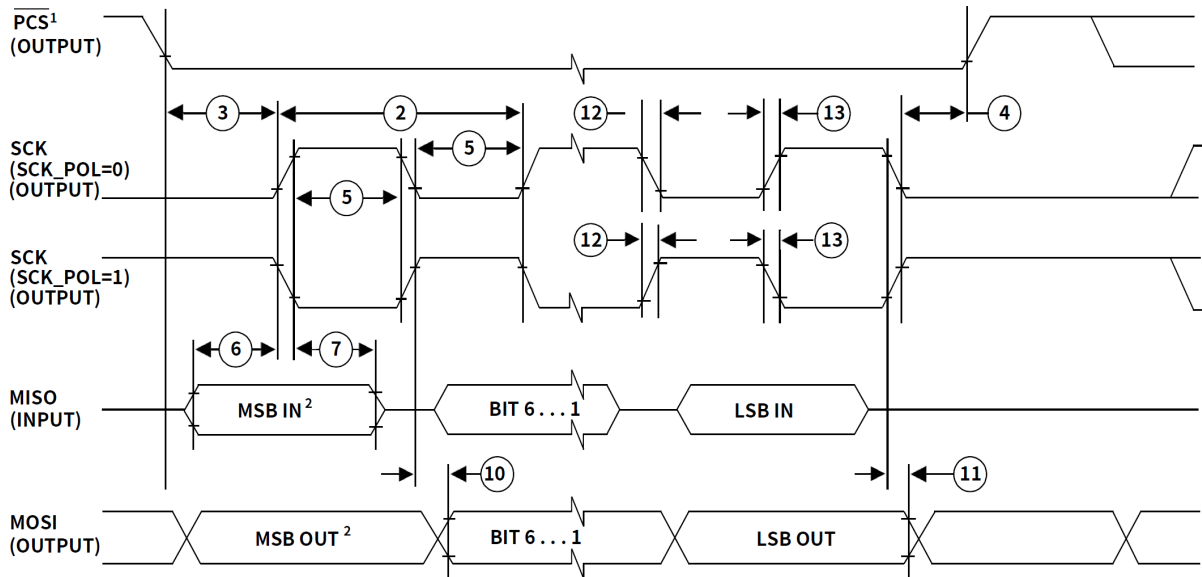
Chapter 8 Peripherals

All peripherals' timings shown below are based on 25 pF (OSPI/ENET are 15 pF) external loading and input transitions of 1 ns. For normal pad, the SRE is set to 0; for fast pad, the DSE is set to 1. The rise/fall timing is based on 20% VDD_HV to 80% VDD_HV thresholds. Besides, the delay time is based on 50% VDD_HV to 50% VDD_HV thresholds.

8.1 FCSPI Specification

The FCSPI supports a configurable clock by writing the SCK_POL/SCK_PHA bits, as well as both master and slave mode. The figures below show the timing requirements in different settings.

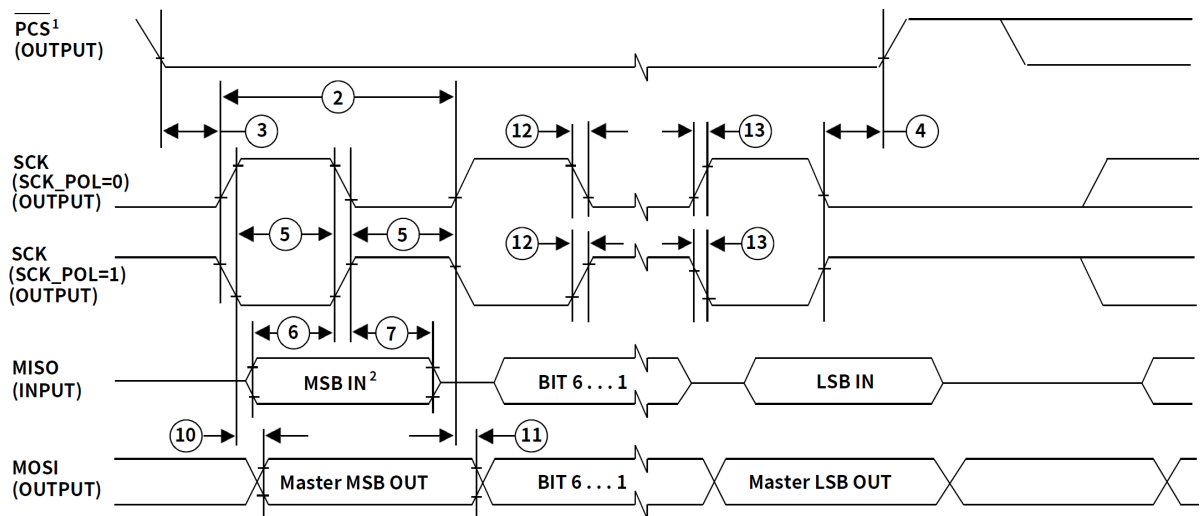
Figure 5. FCSPI master mode timing (SCK_PHA=0)



Note:

1. If configured as an output.

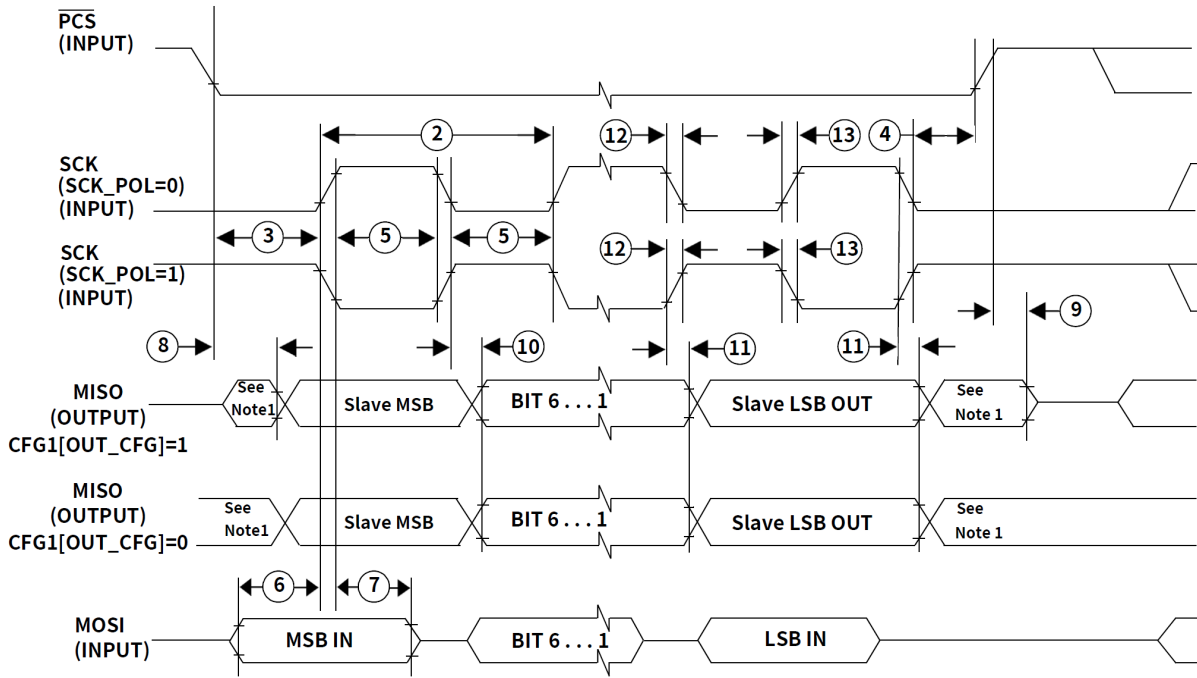
Figure 6. FCSPI master mode timing (SCK_PHA=1)



Note:

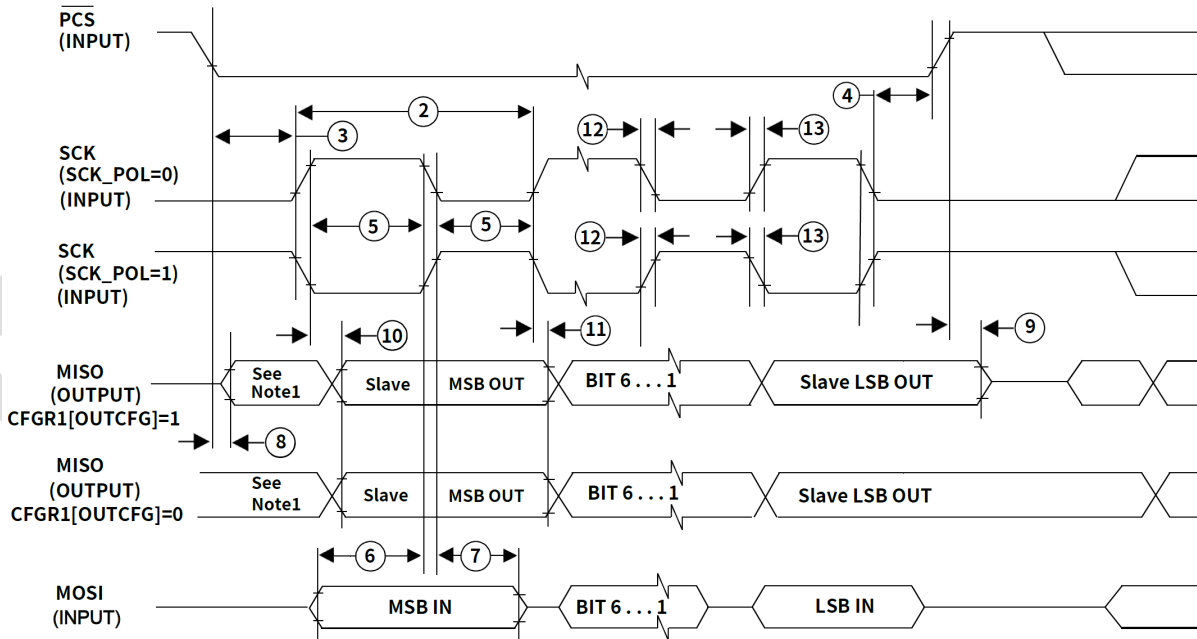
1. If configured as an output.
2. LSBF = 0. For LSBF = 1, bit order is LSB, bit 1, ..., bit 6, MSB.

Figure 7. FCSPi slave mode timing (SCK_PHA=0)



Note:
1. The bus is driven but may not be equal to the valid serial data being sent.

Figure 8. FCSPi slave mode timing (SCK_PHA=1)



Note:
1. The bus is driven but may not be equal to the valid serial data being sent.

The below is the FCSPI 3.0-3.6V electrical specification.

Table 27. FCSPI 3V specification

3.0 - 3.6 V							
Normal Pad (master)							
Number	Symbol	Description	Min.	Typ.	Max.	Unit	Notes
1	f _{op}	Frequency of operation (loopback)	-	-	15	MHz	
		Frequency of operation (internal clock)	-	-	12.5	MHz	
2	t _{sck}	SCK period (loopback)	66.7	-	-	ns	
		SCK period (internal clock)	80	-	-	ns	
3	t _{Lead}	Enable lead time	-	1/2	-	t _{sck}	
4	t _{Lag}	Enable Lag time	-	1/2	-	t _{sck}	
5	t _{wsck}	SCK high/low width	-	-	-	ns	
6	t _{su}	Data Setup time (loopback)	6	-	-	ns	
		Data Setup time (internal clock)	30	-	-	ns	
7	t _{HI}	Data Hold time (loopback)	5.5	-	-	ns	
		Data Hold time (internal clock)	0	-	-	ns	
10	t _v	Data Valid (after SCK edge)	-	-	5	ns	
11	t _{HO}	Data Hold time (outputs)	-10	-	-	ns	
12	t _{RFI}	Rise or Fall time (inputs)	0.5	-	3	ns	
13	t _{RFO}	Rise or Fall time (outputs)	2.8	-	7	ns	
Fast Pad (master)							
Number	Symbol	Description	Min.	Typ.	Max.	Unit	Notes
1	f _{op}	Frequency of operation (loopback)	-	-	20	MHz	
		Frequency of operation (internal clock)	-	-	18.75	MHz	
2	t _{sck}	SCK period (loopback)	50	-	-	ns	
		SCK period (internal clock)	53.28	-	-	ns	
3	t _{Lead}	Enable lead time	-	1/2	-	t _{sck}	
4	t _{Lag}	Enable Lag time	-	1/2	-	t _{sck}	
5	t _{wsck}	SCK high/low width	-	-	-	ns	
6	t _{su}	Data Setup time (loopback)	4	-	-	ns	
		Data Setup time (internal clock)	20	-	-	ns	
7	t _{HI}	Data Hold time (loopback)	5	-	-	ns	
		Data Hold time (internal clock)	0	-	-	ns	
10	t _v	Data Valid (after SCK edge)	-	-	5	ns	
11	t _{HO}	Data Hold time (outputs)	-10	-	-	ns	
12	t _{RFI}	Rise or Fall time (inputs)	0.5	-	3	ns	
13	t _{RFO}	Rise or Fall time (outputs)	1.8	-	8	ns	

Table 27. FCSPI 3V specification (continued)

Normal Pad (slave)							
Number	Symbol	Description	Min.	Typ.	Max.	Unit	Notes
1	f_{op}	Frequency of operation	-	-	12.5	MHz	
2	t_{sck}	SCK period	80	-	-	ns	
3	t_{Lead}	Enable lead time	-	1/2	-	t_{sck}	
4	t_{Lag}	Enable Lag time	-	1/2	-	t_{sck}	
5	t_{wsck}	SCK high/low width	-	-	-	ns	
6	t_{su}	Data Setup time	4	-	-	ns	
7	t_{HI}	Data Hold time	4	-	-	ns	
8	t_a	Slave access time	-	-	40	ns	
9	t_{dis}	Slave MISO disable time	-	-	40	ns	
10	t_v	Data Valid (after SCK edge)	-	-	30	ns	
11	t_{HO}	Data Hold time (outputs)	4	-	-	ns	
12	t_{RFI}	Rise or Fall time (inputs)	0.5	-	3	ns	
13	t_{RFo}	Rise or Fall time (outputs)	2.8	-	7	ns	
Fast Pad (slave)							
Number	Symbol	Description	Min.	Typ.	Max.	Unit	Notes
1	f_{op}	Frequency of operation	-	-	15	MHz	
2	t_{sck}	SCK period	66.7	-	-	ns	
3	t_{Lead}	Enable lead time	-	1/2	-	t_{sck}	
4	t_{Lag}	Enable Lag time	-	1/2	-	t_{sck}	
5	t_{wsck}	SCK high/low width	-	-	-	ns	
6	t_{su}	Data Setup time	4	-	-	ns	
7	t_{HI}	Data Hold time	4	-	-	ns	
8	t_a	Slave access time	-	-	33.3	ns	
9	t_{dis}	Slave MISO disable time	-	-	33.3	ns	
10	t_v	Data Valid (after SCK edge)	-	-	21	ns	
11	t_{HO}	Data Hold time (outputs)	4	-	-	ns	
12	t_{RFI}	Rise or Fall time (inputs)	0.5	-	3	ns	
13	t_{RFo}	Rise or Fall time (outputs)	1.8	-	8	ns	

The below is the FCSPI 4.5 to 5.5 V electrical specification.

Table 28. FCSPI 5V specification

4.5 - 5.5 V							
Normal Pad (master)							
Number	Symbol	Description	Min.	Typ.	Max.	Unit	Notes
1	f _{op}	Frequency of operation (loopback)	-	-	18.75	MHz	
		Frequency of operation (internal clock)	-	-	15	MHz	
2	t _{sck}	SCK period (loopback)	53.28	-	-	ns	
		SCK period (internal clock)	66.7	-	-	ns	
3	t _{Lead}	Enable lead time	-	1/2	-	t _{sck}	
4	t _{Lag}	Enable Lag time	-	1/2	-	t _{sck}	
5	t _{wsck}	SCK high/low width	-	-	-	ns	
6	t _{su}	Data Setup time (loopback)	5.5	-	-	ns	
		Data Setup time (internal clock)	24	-	-	ns	
7	t _{HI}	Data Hold time (loopback)	5	-	-	ns	
		Data Hold time (internal clock)	0	-	-	ns	
10	t _v	Data Valid (after SCK edge)	-	-	5	ns	
11	t _{HO}	Data Hold time (outputs)	-10	-	-	ns	
12	t _{rFi}	Rise or Fall time (inputs)	0.5	-	3	ns	
13	t _{rFo}	Rise or Fall time (outputs)	2.8	-	7	ns	
Fast Pad (master)							
Number	Symbol	Description	Min.	Typ.	Max.	Unit	Notes
1	f _{op}	Frequency of operation (loopback)	-	-	24	MHz	
		Frequency of operation (internal clock)	-	-	18.75	MHz	
2	t _{sck}	SCK period (loopback)	41.67	-	-	ns	
		SCK period (internal clock)	53.28	-	-	ns	
3	t _{Lead}	Enable lead time	-	1/2	-	t _{sck}	
4	t _{Lag}	Enable Lag time	-	1/2	-	t _{sck}	
5	t _{wsck}	SCK high/low width	-	-	-	ns	
6	t _{su}	Data Setup time (loopback)	4	-	-	ns	
		Data Setup time (internal clock)	17	-	-	ns	
7	t _{HI}	Data Hold time (loopback)	5	-	-	ns	
		Data Hold time (internal clock)	0	-	-	ns	
10	t _v	Data Valid (after SCK edge)	-	-	5	ns	
11	t _{HO}	Data Hold time (outputs)	-10	-	-	ns	
12	t _{rFi}	Rise or Fall time (inputs)	0.5	-	3	ns	
13	t _{rFo}	Rise or Fall time (outputs)	1.8	-	8	ns	

Table 28. FCSP1 5V specification (continued)

Normal Pad (slave)							
Number	Symbol	Description	Min.	Typ.	Max.	Unit	Notes
1	f_{op}	Frequency of operation	-	-	12.5	MHz	
2	t_{sck}	SCK period	80	-	-	ns	
3	t_{Lead}	Enable lead time	-	1/2	-	t_{sck}	
4	t_{Lag}	Enable Lag time	-	1/2	-	t_{sck}	
5	t_{wsck}	SCK high/low width	-	-	-	ns	
6	t_{su}	Data Setup time	4	-	-	ns	
7	t_{HI}	Data Hold time	4	-	-	ns	
8	t_a	Slave access time	-	-	40	ns	
9	t_{dis}	Slave MISO disable time	-	-	40	ns	
10	t_v	Data Valid (after SCK edge)	-	-	25	ns	
11	t_{HO}	Data Hold time (outputs)	4	-	-	ns	
12	t_{RFi}	Rise or Fall time (inputs)	0.5	-	3	ns	
13	t_{RFo}	Rise or Fall time (outputs)	2.8	-	7	ns	
Fast Pad (slave)							
Number	Symbol	Description	Min.	Typ.	Max.	Unit	Notes
1	f_{op}	Frequency of operation	-	-	20	MHz	
2	t_{sck}	SCK period	50	-	-	ns	
3	t_{Lead}	Enable lead time	-	1/2	-	t_{sck}	
4	t_{Lag}	Enable Lag time	-	1/2	-	t_{sck}	
5	t_{wsck}	SCK high/low width	-	-	-	ns	
6	t_{su}	Data Setup time	4	-	-	ns	
7	t_{HI}	Data Hold time	4	-	-	ns	
8	t_a	Slave access time	-	-	25	ns	
9	t_{dis}	Slave MISO disable time	-	-	25	ns	
10	t_v	Data Valid (after SCK edge)	-	-	18	ns	
11	t_{HO}	Data Hold time (outputs)	4	-	-	ns	
12	t_{RFi}	Rise or Fall time (inputs)	0.5	-	3	ns	
13	t_{RFo}	Rise or Fall time (outputs)	1.8	-	8	ns	

8.2 I2S Specification

The figures below show the I2S0/1 timing diagram/requirement.

Figure 9. I2S master mode timing diagram

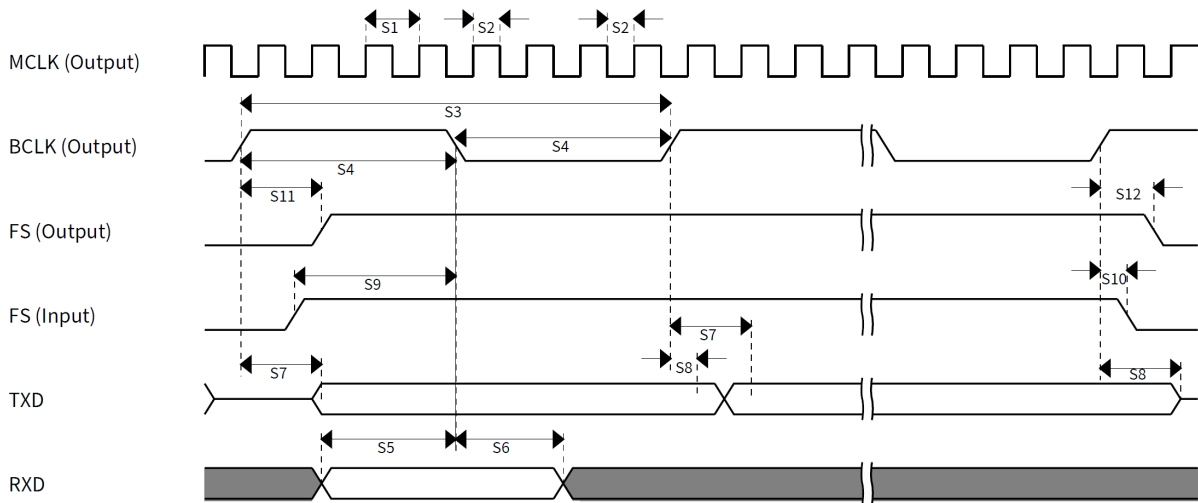


Figure 10. I2S slave timing diagram

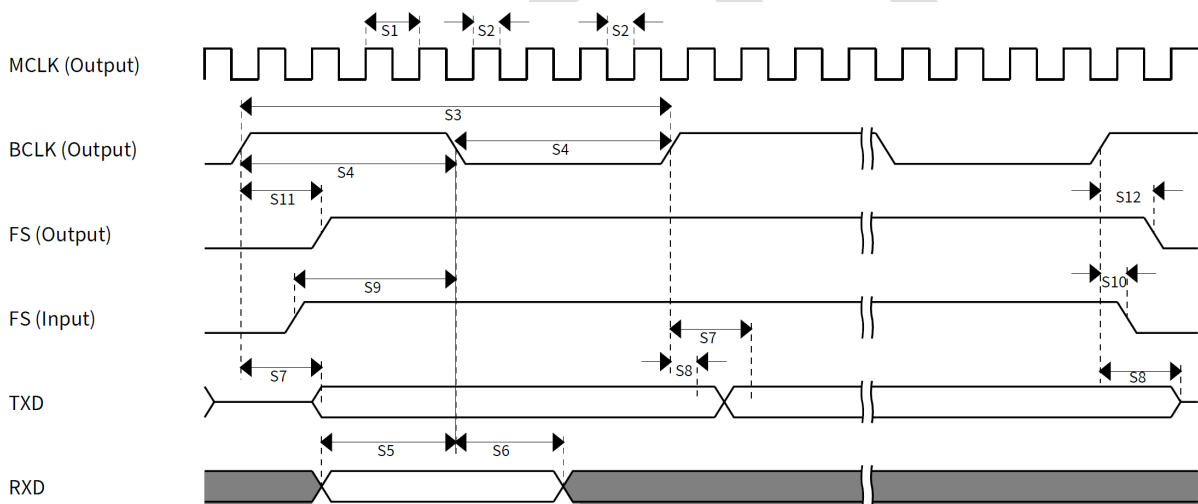


Table 29. I2S electrical specification

I2S Master							
Number	Symbol	Description	Min.	Typ.	Max.	Unit	Notes
1	S ₁	I2S_MCLK cycle time	-	-	40	ns	-
2	S ₂	I2S_MCLK duty	45%	-	55%	-	-
3	S ₃	I2S_BCLK cycle time	80	-	-	ns	-
4	S ₄	I2S_BCLK duty	45%	-	55%	-	-
5	S ₅	I2S_RXD input setup (I2S_BCLK)	28	-	-	ns	-
6	S ₆	I2S_RXD input hold (I2S_BCLK)	0	-	-	ns	-
7	S ₇	I2S_BCLK to I2S_TXD output valid	-	-	8	ns	-
8	S ₈	I2S_BCLK to I2S_TXD output invalid	-2	-	-	ns	-

Table 29. I2S electrical specification (continued)

9	S ₉	I2S_FS input setup (I2S_BCLK)	28	-	-	ns	-
10	S ₁₀	I2S_FS input hold (I2S_BCLK)	0	-	-	ns	
11	S ₁₁	I2S_BCLK to I2S_FS output valid	-	-	8	ns	
12	S ₁₂	I2S_BCLK to I2S_FS output invalid	-2	-	-	ns	
I2S Slave							
Number	Symbol	Description	Min.	Typ.	Max.	Unit	Notes
1	S ₁₃	I2S_BCLK cycle time	80	-	-	ns	
2	S ₁₄	I2S_BCLK duty	45%	-	55%	-	
3	S ₁₅	I2S_RXD input setup (I2S_BCLK)	3	-	-	ns	
4	S ₁₆	I2S_RXD input hold (I2S_BCLK)	3	-	-	ns	
5	S ₁₇	I2S_BCLK to I2S_TXD output valid	-	-	30	ns	
6	S ₁₈	I2S_BCLK to I2S_TXD output invalid	0	-	-	ns	
7	S ₁₉	I2S_FS input setup (I2S_BCLK)	3	-	-	ns	
8	S ₂₀	I2S_FS input hold (I2S_BCLK)	3	-	-	ns	
9	S ₂₁	I2S_BCLK to I2S_FS output valid	-	-	30	ns	
10	S ₂₂	I2S_BCLK to I2S_FS output invalid	0	-	-	ns	

8.3 ENET Specification

The Ethernet (ENET) supports MII/RMII 10M/100M specification. For RMII, it supports both 50 MHz and 5MHz RMII clocks.

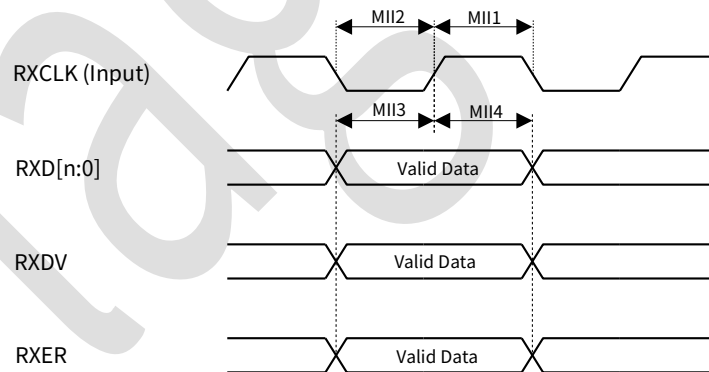
Figure 11. MII receive timing diagram

Figure 12. MII transmit timing diagram

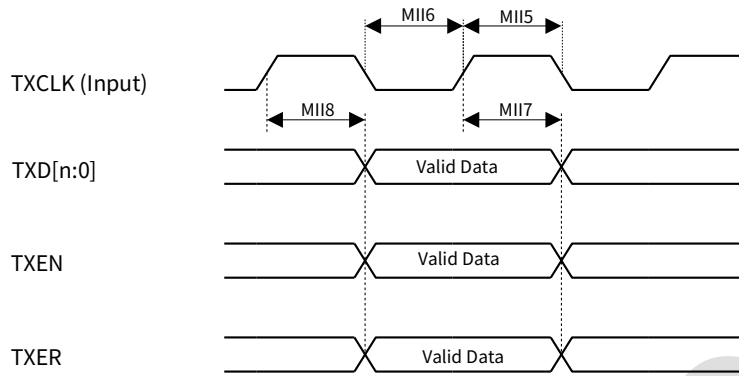


Figure 13. RMI receive timing diagram

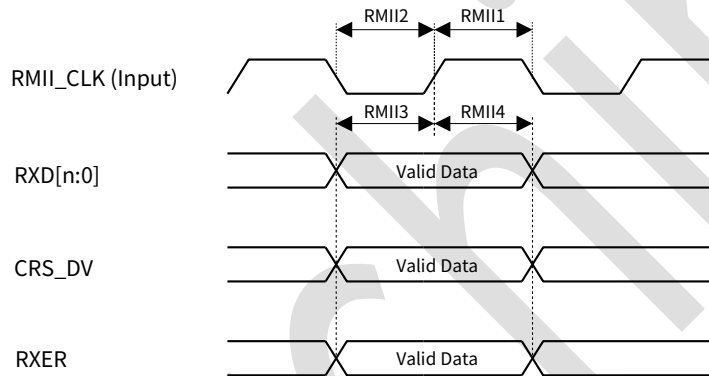


Figure 14. RMI transmit timing diagram

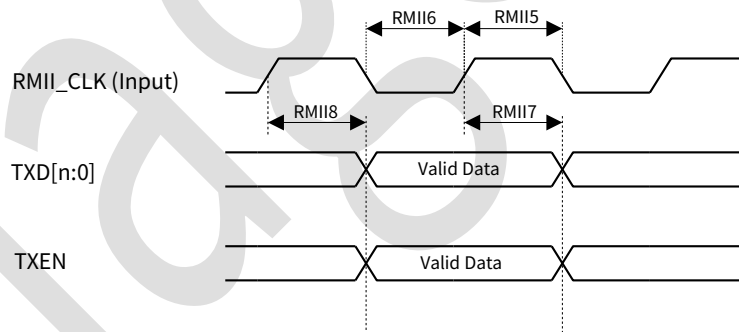


Table 30. MII/RMI electrical specification

MII							
Number	Symbol	Description	Min.	Typ.	Max.	Unit	Notes
1	MII ₁	RXCLK frequency	-	-	25	MHz	
2	MII ₂	RXCLK duty	35%	-	65%	-	
3	MII ₃	RXD[3:0], RXDV, RXER to RXCLK setup	5	-	-	ns	
4	MII ₄	RXD[3:0], RXDV, RXER to RXCLK hold	5	-	-	ns	
5	MII ₅	TXCLK frequency	-	-	25	MHz	
6	MII ₆	TXCLK duty	35%	-	65%	-	
7	MII ₇	TXCLK to TXD[3:0], TXEN, TXER invalid	2	-	-	ns	
8	MII ₈	TXCLK to TXD[3:0], TXEN, TXER valid	-	-	25	ns	

Table 30. MII/RMII electrical specification (continued)

RMII							
Number	Symbol	Description	Min.	Typ.	Max.	Unit	Notes
1	RMII ₁ /RMII ₅	RMII_CLK frequency	-	-	50	MHz	
2	RMII ₂ /RMII ₆	RMII_CLK duty	45%	-	55%	-	
3	RMII ₃	RXD[1:0], CRS_DV, RXER to RMII_CLK setup	4	-	-	ns	
4	RMII ₄	RXD[1:0], CRS_DV, RXER to RMII_CLK hold	2	-	-	ns	
5	RMII ₇	RMII_CLK to TXD[1:0], TXEN invalid	2	-	-	ns	
6	RMII ₈	RMII_CLK to TXD[1:0], TXEN valid	-	-	15	ns	

The chip also supports the MDC interface for external PHY configuration.

Figure 15. MDIO timing diagram

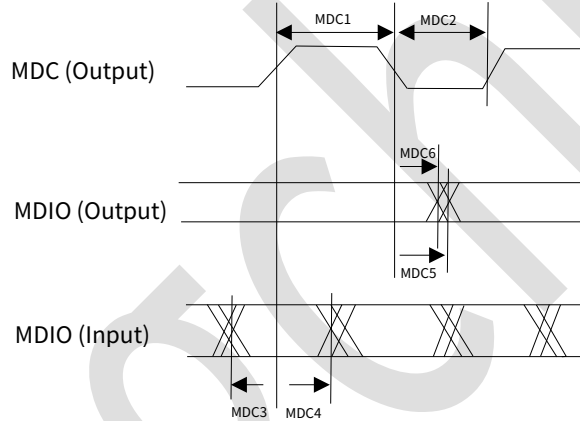


Table 31. MDIO electrical specification

MDIO							
Number	Symbol	Description	Min.	Typ.	Max.	Unit	Notes
1	MDC ₁	MDC clock frequency	-	-	2.5	MHz	
2	MDC ₂	MDC duty	40%	-	60%	-	
3	MDC ₃	MDIO to MDC rising edge setup	25	-	-	ns	
4	MDC ₄	MDIO to MDC rising edge hold	0	-	-	ns	
5	MDC ₅	MDC falling edge to MDIO output valid	-	-	25	ns	
6	MDC ₆	MDC falling edge to MDIO output invalid	-10	-	-	ns	

8.4 OSPI Specification

Table 32. OSPI timing

3.0 - 3.6 V								
Description	Symbol	Unit	SDR		DDR			
			PAD Loopback		PAD Loopback		External RWDS	
			Min.	Max.	Min.	Max.	Min.	Max.
SCK Clock Frequency	F_SCK	MHz	-	50	-	33	-	50
SCK Clock Period	t_SCK	ns	20	-	33	-	20	-
SCK Duty Cycle	Tch, Tcl	%	45	55	45	55	45	55
Data Input Setup Time	Tis	ns	3	-	3	-	-0.5	0.5
Data Input Hold Time	Tih	ns	1	-	1	-	-0.5	0.5
Data Output Valid Time	Tov	ns	-	6	-	6	-	6
Data Output In-Valid Time	Tiv	ns	-	3	-	3	-	3
CS to SCK	Tcs	ns	20	-	20	-	20	-
SCK to CS	Tsc	ns	10	-	10	-	10	-
Input Transition	Titr	ns	2.5					
Output Load	Cload	pf	15					

Figure 16. OSPI SDR/DDR in mode

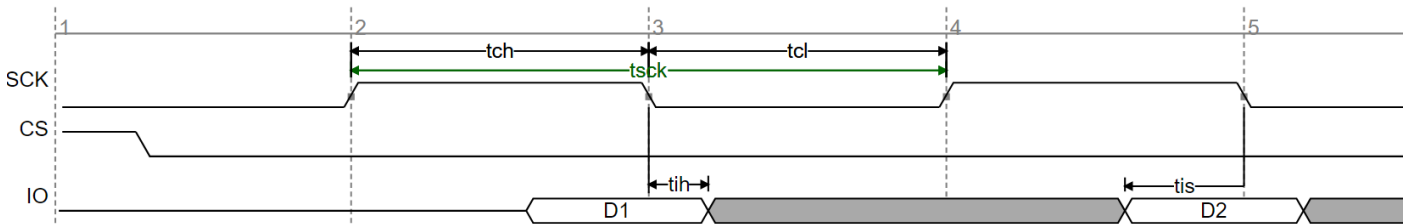


Figure 17. OSPI SDR/DDR out mode

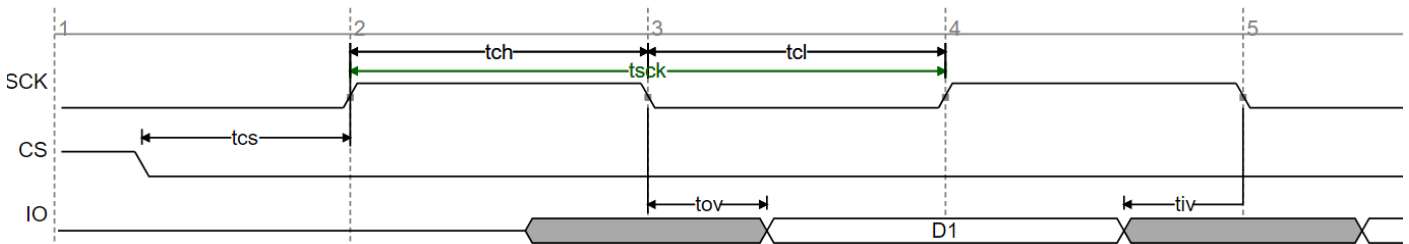
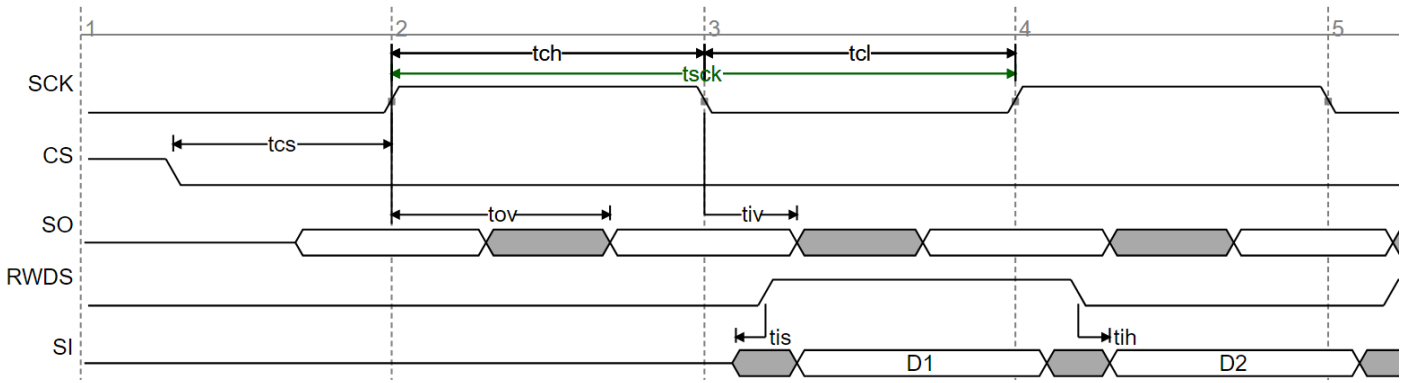


Figure 18. HyperRAM mode



Flagchip

Chapter 9 Debug Modules

The chip supports both JTAG and Serial Wire Debug (SWD) interface, and it also has the TPIU interface.

9.1 SWD Specification

Figure 19. SWD clock timing diagram

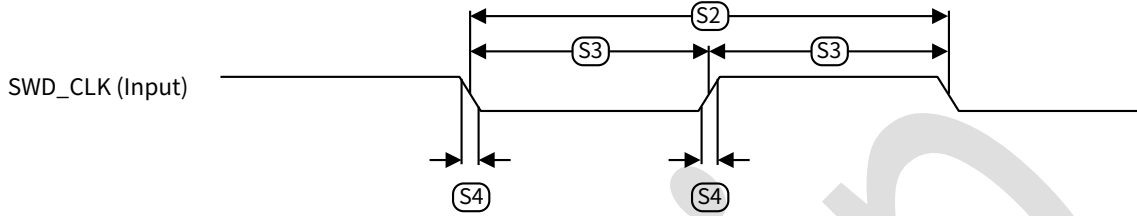


Figure 20. SWD data timing diagram

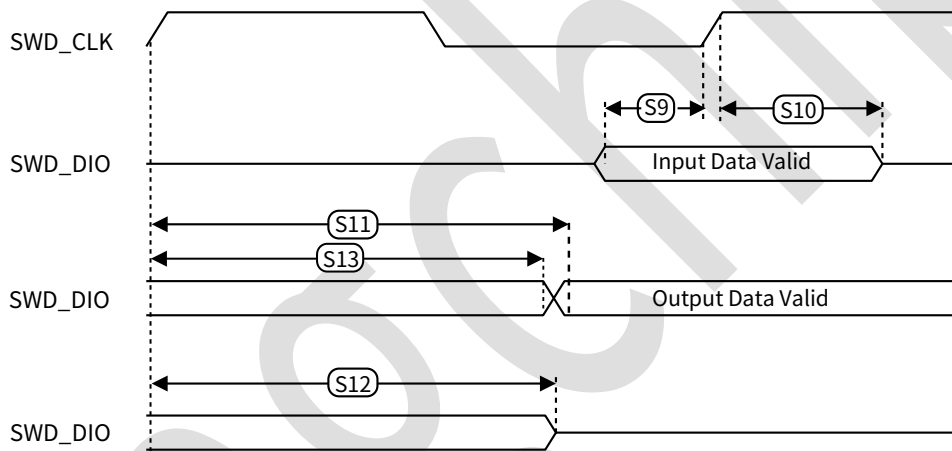


Table 33. SWD electrical specification

SWD							
Number	Symbol	Description	Min.	Typ.	Max.	Unit	Notes
1	S ₁	SWD_CLK frequency	-	-	25	MHz	
2	S ₂	SWD_CLK period	1/S ₁	-	-	ns	
3	S ₃	SWD_CLK clock pulse width	S ₂ /2 - 5	-	S ₂ /2 + 5	ns	
4	S ₄	SWD_CLK rise or fall time	1	-	3	ns	
5	S ₅	SCK high/low width	-	-	-	ns	
6	S ₆	SWD_DIO data setup time	6	-	-	ns	
7	S ₇	SWD_DIO data hold time	3	-	-	ns	
8	S ₈	SWD_CLK to SWD_DIO data valid	-	-	-	ns	
9	S ₉	SWD_CLK to SWD_DIO data high-z	0	-	-	ns	
10	S ₁₀	SWD_CLK to SWD_DIO data invalid	0	-	-	ns	

9.2 Trace Block

Figure 21. Trace block timing diagram

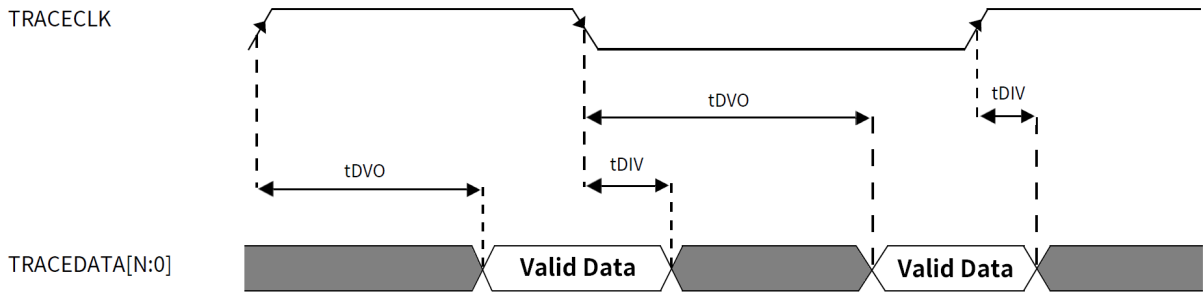


Table 34. Trace block electrical specification

Trace Interface on normal pad							
Number	Symbol	Description	Min.	Typ.	Max.	Unit	Notes
1	f_{trace}	Frequency of operation	-	-	25	MHz	
2	t_{dvo}	Data output valid	-	-	7.5	ns	
3	t_{dvi}	Data output invalid	-4	-	-	ns	
Trace Interface on HS pad							
Number	Symbol	Description	Min.	Typ.	Max.	Unit	Notes
1	f_{trace}	Frequency of operation	-	-	50	MHz	
2	t_{dvo}	Data output valid	-	-	7	ns	
3	t_{dvi}	Data output invalid	0	-	-	ns	

9.3 JTAG Interface

Figure 22. JTAG clock timing diagram

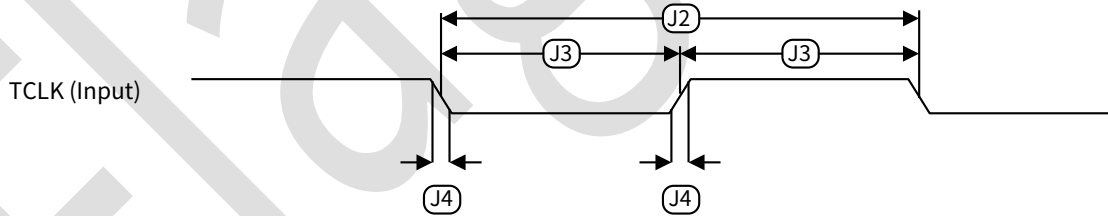


Figure 23. Boundary timing diagram

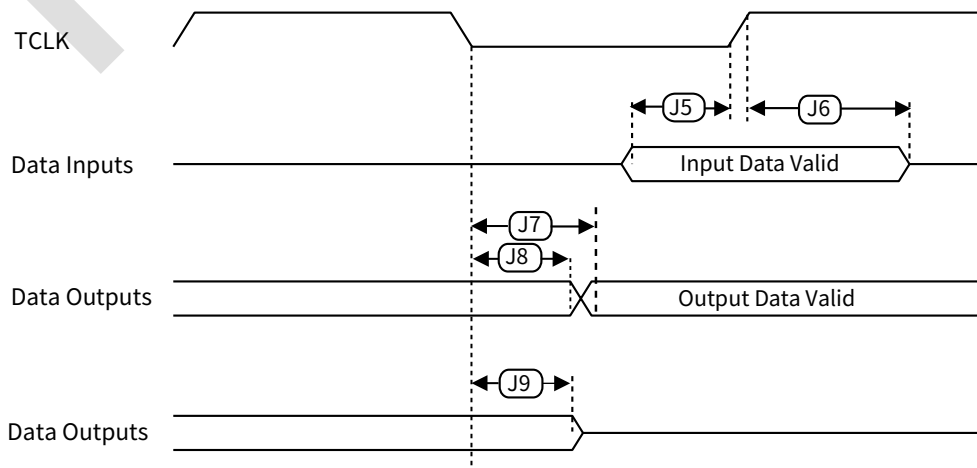


Figure 24. JTAG TAP timing diagram

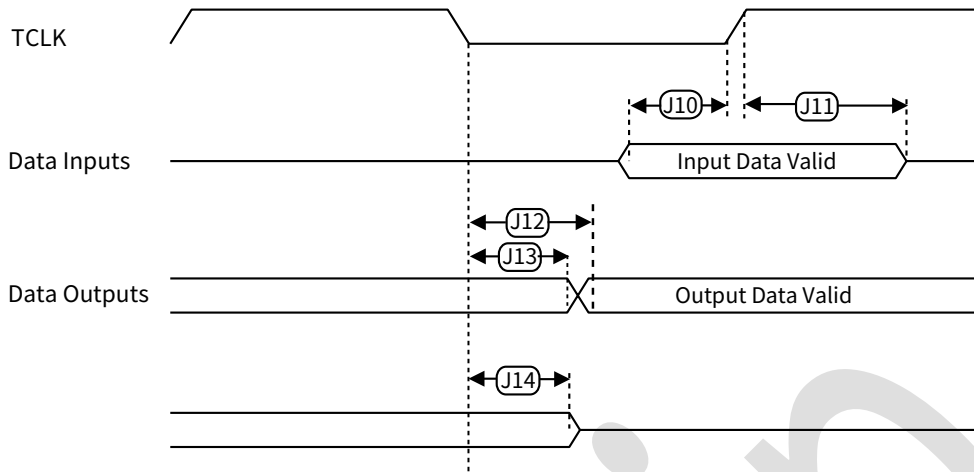


Table 35. JTAG electrical specification

JTAG							
Number	Symbol	Description	Min.	Typ.	Max.	Unit	Notes
1	J ₁	TCLK frequency	-	-	15	MHz	
2	J ₂	TCLK period	64	-	-	ns	
3	J ₃	TCLK duty	45%	-	55%	-	
4	J ₄	TCLK rise and fall times	1	-	3	ns	
5	J ₅	Boundary input setup (TCLK)	6	-	-	ns	
6	J ₆	Boundary input hold (TCLK)	2	-	-	ns	
7	J ₇	TCLK low to Boundary output valid	-	-	32	ns	
8	J ₈	TCLK low to Boundary output invalid	0	-	-	ns	
9	J ₉	TCLK low to Boundary output high-Z	-	-	32	ns	
10	J ₁₀	TMS/TDI setup (TCLK)	6	-	-	ns	
11	J ₁₁	TMS/TDI hold (TCLK)	2	-	-	ns	
12	J ₁₂	TCLK low to TDO output valid	-	-	32	ns	
13	J ₁₃	TCLK low to TDO output invalid	0	-	-	ns	
14	J ₁₄	TCLK low to TDO output high-Z	-	-	32	ns	

Chapter 10 Package

10.1 Thermal Data

The following table shows the FC4150F2M and FC4150F1M_A package thermal data. The user can calculate the maximum junction based on the package type, environment and PCB etc.

Table 36. Thermal package simulation data

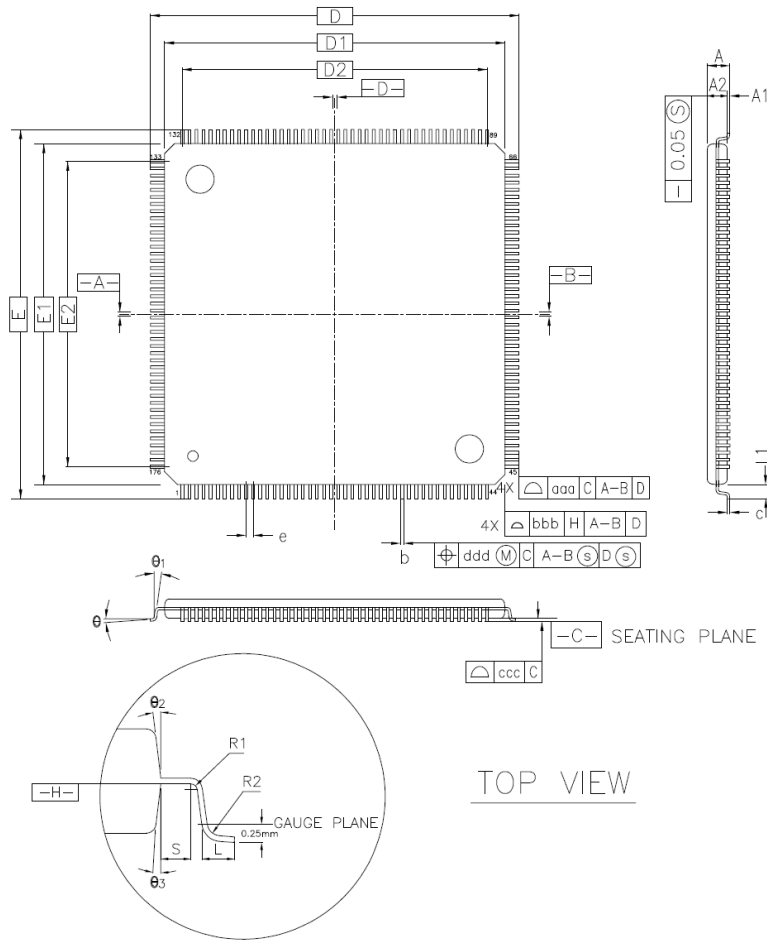
R θ JA	Description	Package	FC4150F2M	FC4150F1M_A	Unit
Thermal resistance, Junction to Ambient (Natural Convection)	Single-layer board (1s)	176LQFP-EP	27	-	°C/W
	Four-layer board (2s2p)		22	-	
	Single-layer board (1s)	144LQFP	45	45	
	Four-layer board (2s2p)		41	41	
	Single-layer board (1s)	100LQFP	47	47	
	Four-layer board (2s2p)		43	43	
Thermal resistance, Junction to Ambient (@1m/s)	Single-layer board (1s)	176LQFP-EP	21	-	
	Four-layer board (2s2p)		18	-	
	Single-layer board (1s)	144LQFP	36	36	
	Four-layer board (2s2p)		32	32	
	Single layer board (1s)	100LQFP	37	37	
	Four-layer board (2s2p)		32	32	

10.2 Package Dimension

For FC4150F2M, there are 100LQFP, 144LQFP and 176LQFP-EP package options. For FC4150F1M_A, there are 100LQFP and 144LQFP package options.

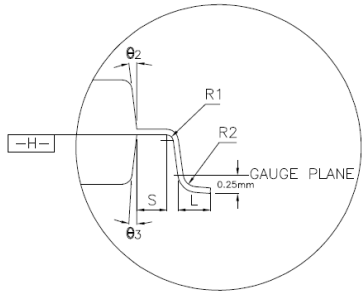
The following figures show the package dimensions.

Figure 25. 176LQFP-EP package

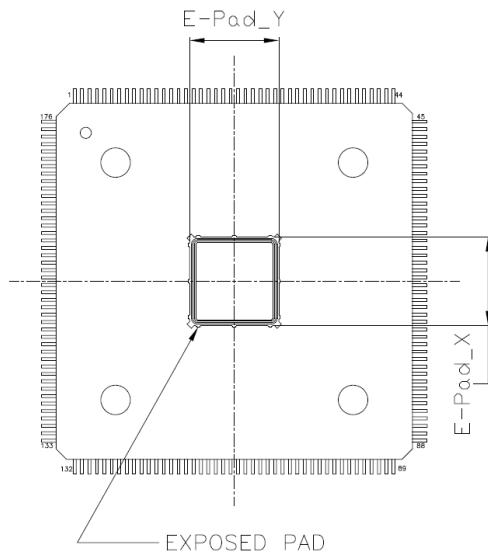


CONTROL DIMENSIONS ARE IN MILLIMETERS.

SYMBOL	MILLIMETER			INCH		
	MIN.	NOM.	MAX.	MIN.	NOM.	MAX.
A	—	—	1.60	—	—	0.063
A1	0.05	—	0.15	0.002	—	0.006
A2	1.35	1.40	1.45	0.053	0.055	0.057
D	26 BSC.		—	1.024 BSC.		—
D1	24 BSC.		—	0.945 BSC.		—
E	26 BSC.		—	1.024 BSC.		—
E1	24 BSC.		—	0.945 BSC.		—
R2	0.08	—	0.20	0.003	—	0.008
R1	0.08	—	—	0.003	—	—
θ	0	3.5	7	0	3.5	7
θ_1	0	—	—	0	—	—
θ_2	11	12	13	11	12	13
θ_3	11	12	13	11	12	13
c	0.09	0.127	0.20	0.004	0.005	0.008
L	0.45	0.60	0.75	0.018	0.024	0.030
L1	1.00 REF.		—	0.039 REF.		—
S	0.20	—	—	0.008	—	—



TOP VIEW



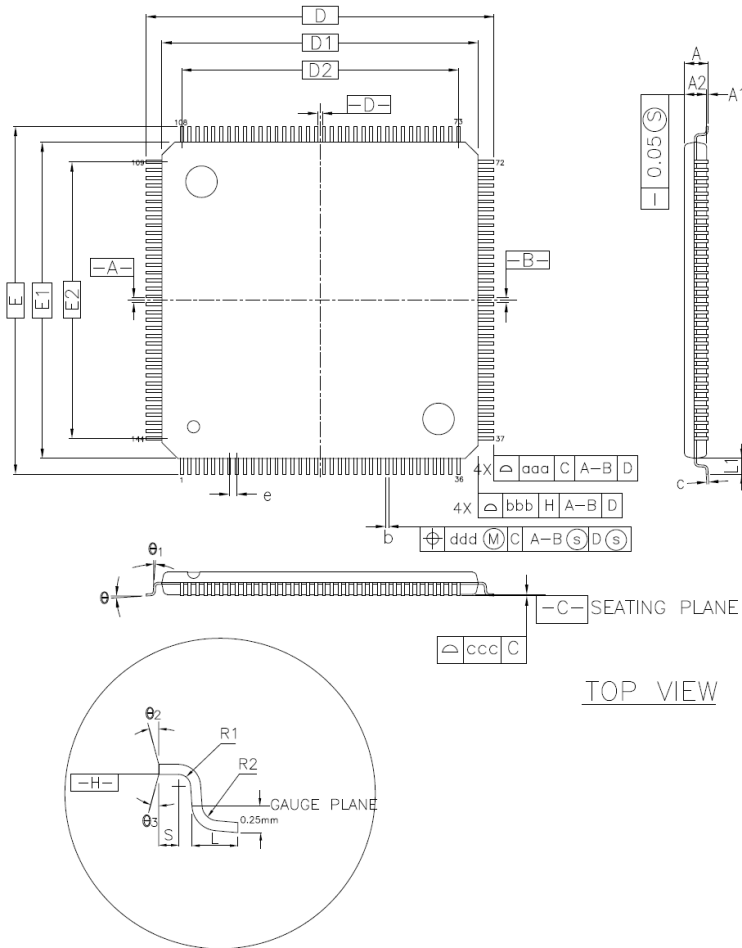
BOTTOM VIEW

SYMBOL	176L					
	MILLIMETER			INCH		
	MIN.	NOM.	MAX.	MIN.	NOM.	MAX.
b	0.17	0.20	0.27	0.007	0.008	0.011
e	0.50 BSC.		—	0.020 BSC.		—
D2	21.50		—	0.846		—
E2	21.50		—	0.846		—
E-Pad_X	6.00		—	0.236		—
E-Pad_Y	6.00		—	0.236		—
TOLERANCES OF FORM AND POSITION						
aaa	0.20		—	0.008		—
bbb	0.20		—	0.008		—
ccc	0.08		—	0.003		—
ddd	0.08		—	0.003		—

NOTES :

- DIMENSIONS D1 AND E1 DO NOT INCLUDE MOLD PROTRUSION.
- DIMENSION b DOES NOT INCLUDE DAMBAR PROTRUSION. ALLOWABLE DAMBAR PROTRUSION SHALL NOT CAUSE THE LEAD WIDTH TO EXCEED THE MAXIMUM b DIMENSION BY MORE THAN 0.08mm.
DAMBAR CAN NOT BE LOCATED ON THE LOWER RADIUS OR THE FOOT. THE MINIMUM SPACE BETWEEN PROTRUSION AND AN ADJACENT LEAD SHALL NOT BE LESS THAN 0.07mm.
- THE TOP PACKAGE BODY SIZE MAY BE SMALLER THAN THE BOTTOM PACKAGE BODY SIZE.

Figure 26. 144LQFP package



CONTROL DIMENSIONS ARE IN MILLIMETERS.

SYMBOL	MILLIMETER			INCH		
	MIN.	NOM.	MAX.	MIN.	NOM.	MAX.
A	—	—	1.60	—	—	0.063
A1	0.05	—	0.15	0.002	—	0.006
A2	1.35	1.40	1.45	0.053	0.055	0.057
D	22	BSC.	—	0.866	BSC.	—
D1	20	BSC.	—	0.787	BSC.	—
E	22	BSC.	—	0.866	BSC.	—
E1	20	BSC.	—	0.787	BSC.	—
R2	0.08	—	0.20	0.003	—	0.008
R1	0.08	—	—	0.003	—	—
θ	0	3.5	7	0	3.5	7
θ_1	0	—	—	0	—	—
θ_2	11	12	13	11	12	13
θ_3	11	12	13	11	12	13
c	0.09	0.127	0.20	0.004	0.005	0.008
L	0.45	0.60	0.75	0.018	0.024	0.030
L1	—	1.00	REF.	—	0.039	REF.
S	0.20	—	—	0.008	—	—

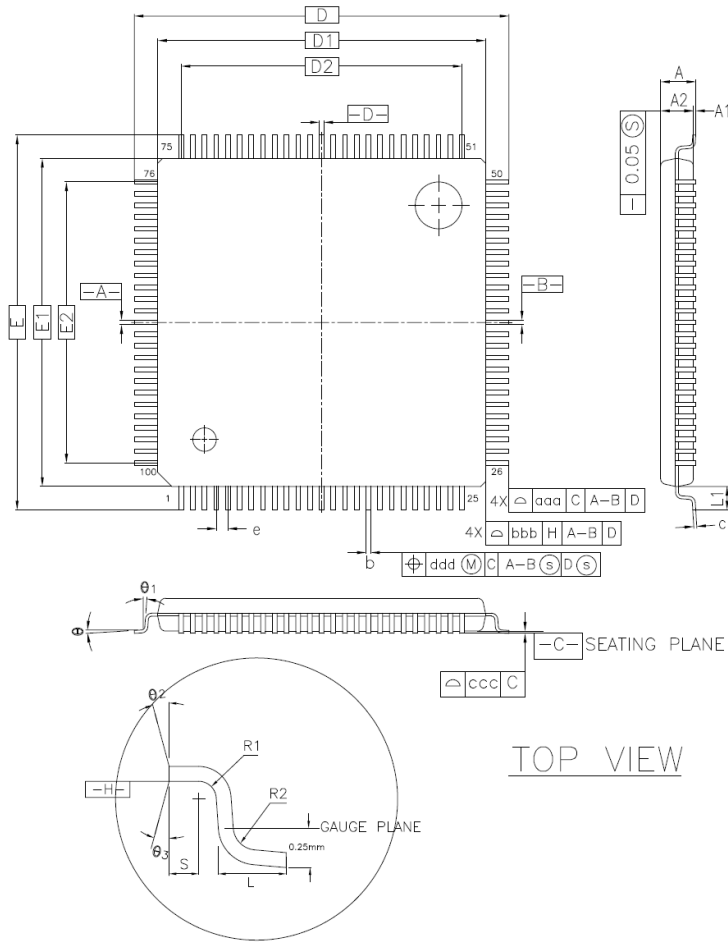
TOP VIEW

SYMBOL	144L					
	MILLIMETER			INCH		
	MIN.	NOM.	MAX.	MIN.	NOM.	MAX.
b	0.17	0.20	0.27	0.007	0.008	0.011
e	0.50	BSC.	—	0.020	BSC.	—
D2	17.50	—	—	0.689	—	—
E2	17.50	—	—	0.689	—	—
TOLERANCES OF FORM AND POSITION						
aaa	0.20	—	—	0.008	—	—
bbb	0.20	—	—	0.008	—	—
ccc	0.08	—	—	0.003	—	—
ddd	0.08	—	—	0.003	—	—

NOTES :

- DIMENSIONS D1 AND E1 DO NOT INCLUDE MOLD PROTRUSION.
- DIMENSION b DOES NOT INCLUDE DAMBAR PROTRUSION. ALLOWABLE DAMBAR PROTRUSION SHALL NOT CAUSE THE LEAD WIDTH TO EXCEED THE MAXIMUM b DIMENSION BY MORE THAN 0.08mm. DAMBAR CAN NOT BE LOCATED ON THE LOWER RADIUS OR THE FOOT. THE MINIMUM SPACE BETWEEN PROTRUSION AND AN ADJACENT LEAD SHALL NOT BE LESS THAN 0.07mm.
- THE TOP PACKAGE BODY SIZE MAY BE SMALLER THAN THE BOTTOM PACKAGE BODY SIZE.

Figure 27. 100LQFP package



CONTROL DIMENSIONS ARE IN MILLIMETERS.

SYMBOL	MILLIMETER			INCH		
	MIN.	NOM.	MAX.	MIN.	NOM.	MAX.
A	—	—	1.60	—	—	0.063
A1	0.05	—	0.15	0.002	—	0.006
A2	1.35	1.40	1.45	0.053	0.055	0.057
D	16 BSC.			0.630 BSC.		
D1	14 BSC.			0.551 BSC.		
E	16 BSC.			0.630 BSC.		
E1	14 BSC.			0.551 BSC.		
R2	0.08	—	0.20	0.003	—	0.008
R1	0.08	—	—	0.003	—	—
θ	0	3.5	7	0	3.5	7
θ_1	0	—	—	0	—	—
θ_2	11	12	13	11	12	13
θ_3	11	12	13	11	12	13
c	0.09	0.127	0.20	0.004	0.005	0.008
L	0.45	0.60	0.75	0.018	0.024	0.030
L ₁	1.00 REF.			0.039 REF.		
S	0.20	—	—	0.008	—	—

TOP VIEW

SYMBOL	100L					
	MILLIMETER			INCH		
	MIN.	NOM.	MAX.	MIN.	NOM.	MAX.
b	0.17	0.20	0.27	0.007	0.008	0.011
e	0.50 BSC.			0.020 BSC.		
D2	12.00			0.472		
E2	12.00			0.472		
TOLERANCES OF FORM AND POSITION						
aaa	0.20			0.008		
bbb	0.20			0.008		
ccc	0.08			0.003		
ddd	0.08			0.003		

NOTES :

- DIMENSIONS D1 AND E1 DO NOT INCLUDE MOLD PROTRUSION.
- DIMENSION b DOES NOT INCLUDE DAMBAR PROTRUSION. ALLOWABLE DAMBAR PROTRUSION SHALL NOT CAUSE THE LEAD WIDTH TO EXCEED THE MAXIMUM b DIMENSION BY MORE THAN 0.08mm.
DAMBAR CAN NOT BE LOCATED ON THE LOWER RADIUS OR THE FOOT. THE MINIMUM SPACE BETWEEN PROTRUSION AND AN ADJACENT LEAD SHALL NOT BE LESS THAN 0.07mm.
- THE TOP PACKAGE BODY SIZE MAY BE SMALLER THAN THE BOTTOM PACKAGE BODY SIZE.

Chapter 11 Pinout

The figures below demonstrate the pinouts for packages of the FC4150F2M and FC4150F1M_A.

Figure 28. 176LQFP-EP pinout

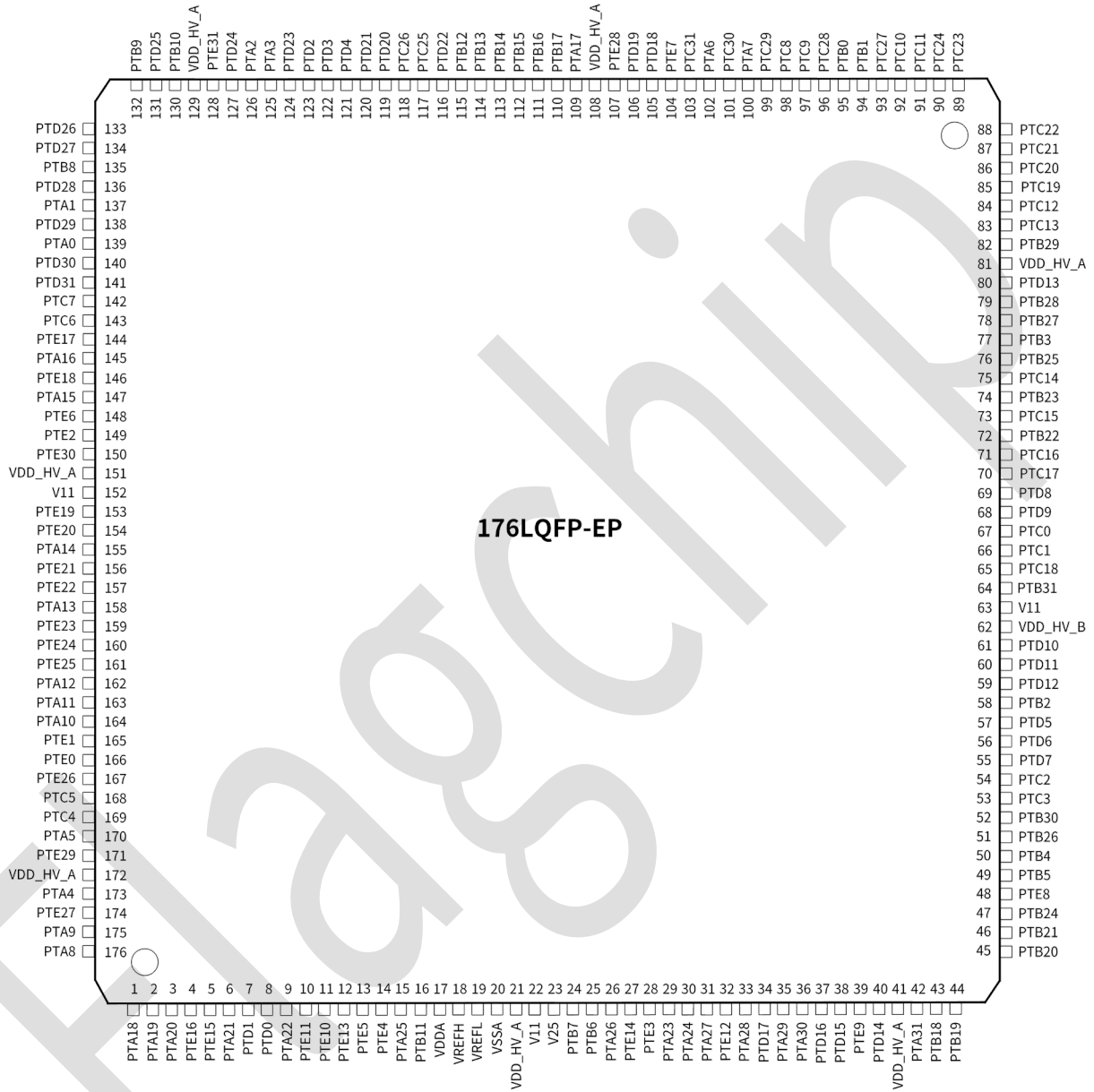


Figure 29. 144LQFP pinout

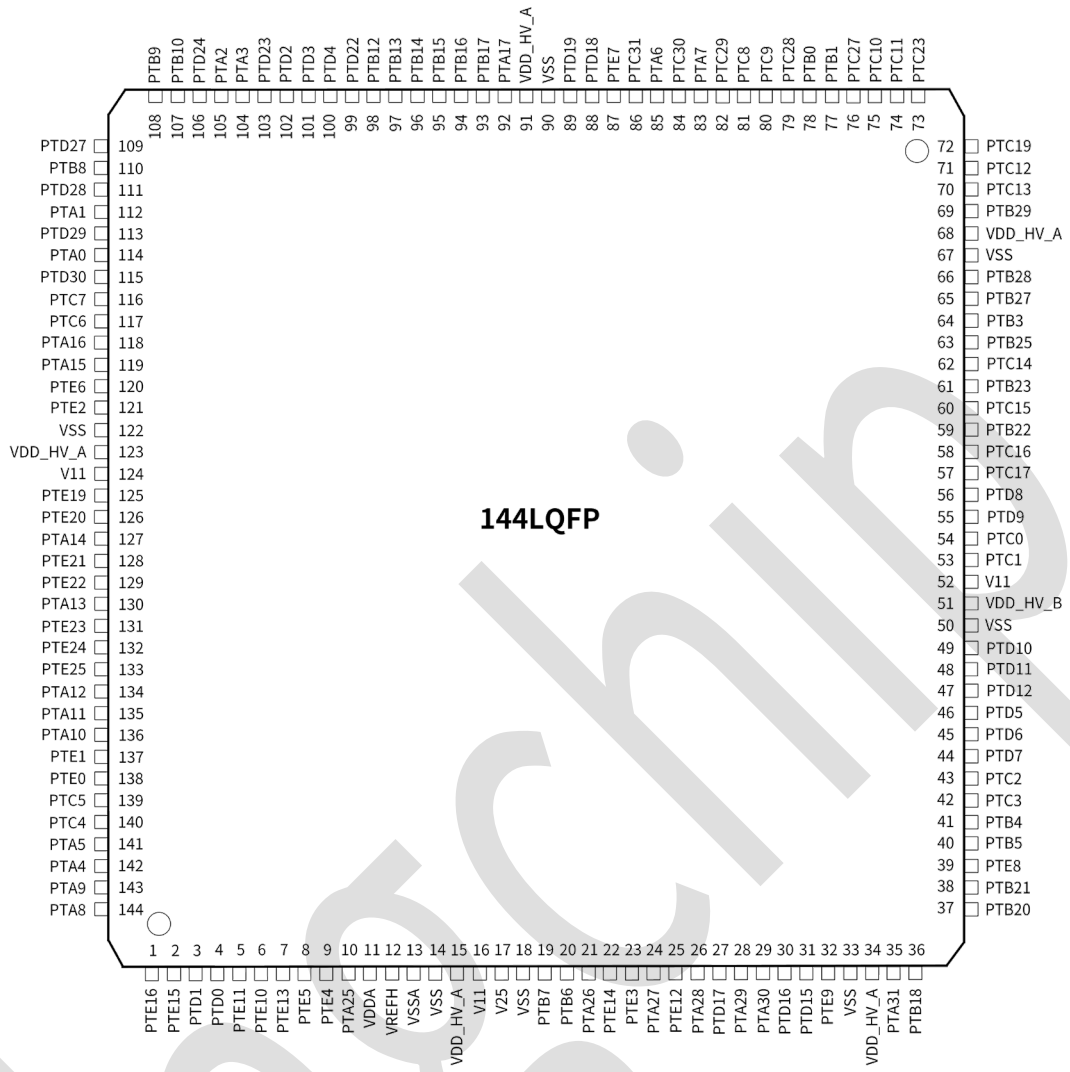
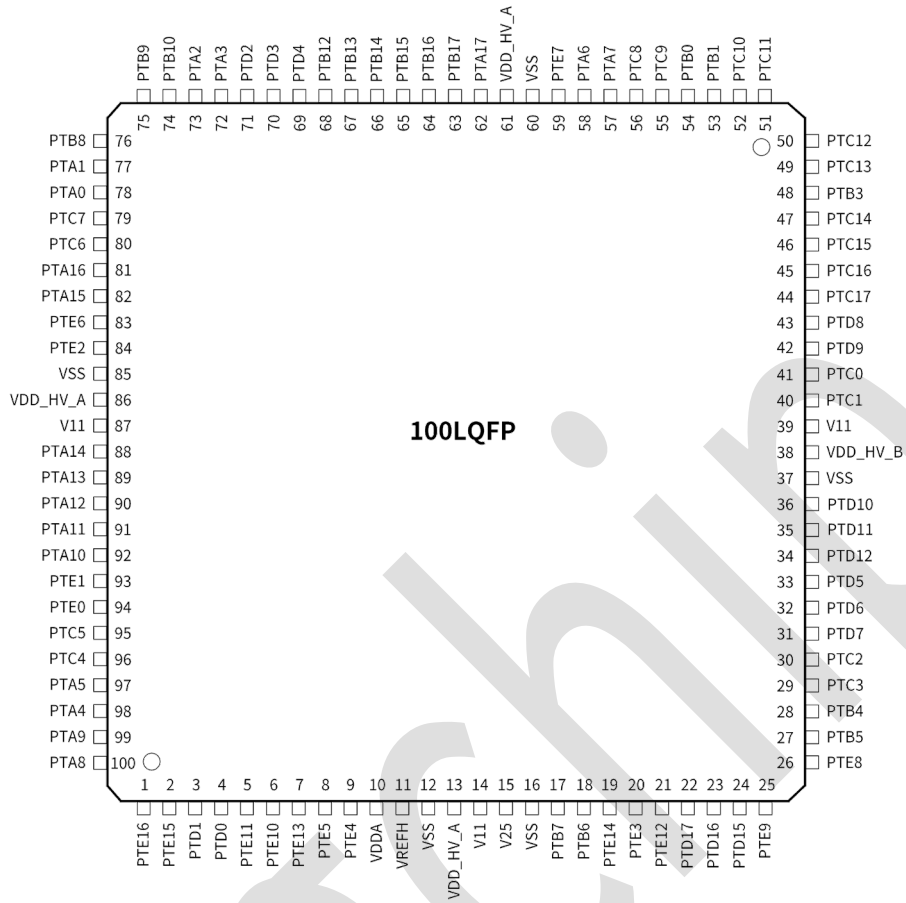


Figure 30. 100LQFP pinout



The table below lists the different peripheral functions mapped to different pins.

For detailed function pinout mapping, refer to the FC4150 Pinout.xlsx attached in FC4150 Reference Manual.

Table 37. FC4150F2M and FC4150F1M_A pin functions

100LQFP	144LQFP	176LQFP-EP	Pin Name	Functions																	
				ADC	AONTIMER	CMP	ENET/MII	TRACE	EXTAL/XTAL	FCIIC	FCSPI	FCUART	FLEX CAN	FTU	FWM	I2S	JTAG/SWD/TRACE	OSC 32K	OSPI	TRGSEL	RTC
-	-	1	PTA18	-	-	-	-	-	-	-	-	FCUART1_TX	-	FTU4_CH0	-	-	-	-	-	-	-
-	-	2	PTA19	-	-	-	-	-	-	-	-	FCUART1_RX	-	FTU4_CH1	-	-	-	-	-	-	-
-	-	3	PTA20	-	-	-	-	-	-	-	-	FCUART3_RTS	-	FTU4_CH2	-	-	-	-	-	-	-
1	1	4	PTE16	ADC1_SE6	-	-	-	-	-	-	FCSPI2_SIN	FCUART1_RTS	-	FTU2_CH7	-	-	-	-	-	TRGSEL_OUT7	-
2	2	5	PTE15	ADC1_SE2	-	-	-	-	-	-	FCSPI2_SCK	FCUART1_CTS	-	FTU2_CH6	-	-	-	-	-	TRGSEL_OUT6	-
-	-	6	PTA21	-	-	-	-	-	-	-	-	FCUART3_CTS	-	FTU4_CH3	-	-	-	-	-	-	-
3	3	7	PTD1	ADC1_SE5	-	-	-	-	-	-	FCSPI1_SIN	-	-	FTU0_CH3/ FTU2_CH1	-	I2S0_MCLK	-	-	-	TRGSEL_OUT2	-
4	4	8	PTD0	ADC1_SE1	-	-	-	TRACE_D0	-	-	FCSPI1_SCK	-	-	FTU0_CH2/ FTU2_CH0	-	-	-	-	-	TRGSEL_OUT1	-
-	-	9	PTA22	-	-	-	-	-	-	-	-	-	-	FTU4_CH4	-	-	-	-	-	-	-
5	5	10	PTE11	ADC1_SE4	AONTIMERO_CLK1	-	-	-	-	-	FCSPI2_PCS0	-	-	FTU2_CH5	-	-	-	-	-	TRGSEL_OUT5	-

100LQFP	144LQFP	176LQFP-EP	Pin Name	Functions																	
				ADC	AONTIMER	CMP	ENET/MII	TRACE	EXTAL/XTAL	FCIIC	FCSPI	FCUART	FLEXCAN	FTU	FWM	I2S	JTAG/SWD/TRACE	OSC32K	OSPI	TRGSEL	RTC
6	6	11	PTE10	ADC1_SE0	-	-	-	-	-	-	FCSPI2_PCS1	-	FLEXCAN5_TX	FTU2_CH4	-	-	-	-	TRGSEL_OUT4	-	SCG_CLKOUT
7	7	12	PTE13	ADC0_SE5	-	-	-	-	-	-	FCSPI2_PCS2	-	FLEXCAN5_RX	FTU4_CH5	-	-	-	-	-	-	-
8	8	13	PTE5	ADC0_SE1	-	-	-	-	-	-	FCSPI1_SOUT	-	-	FTU_TCK2/FTU2_QD_PHA/FTU2_CH3	FWM_IN	-	-	-	-	-	-
9	9	14	PTE4	ADC0_SE4	-	-	-	TRACE_D1	-	-	FCSPI1_PCS0	-	-	FTU2_QD_PHB/FTU2_CH2	FWM_OUT_b	-	-	-	-	-	-
-	10	15	PTA25	ADC0_SE0	-	-	-	-	-	-	FCSPI2_SOUT	-	-	FTU5_CH0	-	-	-	-	-	-	-
-	-	16	PTB11	-	-	-	-	-	-	-	-	-	-	FTU6_CH0	-	-	-	-	-	-	-
10	11	17	VDDA	-	-	-	-	-	-	-	-	-	-	-	-	-	-	-	-	-	-
11	12	18	VREFH	-	-	-	-	-	-	-	-	-	-	-	-	-	-	-	-	-	-
12	13	19	VREFL	-	-	-	-	-	-	-	-	-	-	-	-	-	-	-	-	-	-
		20	VSSA	-	-	-	-	-	-	-	-	-	-	-	-	-	-	-	-	-	-
-	14	177	VSS	-	-	-	-	-	-	-	-	-	-	-	-	-	-	-	-	-	-
13	15	21	VDD_HV_A	-	-	-	-	-	-	-	-	-	-	-	-	-	-	-	-	-	-

100LQFP	144LQFP	176LQFP-EP	Pin Name	Functions																	
				ADC	AONTIMER	CMP	ENET/MII	TRACE	EXTAL/XTAL	FCIIC	FCSPI	FCUART	FLEXCAN	FTU	FWM	I2S	JTAG/SWD/TRACE	OSC32K	OSPI	TRGSEL	RTC
14	16	22	V11	-	-	-	-	-	-	-	-	-	-	-	-	-	-	-	-	-	-
15	17	23	V25	-	-	-	-	-	-	-	-	-	-	-	-	-	-	-	-	-	-
16	18	177	VSS	-	-	-	-	-	-	-	-	-	-	-	-	-	-	-	-	-	-
17	19	24	PTB7	-	-	-	-	-	EXTAL	FCIIC0_SCL	-	-	-	-	-	-	-	-	-	-	-
18	20	25	PTB6	-	-	-	-	-	XTAL	FCIIC0_SDA	-	-	-	-	-	-	-	-	-	-	-
-	21	26	PTA26	-	-	CMP0_IN0	-	-	-	-	FCSPI1_PCS0	-	-	FTU5_CH1	-	-	-	-	-	-	-
19	22	27	PTE14	-	AONTIMERO_CLK1	-	-	-	-	-	-	-	FLEXCAN0_RX	FTU2_CH7/FTU_FLT0	-	-	-	OSC32K_XTAL	-	-	-
20	23	28	PTE3	-	-	-	-	-	-	-	-	FCUART2_RX	-	FTU2_CH6/FTU_FLT1/FTU_TCK0	FWM_IN	-	-	OSC32K_EXTAL	-	TRGSEL_IN6	-
-	-	29	PTA23	-	-	-	-	-	-	-	-	FCUART3_RX	-	FTU4_CH6	-	-	-	-	-	-	-
-	-	30	PTA24	-	-	-	-	-	-	-	-	FCUART3_TX	-	FTU4_CH7	-	-	-	-	-	-	-
-	24	31	PTA27	ADC0_SE2	-	-	-	-	-	-	FCSPI1_SOUT	FCUART0_TX	FLEXCAN0_TX	FTU5_CH2	-	-	-	-	-	-	-
21	25	32	PTE12	ADC0_SE6	-	CMP0_OUTPUT	-	-	-	-	-	FCUART2_TX	-	FTU6_CH0/	-	-	-	-	-	-	-

100LQFP	144LQFP	176LQFP-EP	Pin Name	Functions																	
				ADC	AONTIMER	CMP	ENET/MII	TRACE	EXTAL/XTAL	FCIIC	FCSPI	FCUART	FLEXCAN	FTU	FWM	I2S	JTAG/SWD/TRACE	OSC32K	OSPI	TRGSEL	RTC
														FTU_FLT2							
-	26	33	PTA28	ADC0_SE3	-	-	-	-	-	-	FCSPI1_SCK	FCUART0_RX	FLEXCAN0_RX	FTU5_CH3	-	-	-	-	-	-	-
22	27	34	PTD17	ADC0_SE7	-	-	-	-	-	-	FCUART2_RX	-	FTU6_CH1/FTU_FLT3	-	-	-	-	-	-	-	-
-	28	35	PTA29	ADC0_SE8	-	-	-	-	-	-	FCSPI1_SIN	FCUART2_TX	-	FTU5_CH4	-	-	-	-	-	-	-
-	29	36	PTA30	ADC0_SE9	-	-	-	-	-	-	FCSPI0_SOU	FCUART2_RX	-	FTU5_CH5	-	-	-	-	-	-	-
23	30	37	PTD16	ADC0_SE10	-	-	-	TRACE_D2	-	-	FCSPI0_SIN	-	-	FTU0_CH1	-	-	-	-	-	-	-
24	31	38	PTD15	ADC0_SE11	-	CMP0_IN1	ENET_PPS2	TRACE_D3	-	-	FCSPI0_SCK	FCUART2_RTS	-	FTU0_CH0	-	-	-	-	-	-	-
25	32	39	PTE9	ADC0_SE12	-	CMP0_IN2	ENET_PPS3	TRACE_CLKOUT	-	-	FCSPI0_PCS0	FCUART2_CTS	-	FTU0_CH7	-	-	-	-	-	-	-
-	-	40	PTD14	-	-	-	-	-	-	-	-	-	-	FTU6_CH1	-	-	-	-	-	-	-
-	33	177	VSS	-	-	-	-	-	-	-	-	-	-	-	-	-	-	-	-	-	-
-	34	41	VDD_HV_A	-	-	-	-	-	-	-	-	-	-	-	-	-	-	-	-	-	-

100LQFP	144LQFP	176LQFP-EP	Pin Name	Functions																		
				ADC	AONTIMER	CMP	ENET/MII	TRACE	EXTAL/XTAL	FCIIC	FCSPI	FCUART	FLEXCAN	FTU	FWM	I2S	JTAG/SWD/TRACE	OSC32K	OSPI	TRGSEL	RTC	SCG
-	35	42	PTA31	ADC0_SE13	-	CMP0_IN3	-	-	-	-	FCSPI0_PCS1	-	FLEXCAN3_TX	FTU5_CH6	-	-	-	-	-	-	-	
-	36	43	PTB18	-	-	CMP0_IN4	-	-	-	-	FCSPI1_PCS1	-	FLEXCAN3_RX	FTU5_CH7	-	-	-	-	-	-	-	
-	-	44	PTB19	-	-	-	-	-	-	-	FCUART4_RX	-	-	FTU6_CH2	-	-	-	-	-	-	-	
-	37	45	PTB20	ADC0_SE14	-	-	ENET_PPS0	-	-	-	FCUART1_TX	-	-	FTU2_CH5	-	-	-	-	-	-	SCG_CLKOUT	
-	38	46	PTB21	ADC0_SE15	-	-	ENET_PPS1	-	-	-	FCUART1_RX	-	-	FTU2_CH4	-	-	-	-	-	-	RTC_CLKOUT	
-	-	47	PTB24	-	-	-	-	-	-	-	FCUART4_TX	-	-	FTU6_CH3	-	-	-	-	-	-	-	
26	39	48	PTE8	-	-	-	MII_RMII_DC	-	-	-	FCSPI0_SCK	-	-	FTU0_CH6	-	-	-	-	-	-	-	
27	40	49	PTB5	-	-	-	MII_RMII_DC	-	-	FCIIC1_SCL	FCSPI0_PCS0	-	-	FTU0_CH5	-	-	-	-	-	TRGSEL_IN0	-	SCG_CLKOUT
28	41	50	PTB4	-	-	-	MII_RMII_DIO	-	-	FCIIC1_SDA	FCSPI0_SOUT	-	-	FTU0_CH4	-	-	-	-	-	TRGSEL_IN1	-	-
-	-	51	PTB26	-	-	-	-	-	-	-	FCSPI3_SCK	-	-	FTU6_CH4	-	-	-	-	-	-	-	-

100LQFP	144LQFP	176LQFP-EP	Pin Name	Functions																	
				ADC	AONTIMER	CMP	ENET/MII	TRACE	EXTAL/XTAL	FCIIC	FCSPI	FCUART	FLEXCAN	FTU	FWM	I2S	JTAG/SWD/TRACE	OSC32K	OSPI	TRGSEL	RTC
-	-	52	PTB30	-	-	-	-	-	-	-	-	FCSPI3_SIN	-	-	FTU6_CH5	-	-	-	-	-	-
29	42	53	PTC3	-	-	CMP1_IN0	MII_TX_ER	-	-	-	-	-	FCUART0_TX	FLEXCAN0_TX	FTU0_CH3	-	-	-	-	-	-
30	43	54	PTC2	-	-	CMP1_IN1	MII_RX_D0	TRACE_CLKOUT	-	-	-	-	FCUART0_RX	FLEXCAN0_RX	FTU0_CH2	-	-	-	-	-	-
31	44	55	PTD7	-	-	CMP1_IN2	MII_TX_D1	TRACE_D0	-	-	-	FCSPI0_SIN	FCUART2_TX	FLEXCAN3_TX	-	-	-	-	-	-	-
32	45	56	PTD6	-	-	CMP1_IN3	MII_TX_D2	-	-	-	-	FCSPI3_SCK	FCUART2_RX	FLEXCAN3_RX	FTU_FLT4	-	-	-	-	OSPI_A_I00	-
33	46	57	PTD5	-	AONTIMER0_CLK2	-	MII_TX_D3	-	-	-	-	FCSPI3_SIN	-	-	FTU2_CH3/FTU_FLT5	-	-	-	-	OSPI_A_I01	TRGSEL_IN7
-	-	58	PTB2	-	-	-	-	-	-	-	-	-	-	-	FTU6_CH2	-	-	-	-	-	-
34	47	59	PTD12	-	-	-	MII_RX_MII_TX_EN	TRACE_D1	-	-	-	FCSPI3_SOUT	FCUART2_RTS	-	FTU2_CH2	-	-	-	-	OSPI_A_I07	-
35	48	60	PTD11	-	-	-	MII_RX_MII_TX_CLK	TRACE_D2	-	-	-	FCSPI3_PCS0	FCUART2_CTS	-	FTU2_CH1/FTU2_QD_PHA	-	-	-	-	-	-

100LQFP	144LQFP	176LQFP-EP	Pin Name	Functions																															
				ADC	AONTIMER	CMP	ENET/MII	TRACE	EXTAL/XTAL	FCIIC	FCSPI	FCUART	FLEXCAN	FTU	FWM	I2S	JTAG/SWD/TRACE	OSC32K	OSPI	TRGSEL	RTC	SCG													
36	49	61	PTD10	-	-	-	MII_RX_CLK	TRACE_D3	-	-	-	FCSPI3_PCS1	-	-	-	FTU2_CH0/ FTU2_QD_P HB	-	-	-	-	-	-	-	-	-	-	-	-	-	-	-	-	SCG_CL KOUT		
37	50	177	VSS	-	-	-	-	-	-	-	-	-	-	-	-	-	-	-	-	-	-	-	-	-	-	-	-	-	-	-	-	-			
38	51	62	VDD_H V_B	-	-	-	-	-	-	-	-	-	-	-	-	-	-	-	-	-	-	-	-	-	-	-	-	-	-	-	-	-	-		
39	52	63	V11	-	-	-	-	-	-	-	-	-	-	-	-	-	-	-	-	-	-	-	-	-	-	-	-	-	-	-	-	-	-		
-	-	64	PTB31	-	-	-	-	-	-	-	-	FCSPI3_SOUT	-	-	-	FTU7_CH7	-	-	-	-	-	-	-	-	-	-	-	-	-	-	-	-	-	-	
-	-	65	PTC18	-	-	-	-	-	-	-	-	FCSPI3_PCS0	-	-	-	FTU7_CH6	-	-	-	-	-	-	-	-	-	-	-	-	-	-	-	-	-	-	
40	53	66	PTC1	-	-	-	MII_R MII_RX D0	-	-	-	-	FCSPI2_SOUT	FCUART 3_TX	-	-	FTU0_CH1/ FTU1_CH7	-	-	-	-	-	-	-	-	-	-	-	-	-	-	-	-	-	-	OSPI_A_IO5
41	54	67	PTC0	-	-	-	MII_R MII_RX D1	-	-	-	-	FCSPI3_PCS2	-	-	-	FTU0_CH0/ FTU1_CH6	-	-	-	-	-	-	-	-	-	-	-	-	-	-	-	-	-	-	OSPI_A_IO6
42	55	68	PTD9	-	-	-	MII_RX D2	-	-	-	FCIIC1_SCL	FCSPI2_PCS1	FCUART 3_RX	-	-	FTU1_CH5	-	-	-	-	-	-	-	-	-	-	-	-	-	-	-	-	-	OSPI_A_SCK	
43	56	69	PTD8	-	-	-	MII_RX D3	-	-	-	FCIIC1_SDA	FCSPI2_PCS2	FCUART 4_RX	-	-	FTU1_CH4	-	-	-	-	-	-	-	-	-	-	-	-	-	-	-	-	-	OSPI_DQS_R WDS	
44	57	70	PTC17	-	-	-	MII_R MII_RX _DV	-	-	-	-	FCSPI2_PCS3	FCUART 4_TX	FLEXCAN2_TX	-	FTU_FLT6	-	-	-	-	-	-	-	-	-	-	-	-	-	-	-	-	-	-	

100LQFP	144LQFP	176LQFP-EP	Pin Name	Functions																	
				ADC	AONTIMER	CMP	ENET/MII	TRACE	EXTAL/XTAL	FCIIC	FCSPI	FCUART	FLEXCAN	FTU	FWM	I2S	JTAG/SWD/TRACE	OSC32K	OSPI	TRGSEL	RTC
45	58	71	PTC16	-	-	-	MII_RX_ER	-	-	-	FCSPI2_SIN	FCUART5_RX	FLEXCAN2_RX	FTU_FLT7	-	-	-	-	-	-	-
-	59	72	PTB22	-	-	CMP1_IN4	MII_CRS	-	-	-	FCSPI3_PCS3	FCUART1_TX	-	FTU_FLT8/FTU6_CH6	-	-	-	-	OSPI_A_IO2	-	-
46	60	73	PTC15	-	-	CMP1_IN5	MII_CRS	-	-	-	FCSPI2_SCK	FCUART5_TX	-	FTU1_CH3	-	-	-	-	OSPI_A_IO3	TRGSEL_IN8	-
-	61	74	PTB23	-	-	CMP1_IN6	MII_COL	-	-	-	-	FCUART1_RX	-	FTU_FLT9	-	-	-	-	OSPI_A_IO4	-	-
47	62	75	PTC14	-	-	CMP1_IN7	MII_COL	-	-	-	FCSPI2_PCS0	-	-	FTU1_CH2	-	-	-	-	OSPI_A_CS	TRGSEL_IN9	-
-	63	76	PTB25	-	-	-	-	-	-	-	FCSPI2_PCS0	-	-	FTU1_CH2/FTU6_CH7	-	-	-	-	-	-	-
48	64	77	PTB3	-	-	-	-	-	-	-	FCSPI0_SIN	-	-	FTU1_CH1/FTU1_QD_PHA	-	-	-	-	-	TRGSEL_IN2	-
-	65	78	PTB27	-	-	-	-	-	-	-	FCSPI2_SOUT	-	-	FTU7_CH5	-	-	-	-	-	-	-
-	66	79	PTB28	-	-	-	-	-	-	-	FCSPI2_SIN	-	-	FTU7_CH4	-	-	-	-	-	-	-

100LQFP	144LQFP	176LQFP-EP	Pin Name	Functions																		
				ADC	AONTIMER	CMP	ENET/MII	TRACE	EXTAL/XTAL	FCIIC	FCSPI	FCUART	FLEXCAN	FTU	FWM	I2S	JTAG/SWD/TRACE	OSC32K	OSPI	TRGSEL	RTC	SCG
-	-	80	PTD13	-	-	-	-	-	-	-	-	-	-	FTU6_CH3	-	-	-	-	-	-	-	-
-	67	177	VSS	-	-	-	-	-	-	-	-	-	-	-	-	-	-	-	-	-	-	-
-	68	81	VDD_H V_A	-	-	-	-	-	-	-	-	-	-	-	-	-	-	-	-	-	-	-
-	69	82	PTB29	-	-	-	-	-	-	-	FCSPI2_SCK	-	-	FTU1_CH0/ FTU1_QD_P HB	-	-	-	-	-	-	TRGSEL_IN3	-
49	70	83	PTC13	ADC1_SE15	-	CMP2_IN0	-	-	-	-	-	FCUART2_RTS	FLEXCAN5_TX	FTU3_CH7/ FTU2_CH7	-	-	-	-	-	-	TRGSEL_OUT6	-
50	71	84	PTC12	-	-	CMP2_IN1	-	-	-	-	-	FCUART2_CTS	FLEXCAN5_RX	FTU3_CH6/ FTU2_CH6	-	-	-	-	-	-	TRGSEL_OUT5	-
-	72	85	PTC19	-	-	CMP2_IN2	-	-	-	-	FCSPI2_PCS1	-	-	FTU7_CH3	-	-	-	-	-	-	-	-
-	-	86	PTC20	-	-	-	-	-	-	-	FCSPI2_SCK	-	-	FTU7_CH2	-	-	-	-	-	-	-	-
-	-	87	PTC21	-	-	-	-	-	-	-	FCSPI2_SIN	-	-	FTU7_CH1	-	-	-	-	-	-	-	-
-	-	88	PTC22	-	-	-	-	-	-	-	FCSPI2_SOUT	-	-	FTU7_CH0	-	-	-	-	-	-	-	-
-	73	89	PTC23	-	-	-	-	-	-	-	FCSPI0_SCK	-	-	-	-	-	-	-	-	-	-	-

100LQFP	144LQFP	176LQFP-EP	Pin Name	Functions																		
				ADC	AONTIMER	CMP	ENET/MII	TRACE	EXTAL/XTAL	FCIIC	FCSPI	FCUART	FLEXCAN	FTU	FWM	I2S	JTAG/SWD/TRACE	OSC32K	OSPI	TRGSEL	RTC	SCG
-	-	90	PTC24	-	-	-	-	-	-	-	FCSPI2_PCS0	-	-	FTU4_CH3	-	-	-	-	-	-	-	-
51	74	91	PTC11	-	-	-	-	-	-	-	FCSPI1_PCS0	-	FLEXCAN4_TX	FTU3_CH5/FTU4_CH2	-	-	-	-	-	-	TRGSEL_IN10	-
52	75	92	PTC10	ADC1_SE14	-	-	-	-	-	-	-	-	FLEXCAN4_RX	FTU3_CH4	-	-	-	-	-	-	TRGSEL_IN11	-
-	76	93	PTC27	-	-	-	-	-	-	-	-	-	-	FTU4_CH4	-	-	-	-	-	-	-	-
53	77	94	PTB1	ADC1_SE13	-	-	-	-	-	-	FCSPI0_SOUT	FCUART0_TX	FLEXCAN0_TX	FTU_TCK0/FTU4_CH5	-	-	-	-	-	-	-	-
54	78	95	PTB0	ADC1_SE12	AONTIMER0_CLK3	-	-	-	-	-	FCSPI0_PCS0	FCUART0_RX	FLEXCAN0_RX	FTU4_CH6	-	-	-	-	-	-	-	-
-	79	96	PTC28	-	-	-	-	-	-	-	-	-	FLEXCAN3_TX	FTU4_CH7	-	-	-	-	-	-	-	-
55	80	97	PTC9	-	-	CMP2_IN3	-	-	-	-	FCSPI1_SOUT	FCUART1_TX/FCUART0_RTS	-	FTU_FLT10/FTU5_CH0	-	-	-	-	-	-	-	-
56	81	98	PTC8	-	-	CMP2_IN4	-	-	-	-	FCSPI1_SIN	FCUART1_RX/FCUART0_CTS	-	FTU_FLT11/FTU5_CH1	-	-	-	-	-	-	-	-

100LQFP	144LQFP	176LQFP-EP	Pin Name	Functions																	
				ADC	AONTIMER	CMP	ENET/MII	TRACE	EXTAL/XTAL	FCIIC	FCSPI	FCUART	FLEXCAN	FTU	FWM	I2S	JTAG/SWD/TRACE	OSC32K	OSPI	TRGSEL	RTC
-	82	99	PTC29	-	-	-	-	-	-	-	-	-	FLEXCAN3_RX	FTU5_CH2	-	-	-	-	-	-	-
57	83	100	PTA7	-	-	CMP2_IN5	-	-	-	-	-	FCSPI1_SCK	FCUART1_RTS	-	FTU_FLT12/FTU5_CH3	-	-	-	-	-	-
-	84	101	PTC30	ADC1_SE11	-	-	-	-	-	-	-	-	-	-	FTU5_CH4	-	-	-	-	-	-
58	85	102	PTA6	ADC1_SE10	-	-	-	-	-	-	-	FCSPI1_PCS1	FCUART1_CTS	-	FTU_FLT13/FTU5_CH5	-	-	-	-	-	TRGSEL_OUT4
-	86	103	PTC31	-	-	-	-	-	-	FCIIC1_SDA	-	-	-	-	FTU5_CH6	-	-	-	-	-	-
59	87	104	PTE7	ADC1_SE9	-	-	-	-	-	-	-	-	-	-	FTU0_CH7/FTU_FLT14	-	-	-	-	-	TRGSEL_OUT3
-	88	105	PTD18	ADC1_SE8	-	-	-	-	-	-	-	-	-	-	FTU5_CH7	-	-	-	-	-	-
-	89	106	PTD19	-	-	-	-	-	-	FCIIC1_SCL	-	-	-	-	FTU6_CH0	FWM_OUT_b	-	-	-	-	-
-	-	107	PTE28	-	-	-	-	-	-	-	-	-	-	-	FTU6_CH4	-	-	-	-	-	SCG_CLKOUT
60	90	177	VSS	-	-	-	-	-	-	-	-	-	-	-	-	-	-	-	-	-	-
61	91	108	VDD_HV_A	-	-	-	-	-	-	-	-	-	-	-	-	-	-	-	-	-	-

100LQFP	144LQFP	176LQFP-EP	Pin Name	Functions																		
				ADC	AONTIMER	CMP	ENET/MII	TRACE	EXTAL/XTAL	FCIIC	FCSPI	FCUART	FLEXCAN	FTU	FWM	I2S	JTAG/SWD/TRACE	OSC32K	OSPI	TRGSEL	RTC	SCG
62	92	109	PTA17	-	-	-	-	-	-	-	-	-	FLEXCAN4_TX	FTU0_CH6/FTU_FLT15	FWM_OUT_b	-	-	-	-	-	-	
63	93	110	PTB17	-	-	-	-	-	-	-	FCSPI1_PCS3	-	FLEXCAN4_RX	FTU0_CH5	-	-	-	-	TRGSEL_OUT3	-	-	
64	94	111	PTB16	ADC1_SE16	-	-	-	-	-	-	FCSPI1_SOUT	-	-	FTU0_CH4	-	-	-	-	-	-	-	
65	95	112	PTB15	ADC1_SE17	-	-	-	-	-	-	FCSPI1_SIN	-	-	FTU0_CH3	-	-	-	-	-	-	-	
66	96	113	PTB14	ADC1_SE18	-	-	-	-	-	-	FCSPI1_SCK	-	-	FTU0_CH2	-	-	-	-	-	-	-	
67	97	114	PTB13	ADC1_SE19	-	-	-	-	-	-	-	-	FLEXCAN2_TX	FTU0_CH1	-	-	-	-	-	-	-	
68	98	115	PTB12	ADC1_SE20	-	-	-	-	-	-	-	-	FLEXCAN2_RX	FTU0_CH0	-	-	-	-	-	-	-	
-	99	116	PTD22	ADC1_SE21	-	-	-	-	-	-	-	-	-	FTU6_CH1	-	I2S1_D3	-	-	-	-	-	
-	-	117	PTC25	-	-	-	-	-	-	-	-	FCUART5_RTS	-	FTU4_CH1	-	-	-	-	-	-	-	
-	-	118	PTC26	-	-	-	-	-	-	-	-	FCUART5_CTS	-	FTU4_CH0	-	-	-	-	-	-	-	
-	-	119	PTD20	-	-	-	-	-	-	-	-	FCUART5_RX	-	FTU6_CH2	-	-	-	-	-	-	-	
-	-	120	PTD21	-	-	-	-	-	-	-	-	FCUART5_TX	-	FTU6_CH3	-	-	-	-	-	-	-	

100LQFP	144LQFP	176LQFP-EP	Pin Name	Functions																		
				ADC	AONTIMER	CMP	ENET/MII	TRACE	EXTAL/XTAL	FCIIC	FCSPI	FCUART	FLEXCAN	FTU	FWM	I2S	JTAG/SWD/TRACE	OSC32K	OSPI	TRGSEL	RTC	SCG
69	100	121	PTD4	ADC1_SE22	-	CMP2_IN6	-	-	-	-	-	-	-	-	FTU_FLT16/FTU6_CH4	-	-	-	-	-	-	
70	101	122	PTD3	ADC1_SE23	-	-	-	-	-	-	FCSPI1_PCS0	-	-	-	FTU3_CH5	-	-	-	-	-	TRGSEL_IN4	
71	102	123	PTD2	ADC0_SE24	-	-	-	-	-	-	-	-	-	-	FTU3_CH4	-	-	-	-	-	TRGSEL_IN5	
-	103	124	PTD23	ADC0_SE25	-	CMP2_IN7	-	-	-	-	-	-	-	-	FTU6_CH5	-	I2S1_D2	-	-	-	-	
72	104	125	PTA3	ADC0_SE26	-	-	-	-	-	FCIIC0_SCL	-	FCUART0_TX	-	-	FTU3_CH1	FWM_IN	-	-	-	-	-	
73	105	126	PTA2	ADC0_SE27	-	-	-	-	-	FCIIC0_SDA	-	FCUART0_RX	-	-	FTU3_CH0	FWM_OUT_b	-	-	-	-	-	
-	106	127	PTD24	ADC0_SE31/ADC1_SE31	-	CMP2_OUTPUT	-	-	-	-	-	-	-	-	FTU3_CH3	-	I2S1_D1	-	-	-	-	
-	-	128	PTE31	-	-	-	-	-	-	-	-	-	-	-	FTU6_CH5	-	-	-	-	-	-	
-	-	177	VSS	-	-	-	-	-	-	-	-	-	-	-	-	-	-	-	-	-	-	
-	-	129	VDD_HV_A	-	-	-	-	-	-	-	-	-	-	-	-	-	-	-	-	-	-	
74	107	130	PTB10	-	-	-	-	-	-	-	-	-	-	FLEXCAN0_TX	FTU3_CH2/FTU2_QD_PHA	-	I2S1_MCLK	-	-	-	-	TRGSEL_OUT2

100LQFP	144LQFP	176LQFP-EP	Pin Name	Functions																	
				ADC	AONTIMER	CMP	ENET/MII	TRACE	EXTAL/XTAL	FCIIC	FCSPI	FCUART	FLEXCAN	FTU	FWM	I2S	JTAG/SWD/TRACE	OSC32K	OSPI	TRGSEL	RTC
-	-	131	PTD25	-	-	-	-	-	-	-	-	FCUART4_RTS	-	FTU6_CH6	-	-	-	-	-	-	-
75	108	132	PTB9	ADC0_SE30/ ADC1_SE30	-	-	-	-	-	-	-	-	-	FTU3_CH1	-	I2S1_DO	-	-	-	TRGSEL_OUT1	-
-	-	133	PTD26	-	-	-	-	-	-	-	-	FCUART4_CTS	-	FTU6_CH7	-	-	-	-	-	-	-
-	109	134	PTD27	-	-	-	-	-	-	-	-	-	FLEXCAN4_TX	FTU7_CH0	-	-	-	-	-	-	-
76	110	135	PTB8	ADC0_SE29/ ADC1_SE29	-	CMP2_OUTPUT	-	-	-	-	-	FCUART1_CTS	FLEXCAN0_RX	FTU3_CH0	-	I2S1_BLOCK	-	-	-	-	-
-	111	136	PTD28	-	-	-	-	-	-	-	-	-	FLEXCAN4_RX	FTU7_CH1	-	-	-	-	-	-	-
77	112	137	PTA1	ADC0_SE28/ ADC1_SE28	-	-	-	-	-	-	-	FCUART0_RTS	-	FTU1_CH1/ FTU1_QD_PHA	-	-	-	-	-	TRGSEL_OUT0	-
-	113	138	PTD29	ADC1_SE27	-	-	-	-	-	-	-	-	FLEXCAN5_RX	FTU7_CH2	-	-	-	-	-	-	-

100LQFP	144LQFP	176LQFP-EP	Pin Name	Functions																		
				ADC	AONTIMER	CMP	ENET/MII	TRACE	EXTAL/XTAL	FCIIC	FCSPI	FCUART	FLEXCAN	FTU	FWM	I2S	JTAG/SWD/TRACE	OSC32K	OSPI	TRGSEL	RTC	SCG
78	114	139	PTA0	ADC1_SE26	-	-	-	-	-	-	-	FCUART0_CTS	-	FTU2_CH1/FTU2_QD_PHA	-	-	-	-	-	TRGSEL_OUT3	-	-
-	115	140	PTD30	ADC1_SE25	-	-	-	-	-	-	-	-	FLEXCAN5_TX	FTU7_CH3	-	-	-	-	-	-	-	-
-	-	141	PTD31	-	-	-	-	-	-	-	-	-	-	FTU7_CH4	-	-	-	-	-	-	-	-
79	116	142	PTC7	ADC1_SE24	-	-	-	-	-	-	-	FCUART1_TX	FLEXCAN1_TX	FTU3_CH3/FTU1_QD_PHA	-	-	-	-	-	-	-	-
80	117	143	PTC6	ADC0_SE23	-	-	-	-	-	-	-	FCUART1_RX	FLEXCAN1_RX	FTU3_CH2/FTU1_QD_PHB	-	-	-	-	-	-	-	-
-	-	144	PTE17	-	-	-	-	-	-	-	-	-	-	FTU7_CH5	-	-	-	-	-	-	-	-
81	118	145	PTA16	ADC0_SE22	-	-	-	-	-	-	FCSPI1_PCS2	-	FLEXCAN3_TX	FTU1_CH3	-	-	-	-	-	-	-	-
-	-	146	PTE18	-	-	-	-	-	-	-	-	-	-	FTU7_CH6	-	-	-	-	-	-	-	-
82	119	147	PTA15	ADC0_SE21	-	-	-	-	-	-	FCSPI2_PCS3	-	FLEXCAN3_RX	FTU1_CH2	-	-	-	-	-	TRGSEL_OUT0	-	-

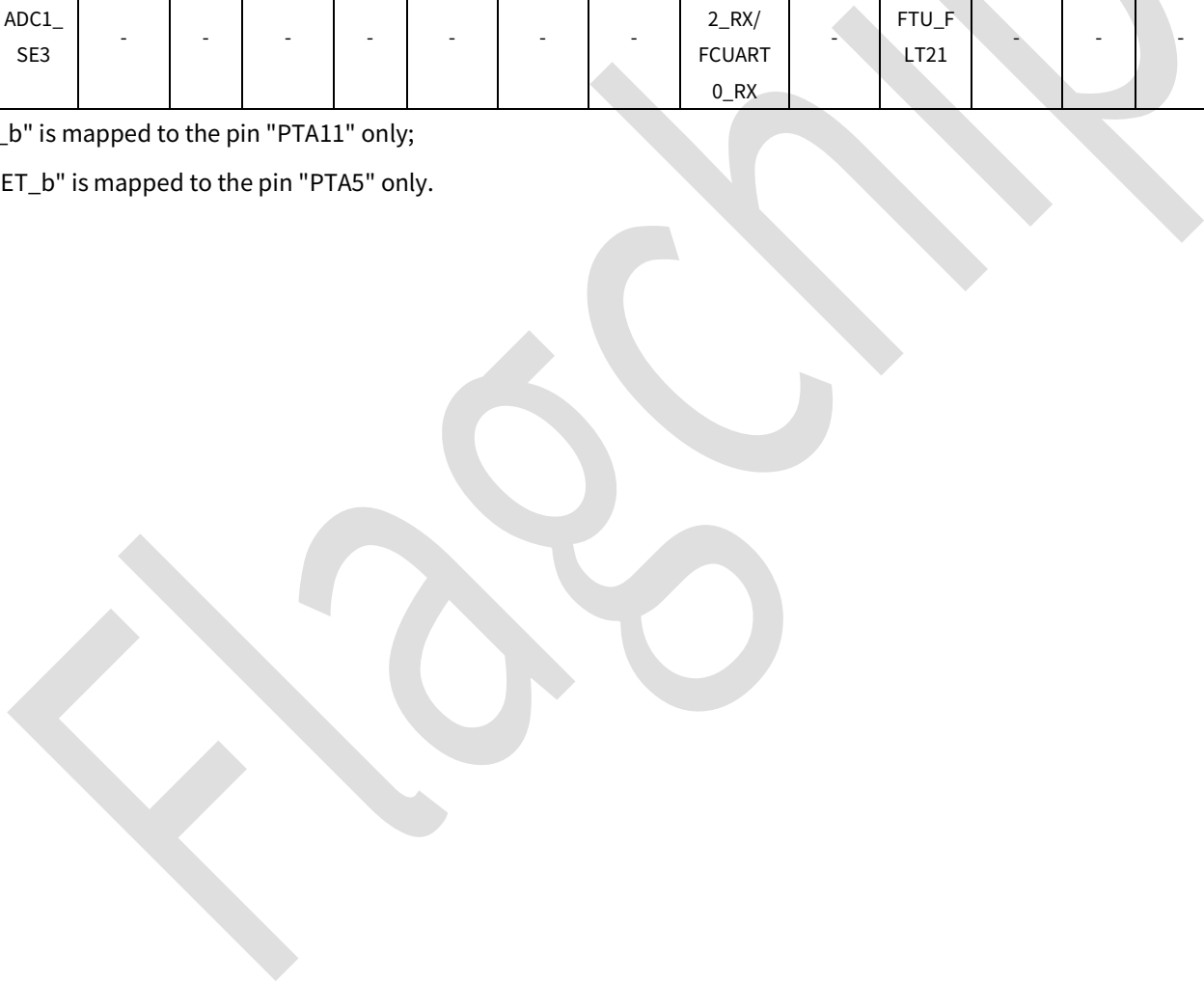
100LQFP	144LQFP	176LQFP-EP	Pin Name	Functions																		
				ADC	AONTIMER	CMP	ENET/MII	TRACE	EXTAL/XTAL	FCIIC	FCSPI	FCUART	FLEXCAN	FTU	FWM	I2S	JTAG/SWD/TRACE	OSC32K	OSPI	TRGSEL	RTC	SCG
83	120	148	PTE6	ADC0_SE20	-	CMP1_OUTPUT	-	-	-	-	-	FCUART1_RTS	-	FTU7_CH7/FTU3_CH7	-	-	-	-	-	-	-	
84	121	149	PTE2	ADC0_SE19	AONTIMERO_CLK3	-	-	-	-	-	-	FCUART1_CTS	-	FTU3_CH6	-	-	I2S1_SYNC	-	-	-	-	
-	-	150	PTE30	-	-	-	-	-	-	-	-	-	-	FTU6_CH6	-	-	-	-	-	-	-	
85	122	177	VSS	-	-	-	-	-	-	-	-	-	-	-	-	-	-	-	-	-	-	
86	123	151	VDD_HV_A	-	-	-	-	-	-	-	-	-	-	-	-	-	-	-	-	-	-	
87	124	152	V11	-	-	-	-	-	-	-	-	-	-	-	-	-	-	-	-	-	-	
-	125	153	PTE19	ADC0_SE18	-	-	-	-	-	-	FCIIC0_SCL	-	-	-	-	-	-	-	-	-	TRGSEL_IN12	SCG_CLKOUT
-	126	154	PTE20	ADC0_SE17	-	-	-	-	-	-	FCIIC0_SDA	-	-	FTU4_CH0	-	-	-	-	-	-	-	-
88	127	155	PTA14	-	AONTIMERO_CLK2	-	-	-	-	-	-	FCUART0_TX	-	FTU_FLT17	FWM_IN	I2S0_D3	-	-	-	-	TRGSEL_IN13	-
-	128	156	PTE21	ADC0_SE16	AONTIMERO_CLK3	-	-	-	-	-	-	FCUART0_RTS	FLEXCAN0_TX	FTU4_CH1	-	-	-	-	-	-	-	-
-	129	157	PTE22	-	-	-	-	-	-	-	-	FCUART0_CTS	FLEXCAN0_RX	FTU4_CH2	-	-	-	-	-	-	-	-

100LQFP	144LQFP	176LQFP-EP	Pin Name	Functions																	
				ADC	AONTIMER	CMP	ENET/MII	TRACE	EXTAL/XTAL	FCIIC	FCSPI	FCUART	FLEXCAN	FTU	FWM	I2S	JTAG/SWD/TRACE	OSC32K	OSPI	TRGSEL	RTC
89	130	158	PTA13	-	-	CMP1_OUT	-	-	-	-	-	FCUART0_RX	FLEXCAN1_TX	FTU1_CH7/ FTU2_QD_PHA	-	I2S0_DO	-	-	-	-	-
-	131	159	PTE23	-	-	-	-	-	-	-	FCSPI0_PCS3	-	-	FTU4_CH3	-	-	-	-	-	-	-
-	132	160	PTE24	-	-	-	-	-	-	-	FCSPI0_PCS2	-	FLEXCAN2_TX	FTU4_CH4	-	-	-	-	-	-	-
-	133	161	PTE25	-	-	-	-	-	-	-	FCSPI0_PCS1	-	FLEXCAN2_RX	FTU4_CH5	-	-	-	-	-	-	-
90	134	162	PTA12	-	-	CMP2_OUT	-	-	-	-	FCSPI0_SOUT	-	FLEXCAN1_RX	FTU1_CH6/ FTU2_QD_PHB	-	I2S0_BCLK	-	-	-	-	-
91	135	163	PTA11 ¹	-	-	-	-	-	-	-	FCSPI0_PCS0	-	-	FTU1_CH5	-	I2S0_SYNC	-	-	-	-	-
92	136	164	PTA10	-	AONTIMERO_CLK1	-	-	-	-	-	FCIIC0_SCL	-	-	FTU1_CH4	-	-	JTAG_TDO/T RACE_SWO	-	-	-	-
93	137	165	PTE1	-	-	-	-	-	-	FCIIC1_SCL	FCSPI0_SIN	FCUART0_RTS	-	FTU_FLT18	-	I2S0_D1	-	-	-	-	-
94	138	166	PTE0	-	-	-	-	-	-	FCIIC1_SDA	FCSPI0_SCK	FCUART0_CTS	-	FTU_TCK1/	-	I2S0_D2	-	-	-	-	-

100LQFP	144LQFP	176LQFP-EP	Pin Name	Functions																	
				ADC	AONTIMER	CMP	ENET/MII	TRACE	EXTAL/XTAL	FCIIC	FCSPI	FCUART	FLEXCAN	FTU	FWM	I2S	JTAG/SWD/TRACE	OSC32K	OSPI	TRGSEL	RTC
														FTU_FLT19							
-	-	167	PTE26	-	-	-	-	-	-	-	-	-	-	FTU4_CH6	-	-	-	-	-	-	-
95	139	168	PTC5	-	-	CMP1_OUTPUT	-	-	-	FCIIC0_SDA	-	-	-	FTU2_CH0/FTU2_QD_P HB	-	-	JTAG_TDI	-	-	-	RTC_CLKOUT
96	140	169	PTC4	-	-	-	-	-	-	-	-	-	-	FTU1_CH0/FTU1_QD_P HB	FWM_IN	-	JTAG_TCLK/SWD_CLK	-	-	TRGSEL_IN14	RTC_CLKOUT
97	141	170	PTA5 ²	-	-	-	-	-	-	-	-	-	-	-	-	-	-	-	-	-	-
-	-	171	PTE29	-	-	-	-	-	-	-	-	-	-	FTU2_CH0	-	-	-	-	-	-	-
-	-	177	VSS	-	-	-	-	-	-	-	-	-	-	-	-	-	-	-	-	-	-
-	-	172	VDD_HV_A	-	-	-	-	-	-	-	-	-	-	-	-	-	-	-	-	-	-
98	142	173	PTA4	-	-	CMP0_OUTPUT	-	-	-	-	-	-	-	-	FWM_OUT_b	-	JTAG_TMS/SWD_DIO	-	-	TRGSEL_OUT7	-
-	-	174	PTE27	-	-	-	-	-	-	-	-	-	-	FTU4_CH7	-	-	-	-	-	-	-
99	143	175	PTA9	ADC1_SE7	-	-	-	-	-	-	-	FCUART2_TX/FCUART0_TX	-	FTU_FLT20	-	I2S0_MCLK	-	-	-	-	-

100LQFP	144LQFP	176LQFP-EP	Pin Name	Functions																	
				ADC	AONTIMER	CMP	ENET/MII	TRACE	EXTAL/XTAL	FCIIC	FCSPI	FCUART	FLEXCAN	FTU	FWM	I2S	JTAG/SWD/TRACE	OSC32K	OSPI	TRGSEL	RTC
100	144	176	PTA8	ADC1_SE3	-	-	-	-	-	-	-	FCUART2_RX/ FCUART0_RX	-	FTU_FLT21	-	-	-	-	-	-	-

Note: 1. The function "NMI_b" is mapped to the pin "PTA11" only;
 2. The function "RESET_b" is mapped to the pin "PTA5" only.



Revision History

Revision	Date	Changes
A0	2023/03/30	PPAP release
A1	2023/11/28	<ul style="list-style-type: none"> • Added FC4150F1M_A-related specifications; • In <i>Chapter 1 Introduction</i>: <ul style="list-style-type: none"> - Updated <i>Figure 1. Ordering information</i> and the Note in <i>Section 1.1.1 Ordering Information</i>; - Updated the description in <i>Section 1.1.2 Orderable Part Number</i>; - Added a new section <i>Marking Rule</i>. • Added qualification-related descriptions to <i>Chapter 2 Features</i>; • In <i>Table 1. Absolute maximum ratings</i> in <i>Section 3.1 Absolute Maximum Ratings</i>: <ul style="list-style-type: none"> - Changed the Max. data for "VDD_HV_A", "VDD_HV_B", "VREFH" and "VIN_DC" from "5.8" to "6.0"; - Updated the Note. • In <i>Chapter 11 Pinout</i>: <ul style="list-style-type: none"> - Updated figures for 176LQFP-EP, 144LQFP, and 100LQFP; - Fixed typos by removing "FTU1_CH2" and "FTU1_CH1" for both 144LQFP (67, 68) and 176LQFP (177, 81). • Replaced the attachment <i>FC4150_Family_Orderable_Part_Number_List</i> with a new one <i>FC4150F2M_and_FC4150F1M_A_Orderable_Part_Number_List_A1</i>
A2	2024/05/10	<ul style="list-style-type: none"> • Replaced "FRO" with "FIRC" in the block diagrams in <i>Chapter 2 Features</i>; • In <i>Chapter 3 General</i>: <ul style="list-style-type: none"> - Added the Max. value "0.1" for V_{HYS} to <i>Table 5. LVR/LVD/HVD and POR</i> in <i>Section 3.5 LVR, LVD, HVD, and POR Operating Requirements</i>; - Changed the Typ. value for "Standby Mode, no RAM retention, SIRC12M Enable, 25°C" from "145" to "162.0" in <i>Table 8. Chip Low Power IDD</i>; - Added the Max. values to both <i>Table 7. Chip RUN IDD</i> and <i>Table 8. Chip Low Power IDD</i> in <i>Section 3.7 Chip IDD</i>; - Updated the notes for <i>Table 11. ESD ratings</i> in <i>Section 3.9 ESD Ratings</i>. • Added the "Symbol" column to both <i>Table 16. FOOSC Specification</i> and <i>Table 17. SOSOC Specification</i> in <i>Chapter 5 Clock Specification</i>; • Changed "page" into "word" for program time in <i>Table 23. FC4150F2M NVM program/erase time</i> and <i>Table 24. FC4150F1M_A NVM program/erase time</i> in <i>Section 6.2 NVM Program/Erase Time</i>; • In <i>Chapter 7 Analog</i>: <ul style="list-style-type: none"> - In <i>Table 25. ADC specification of Section 7.1 12-bit SAR ADC</i>: <ul style="list-style-type: none"> ■ Changed the Typ. value of Conversion Cycles from "12" to "14"; ■ Changed the Max. value of Conversion Rate from "1" to "1.6"; ■ Added a note for the formula for calculating the max. conversion rate. - In <i>Table 26. CMP specification of Section 7.2 CMP Specification</i>: <ul style="list-style-type: none"> ■ Added the Max. value "±3" for INL;

		<ul style="list-style-type: none">■ Changed the Typ. value for DNL from "± 1" to "± 0.5", and added the Max. value "± 1".• Added a row "3.0 - 3.6 V" to <i>Table 32. OSPI timing in Section 8.4 OSPI Specification</i>;• Replaced "ETM_TRACE" with "TRACE" in <i>Table 37. FC4150F2M and FC4150F1M_A pin functions in Chapter 11 Pinout</i>;• Editorial changes
--	--	---

Contact Us

Headquarters:

Room 213, 2nd Floor, Suite Z104, Building
2, NO.78, East Jinshan RD, New District,
Suzhou, Jiangsu 215011, P.R. China

Website: www.flagchip.com.cn

TEL: +86-512-66166689

Disclaimer

This document is the property of the Suzhou Flagchip Semiconductor Co., Ltd. (hereinafter referred to as "Flagchip"). Any information provided in this document is only for reference purposes.

Except as expressly provided herein, no part of this document may be reproduced, stored in a retrieval system, or transmitted in any form or by any means, electronic, mechanical, photocopying, recording, or otherwise, without the prior written permission of Flagchip. Flagchip hereby disclaims any responsibilities for any losses, expenses, claims, damages, and liabilities related to the use of the information. All information described herein is subject to change without further notice.

ARM and Cortex are registered trademarks of ARM Limited. All other trademarks mentioned in this document are the property of their respective owners.

单击下面可查看定价，库存，交付和生命周期等信息

[>>Flagchip\(旗芯微\)](#)