



GSV6712 Product Brief

2 In to 1 Out HDMI 2.1/Type-C DisplayPort 1.4 to HDMI 2.1 Mixed Switch with Embedded MCU

General Description

Gscoolink GSV6712 is a high-performance, low-power 2 In to 1 Out HDMI 2.1/DisplayPort 1.4 to HDMI 2.1 mixed switch. By integrating enhanced microcontroller based on RISC-V, GSV6712 has created a cost-effective solution that provides time-to-market advantages. The DisplayPort Receiver supports up to 32.4Gbps (HBR3, 4-lane), HDMI Receiver and HDMI Transmitter supports up to 48Gbps (FRL, 12G/4Lane). With embedded Channel Configuration (CC), Power Delivery (PD) controller and Billboard USB 2.0 controller, GSV6712 can directly map its one receiver to USB Type-C interface, and Alternate DisplayPort for Type-C can be supported for Type-C to HDMI application. The superior architecture of GSV6712 provides economical smaller footprint solutions using QFN88, targeting applications of TV/Monitor/Sound bar/Stream box and KVM.

DisplayPort Receiver Features

- Compliant with VESA DisplayPort 1.4a
- Compliant with HDCP 2.2/2.3 and HDCP 1.4
- Compliant with both DisplayPort and USB Type-C Alternative Mode
- Support HBR3, HBR2, HBR and RBR (8.1/5.4/2.7/1.62 Gbps)
- Flexible 1/2/4 lane Main-Link configuration
- Programmable Adaptive Equalization
- Support Full-Link Training and No-Link Training
- Support High Dynamic Range (HDR) and Dynamic/Static Metadata
- Support Adaptive Sync/FreeSync/G-Sync to HDMI VRR output conversion
- Support Audio Extraction
- Support Horizontal Blanking Expansion up to 4K120 format
- Support Forward Error Correction (FEC)
- Embedded arbitrary EDID and MCCS
- Support Spread Spectrum Clock (SSC)
- Support DSC bypass to HDMI output

HDMI Receiver Features

- Compliant with HDMI 2.1, HDMI 2.0b, HDMI 1.4b
- Compliant with HDCP 2.2/2.3 and HDCP 1.4 in repeater/receiver mode
- Data rate up to 48Gbps (FRL 12Gbps/4 Lane)
- Programmable Adaptive Equalization

- Support High Dynamic Range (HDR) and Dynamic/Static Metadata
- Support Variable Refresh Rate (VRR), FreeSync, G-Sync
- Support ALLM
- Support Forward Error Correction (FEC)
- Support DSC pass-through for compressed input timing
- Embedded arbitrary EDID (up to 512 bytes)
- 5V tolerance on DDC/HPD pins

HDMI Transmitter Features

- Compliant with HDMI 2.1a, HDMI 2.0b, HDMI 1.4b
- Compliant with HDCP 2.2/2.3 and HDCP 1.4
- Data rate up to 48Gbps (FRL 12Gbps/4 Lane)
- Programmable Voltage Swing, Slew-Rate and Pre-emphasis
- Support AC-coupling on TMDS input/output
- Support Color Space Converter in TMDS mode
- Support HDR (HDR10/HDR10+/Dolby Vision/HLG)
- Support Variable Refresh Rate (VRR), FreeSync, G-Sync
- Support ALLM
- Support DSC encoded stream pass-through from HDMI/DP input
- Hardware CEC Engine for Low Level protocol decoding
- 5V tolerance on DDC/HPD/CEC pins
- Support eARC Rx to I2S/SPDIF audio extraction in HDMI 2.1a

USB Type-C Alternative Mode Features

- Compliant with USB Type-C 1.1/1.0 Specification
- Compliant with USB Power Delivery 3.0 Specification
- Programmable USB Type-C Channel Configuration function
- Support Billboard in USB 2.0

Audio Input/Output Features

- I2S and SPDIF Audio Extraction from HDMI Rx
- I2S and SPDIF Audio Extraction from downstream ARC /eARC
- I2S/SPDIF Audio Insertion to HDMI Tx
- SPDIF/I2S/HBR/DSD/TDM Format Supported for Audio Extraction and Insertion
- SPDIF to I2S Conversion using single Bi-directional TTL bus

System Features

- Optional External MCU (via I2C)/ Internal MCU mode
- Embedded MCU and External Flash
- External pins of Flash QSPI interface
- External 25MHz Crystal required
- Available Pins for UART/Timer/GPIO control from
- embedded MCU
- Mailbox feature for external MCU access on chip function status
- Temperature Sensor Monitoring Circuit

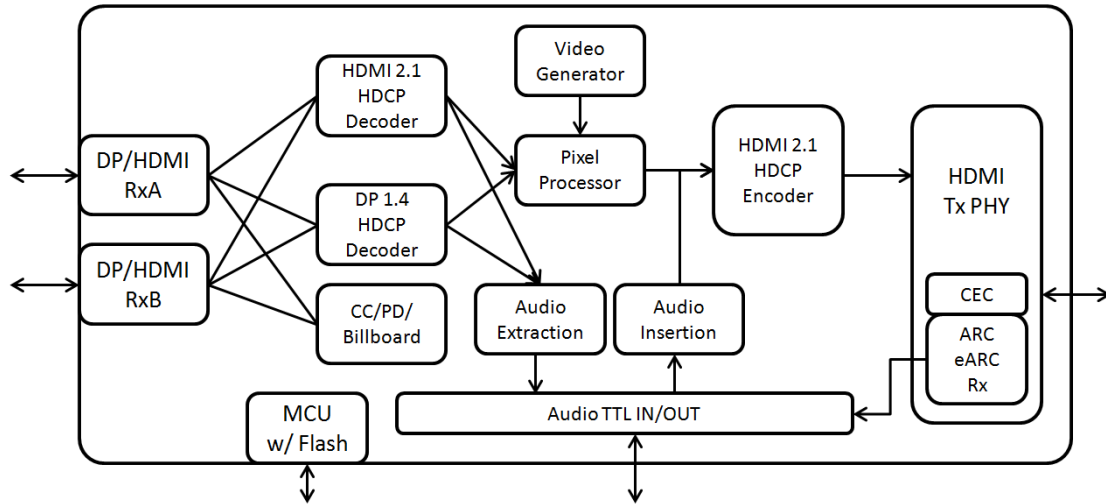

Pin Description

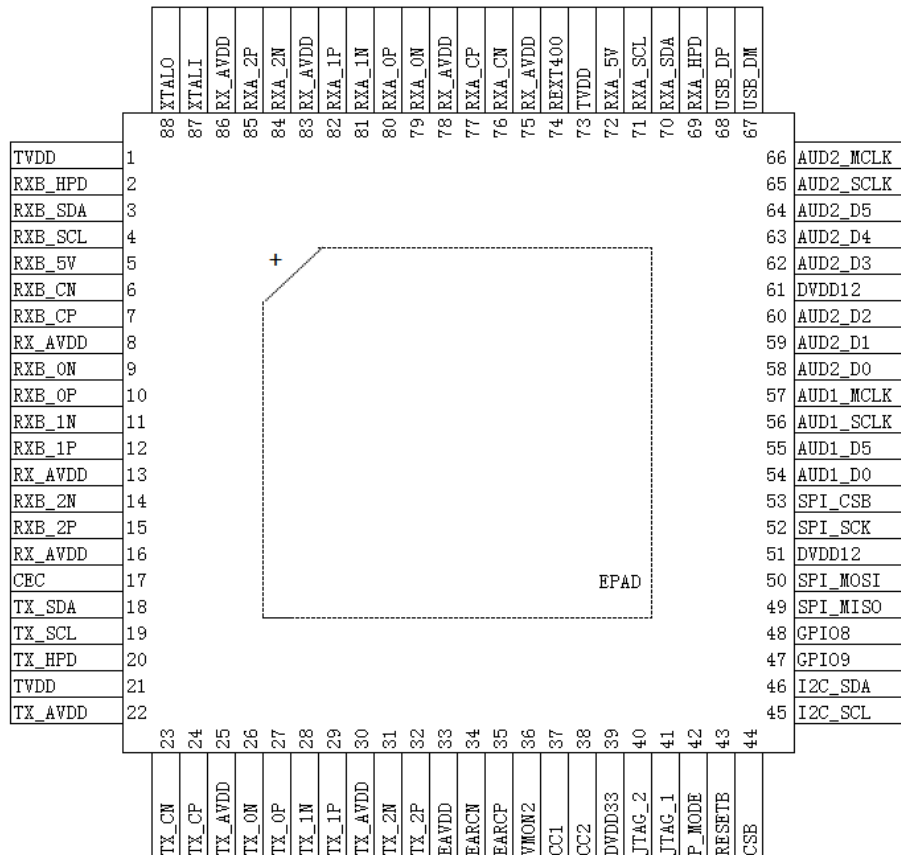

GSV6712 QFN88 Pin Diagram

Package Information

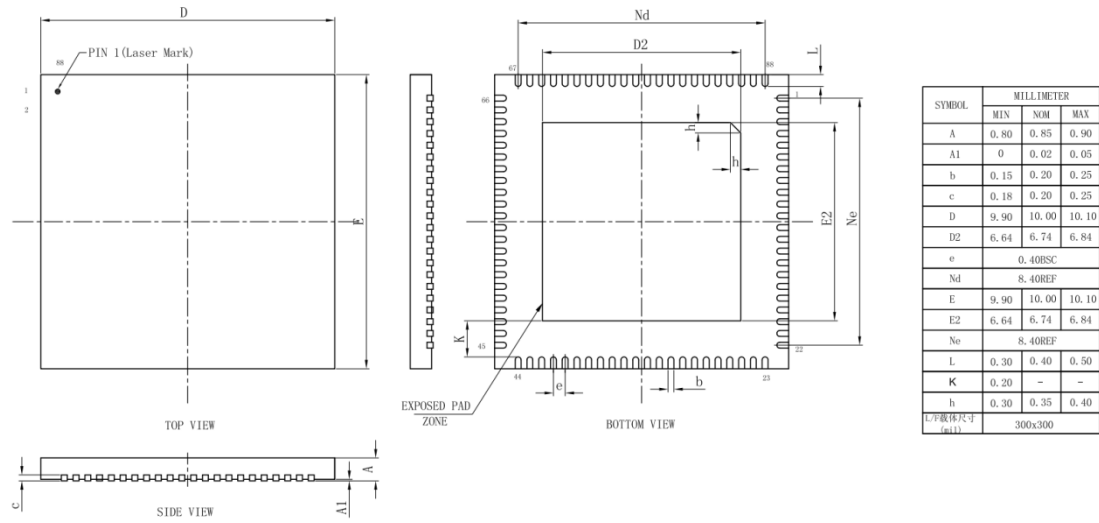

Package Dimensions (QFN88)

单击下面可查看定价，库存，交付和生命周期等信息

[>>GScoolink\(基石酷联\)](#)