



SY59101N

**Dimmable, high Efficiency Linear Driver
With Integrated 350V MOSFET**
Preliminary Specification

General Description

The SY59101N is a linear AC/DC driver with integrated 350V MOSFET for LED lighting. It's compatible with Leading/Trailing edge dimmer. The patented technique results in high efficiency and power factor.

Ordering Information

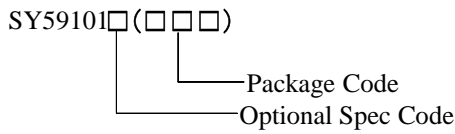

Ordering Number	Package type	Note
SY59101NFCP	SO8E	----

Features

- Compatible with Leading/Trailing Edge Dimmer
- Integrated 350V MOSFET
- Power Factor >0.7
- Good Regulation($\pm 3\%$)
- Up to 85% High Efficiency
- SMT Assembly
- Eliminate Magnetic Components
- Compact Package: SO8E

Applications

- LED Lighting
- Down Light/Bulb/Spot Lamp

Typical Applications

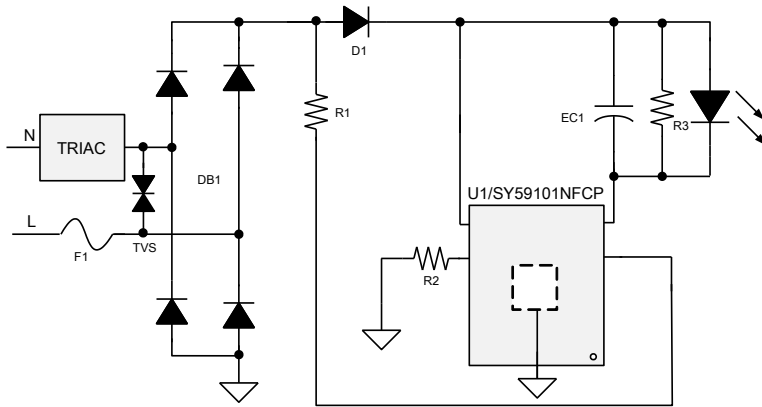
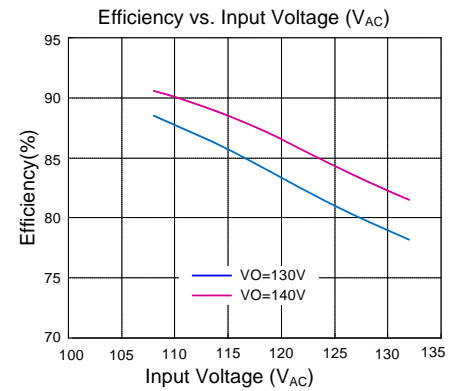
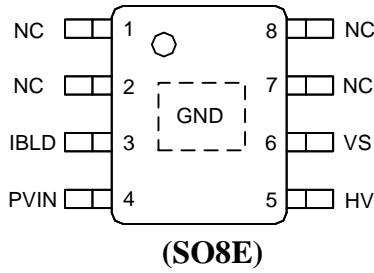

Fig1. Typical application



Pinout (top view)



Top Mark: DNExyz (device code: DNE, *x*=year code, *y*=week code, *z*= lot number code)

Pin	Name	Description
1,2,7,8	NC	No connect
3	IBLD	Bleeding current from BUS to achieve good compatibility.
4	PVIN	Drain of integrated power MOSFET.
5	HV	IC power supply.
6	VS	Source of integrated power MOSFET integrate, sense output current.
Bottom	GND	GND of IC.

Block Diagram

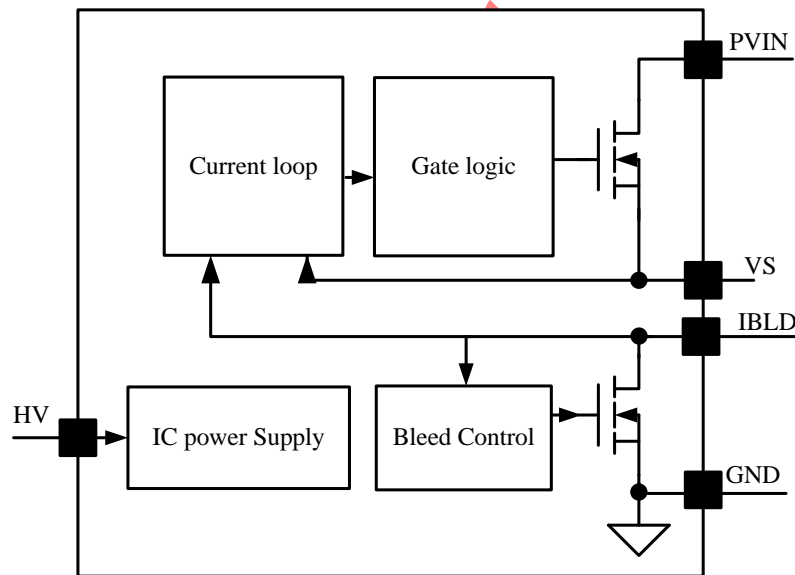

Fig2. IC block diagram



Absolute Maximum Ratings (Note 1)

PVIN-----	-0.3V to 350V
IBLD, HV-----	-0.3V to 500V
VS-----	-0.3V to 3.6V
Power Dissipation, @ $T_A = 25\text{ }^\circ\text{C}$ SO8E-----	3.3W
Package Thermal Resistance (Note 2)	
SO8E, θ_{JA} -----	30 $^\circ\text{C}/\text{W}$
SO8E, θ_{JC} -----	10 $^\circ\text{C}/\text{W}$
Temperature Range -----	-40 $^\circ\text{C}$ to 150 $^\circ\text{C}$
Lead Temperature (Soldering, 10 sec.) -----	260 $^\circ\text{C}$
Storage Temperature Range -----	-40 $^\circ\text{C}$ to 150 $^\circ\text{C}$

Electrical Characteristics

(HV= 25V (Note 3), T_A = 25 °C unless otherwise specified)

Parameter	Symbol	Test Conditions	Min	Typ	Max	Unit
Power Supply Section						
HV Turn-on Threshold	HV_ON		9.5	11	12.5	V
HV Turn-off Threshold	HV_OFF		6	7.5	9	V
BV of HV MOSFET	BV_HV			500		V
Quiescent Current	I _Q		104	126	148	μA
Inter REF Section						
Inter Current Reference	V _{REF}		97	100	103	mV
Power MOSFET Section						
BV of Integrated PVIN MOSFET	V _{PVIN}		350			V
BV of Integrated IBLD MOSFET	V _{IBLD}		500			
Thermal Section						
Thermal Fold Back Temperature	T _{FB}			148		°C

Note 1: Stresses beyond the “Absolute Maximum Ratings” may cause permanent damage to the device. These are stress ratings only. Functional operation of the device at these or any other conditions beyond those indicated in the operational sections of the specification is not implied. Exposure to absolute maximum rating conditions for extended periods may affect device reliability.

Note 2: θ_{JA} is measured in the natural convection at T_A = 25 °C on a low effective single layer thermal conductivity test board of JEDEC 51-3 thermal measurement standard. Test condition: Device mounted on 2” x 2” FR-4 substrate PCB, 2oz copper, with minimum recommended pad on top layer and thermal vias to bottom layer ground plane.

Note 3: Increase HV pin voltage gradually higher than HV_ON voltage then turn to 25V.

SO8E Package Outline & PCB layout

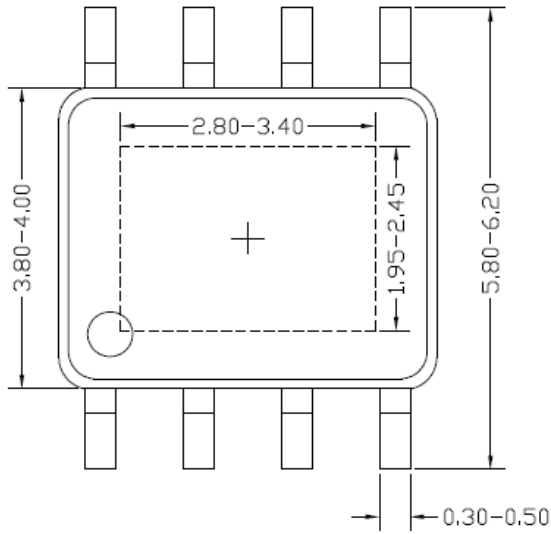

Top view

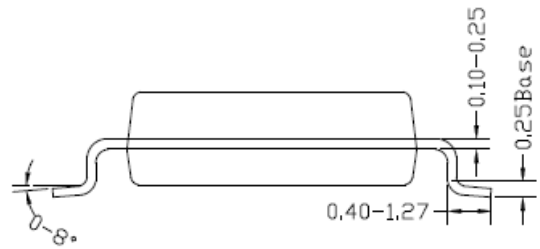

Side view

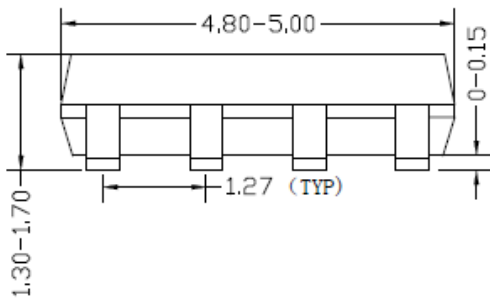

Front view

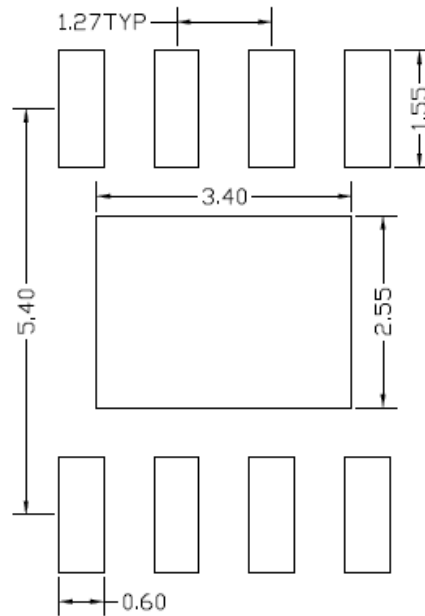

**Recommended PCB Layout
(Reference Only)**

Notes: All dimension in millimeter and exclude mold flash & metal burr.

Taping & Reel Specification

1. Taping orientation

SO8E

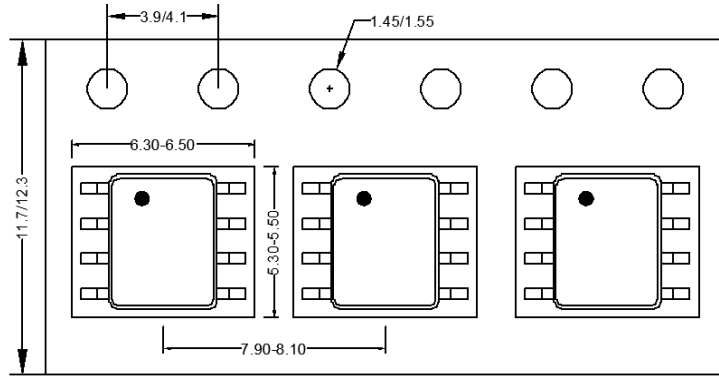

Feeding direction →

2. Carrier Tape & Reel specification for packages

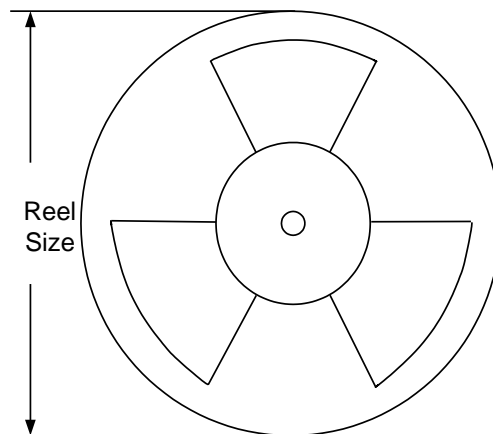

Package types	Tape width (mm)	Pocket pitch(mm)	Reel size (Inch)	Trailer * length(mm)	Leader * length (mm)	Qty per reel (pcs)
SO8E	12	8	13"	400	400	2500

Others: NA