



Application Notes: AN_SY5862

Adaptive LED Current Filter

For LED Lighting

Preliminary Specification

General Description

The SY5862 is an adaptive linear current regulator to eliminate low frequency current ripple targeting at LED lighting applications.

It is applied as a current filter to the output of a LED driver, especially single stage LED driver. It adopts adaptive control scheme and no additional electrical design is needed.

Reliable open/short LED protection and over thermal protection are all provided.

Ordering Information

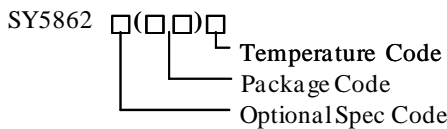

Ordering Number	Package type	Note
SY5862FAC	SO8	----
SY5862FCC	SO8E	----
SY5862JAC	TO252-3	----

Features

- Current filter for single stage LED driver to eliminate current ripple
- Proprietary scheme for low power loss $\leq 2.5\%$
- Adaptive for wide output speculation:
Output voltage range from 20V to 60V
Output current $\leq 1A$
- Open LED Protection and Short LED protection
- Reliable short LED and Open LED protection
- Compact package: SO8 SO8E TO252-3

Applications

- LED lighting

Typical Applications

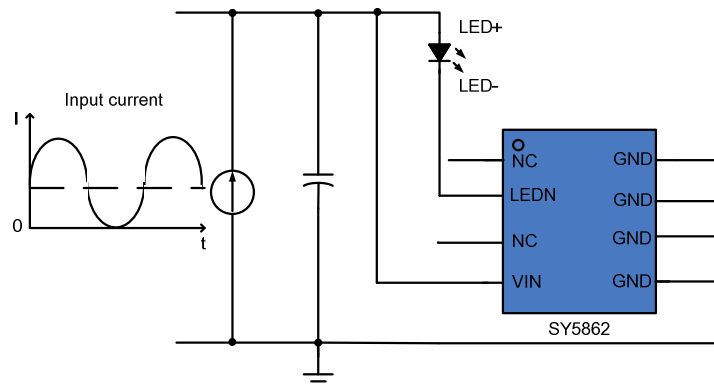
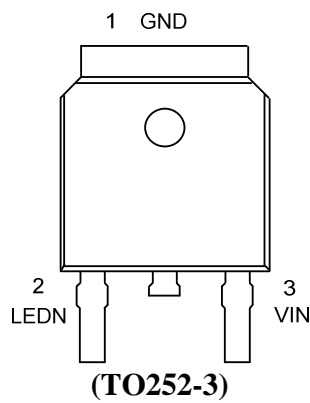
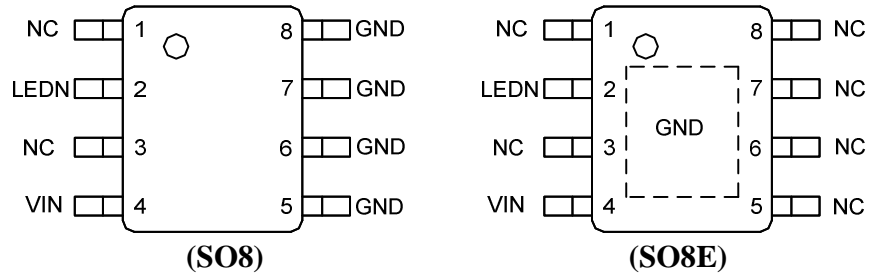

Figure 1. Schematic Diagram

Pinout (top view)



Top Mark: AYExyz for SY5862FAC (device code: AYE, *x=year code, y=week code, z=lot number code*)
AXRxyz for SY5862FCC (device code: AXR, *x=year code, y=week code, z=lot number code*)
AYDxyz for SY5862JAC (device code: AYD, *x=year code, y=week code, z=lot number code*)

Pin Name	Pin Description
LEDN	Cathode of LED string.
VIN	Power Supply
NC	NC.
GND	Ground pin



Absolute Maximum Ratings (Note 1)

VIN	-0.3V~60V
LEDN	-0.3~60V
Power Dissipation, @ TA = 25°C SO8	0.6W
Power Dissipation, @ TA = 25°C SO8E	3.3W
Power Dissipation, @ TA = 25°C TO-252	TBD
Package Thermal Resistance (Note 2)	
SO8, θ_{JA}	88°C/W
SO8, θ_{JC}	45°C/W
SO8E, θ_{JA}	30°C/W
SO8E, θ_{JC}	10°C/W
TO252-3, θ_{JA}	TBD
TO252-3, θ_{JC}	TBD
Junction Temperature Range	-40°C to 150°C
Lead Temperature (Soldering, 10 sec.)	260°C
Storage Temperature Range	-65°C to 150°C

Recommended Operating Conditions

VIN, LEDN	20V~60V
-----------	---------



Electrical Characteristics

($V_{IN} = 12V$, $T_A = 25^\circ C$ unless otherwise specified)

Parameter	Symbol	Test Conditions	Min	Typ	Max	Unit
Power Supply Section						
VIN turn-on threshold	$V_{VIN,ON}$			10		V
VIN turn-off threshold	$V_{VIN,OFF}$			7.8		V
VIN operating current	I_{VIN}			77		μA
Thermal Section						
Thermal Shutdown Temperature	T_{SD1}	$V_{LEDN} < 15V$		150		C
Thermal Shutdown Temperature	T_{SD2}	$V_{LEDN} > 15V$		100		C
Thermal Hysteresis Temperature	T_{HYS}			20		C

Note 1: Stresses beyond the “Absolute Maximum Ratings” may cause permanent damage to the device. These are stress ratings only. Functional operation of the device at these or any other conditions beyond those indicated in the operational sections of the specification is not implied. Exposure to absolute maximum rating conditions for extended periods may affect device reliability.

Note 2: Θ_{JA} is measured in the natural convection at $T_A = 25^\circ C$ on a low effective single layer thermal conductivity test board of JEDEC 51-3 thermal measurement standard. Test condition: Device mounted on 2” x 2” FR-4 substrate PCB, 2oz copper, with minimum recommended pad on top layer and thermal vias to bottom layer ground plane.

Operation

The SY5862 is an adaptive linear current regulator to eliminate low frequency current ripple targeting at LED lighting applications.

It is applied as a current filter to the output of a LED driver, especially single stage LED driver. It adopts adaptive control scheme and no additional electrical design is needed.

It is adaptive for wide output speculation, the output voltage is ranging from 20V to 60V; the maximum output current is 1A. It adopts proprietary scheme for low power loss and the efficiency loss is no more than 2.5%. It also can be operated in parallel to support higher LED current.

SY5862 provides reliable protections such as Short LED Protection (SLP), Open LED Protection (OLP), Over Temperature Protection (OTP).

SY5862 is available with SO8, SO8E and TO252-3.

Applications Information

Start up

When V_{VIN} rises up over V_{VIN-ON} , SY5862 starts to work. At first, it has 250ms blanking time without current filter function to build up stable reference internally. Then the LED current ripple is decreased by SY5862 gradually.

Shut down

When V_{VIN} drops below $V_{VIN-OFF}$, LEDN Pin is high impedance to GND Pin.

Parallel operation application

SY5862 can be operated in parallel to support higher LED current. The circuit is shown in below.

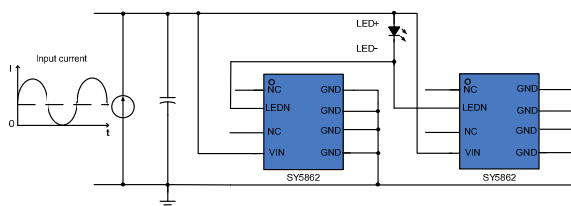
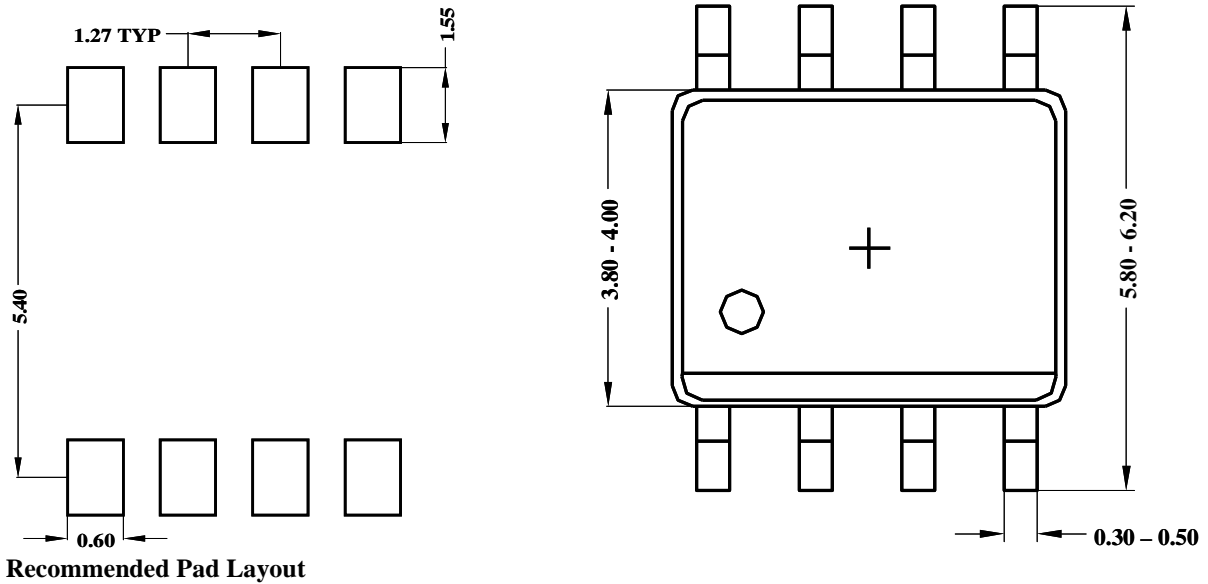
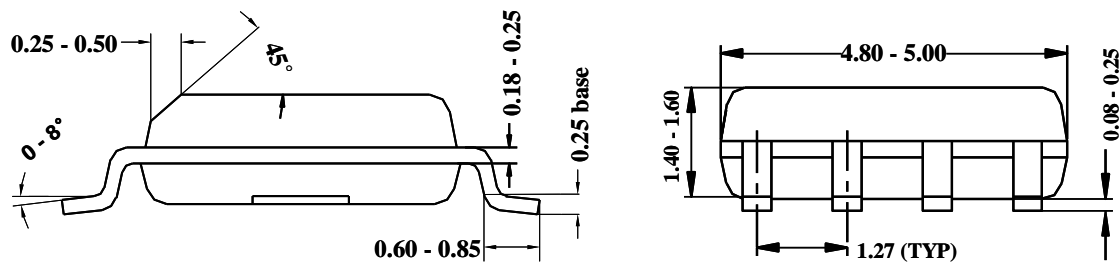

Fig. Parallel circuit

SO8 Package Outline & PCB Layout Design



Recommended Pad Layout



**Notes: All dimensions are in millimeters.
All dimensions don't include mold flash & metal burr.**

SO8-E Package Outline & PCB layout

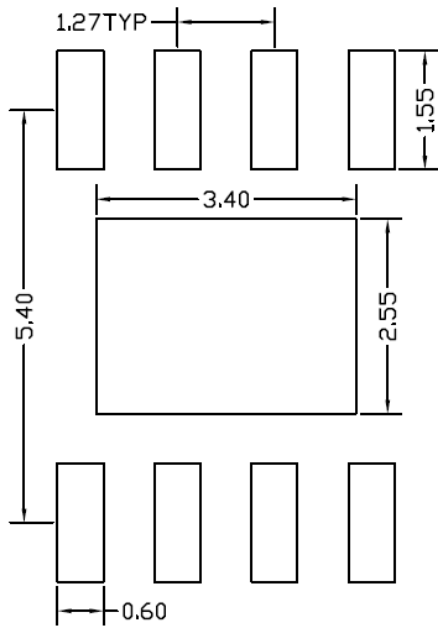

Recommended Pad Layout

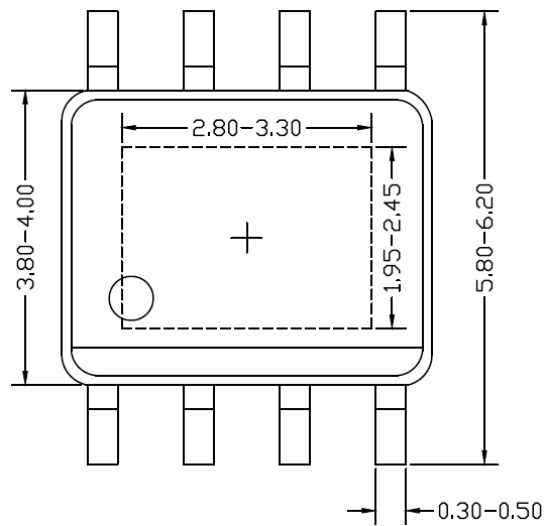

Top view

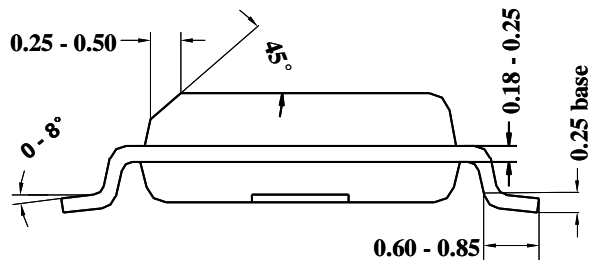

Side view

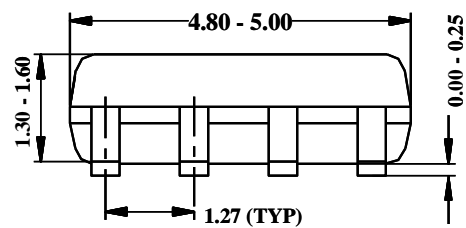

Notes: All dimension in MM
 All dimension don't not include mold flash & metal burr

TO252-3 Package Outline & PCB layout

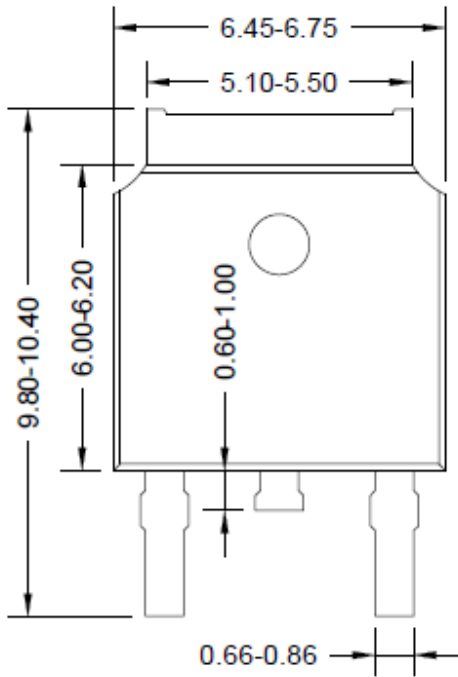

Top view

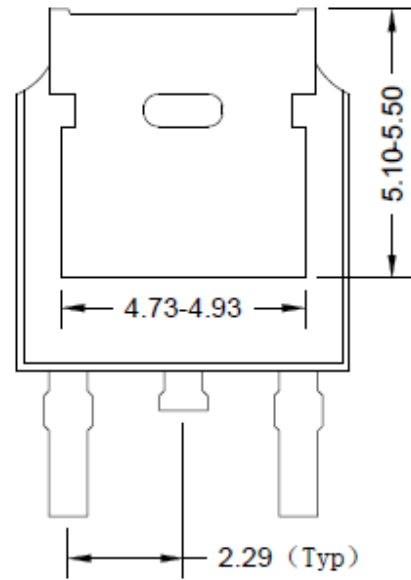

Bottom view

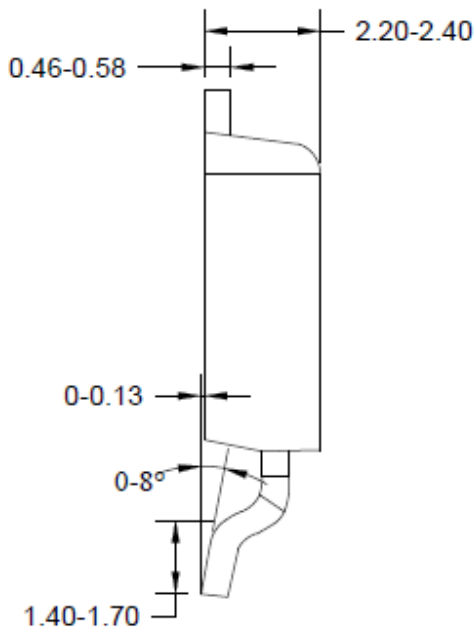

Side view

Notes: All dimension in MM and exclude mold flash & metal burr

单击下面可查看定价，库存，交付和生命周期等信息

[>>SILERGY\(矽力杰\)](#)