



# Application Note: AN\_SY50281

## Buck Regulator with CC/CV control

### General Description

The SY50281 is a PWM controller with several features to enhance performance of Buck converters. It integrates a MOSFET with 500V breakdown voltage to decrease physical volume. Both current and voltage regulation are achieved by the controller. It drives the Buck converter in the quasi-resonant mode to achieve higher efficiency and better EMI performance.

### Ordering Information

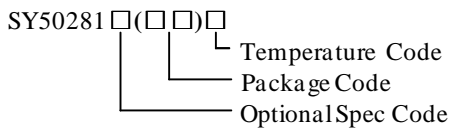

Ordering Number	Package type	Note
SY50281AAC	SOT23-5	----

### Features

- Integrated 500V MOSFET
- CC/CV control eliminates Aux-winding
- Quasi-Resonant (QR) mode to achieve low switching losses
- Fast Startup (<500ms)
- Low start up current: 15μA typical
- Maximum frequency limit: 45kHz
- Compact package: SOT23-5

### Applications

- Power supply for small appliance

Recommended operating output power @V <sub>OUT</sub> =12V	
Products	90~264Vac
SY50281	2.4W

### Typical Applications

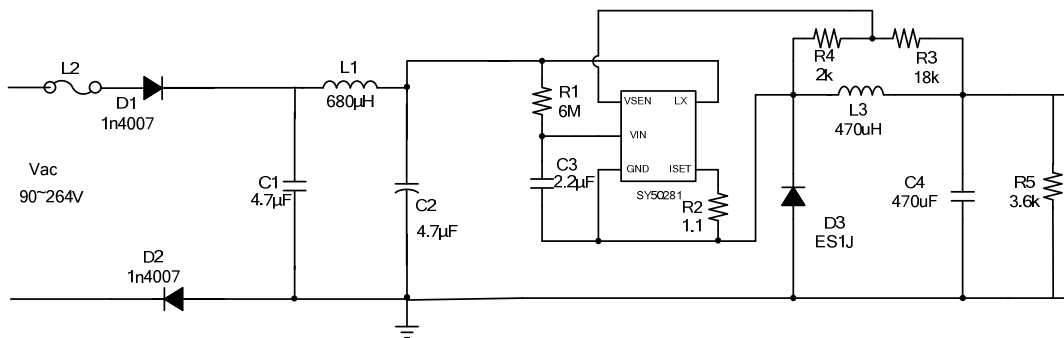
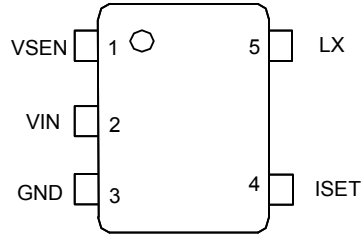

Figure 1. Schematic Diagram

**Pinout** (top view)

**(SOT23-5)**
**Top Mark: ZRxyz** (device code: ZR, *x*=year code, *y*=week code, *z*=lot number code)

Pin Name	Pin number	Pin Description
VSEN	1	Voltage sense pin. Connect to a resistor divider of inductor or auxiliary winding to sense output voltage.
VIN	2	Power supply pin.
GND	3	Ground Pin.
ISET	4	Current set pin. Connect a resistor to program the reference output current. $I_o = \frac{V_{REF}}{2R_{ISET}}$
LX	5	Internal HV MOSFET drain pin.

**Absolute Maximum Ratings** (Note 1)

ISET	-----	-0.3V~3.6V
VIN, VSEN	-----	-0.3V~17V
I <sub>VIN</sub>	-----	-20mA
I <sub>LX</sub>	-----	1.4A
LX	-----	500V
Power Dissipation, @ TA = 25°C SO-8	-----	1.1W
Package Thermal Resistance (Note 2)		
SOT23-5, θ <sub>JA</sub>	-----	88°C/W
SOT23-5, θ <sub>JC</sub>	-----	45°C/W
Maximum Junction Temperature	-----	160°C
Lead Temperature (Soldering, 10 sec.)	-----	260°C
Storage Temperature Range	-----	-65°C to 150°C

**Recommended Operating Conditions** (Note 3)

VIN	-----	8V~15.4V
Junction Temperature Range	-----	-40°C to 125°C

**Block Diagram**

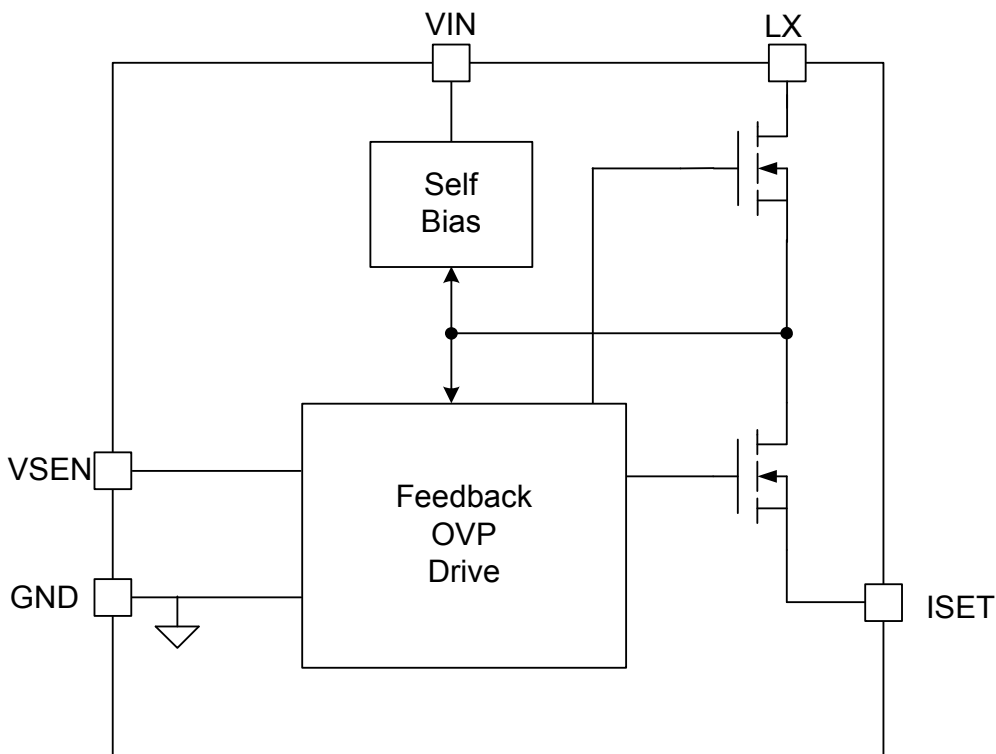

Figure2. Block Diagram



### Electrical Characteristics

( $V_{IN} = 12V$  (Note 3),  $T_A = 25^\circ C$  unless otherwise specified)

Parameter	Symbol	Test Conditions	Min	Typ	Max	Unit
Power Supply Section						
VIN turn-on threshold	$V_{VIN,ON}$			14		V
VIN turn-off threshold	$V_{VIN,OFF}$			7		V
Start up current	$I_{ST}$			15		$\mu A$
VSEN pin Section						
VSEN pin over voltage	$V_{VSEN,OV}$			$V_{VSEN,REF} \times 1.03$		V
VSEN pin reference voltage	$V_{VSEN,REF}$		1.215	1.25	1.285	V
Driver Section						
Min ON Time	$t_{ON,MIN}$			300		ns
Max ON Time	$t_{ON,MAX}$			25		$\mu s$
Min OFF Time	$t_{OFF,MIN}$			1.8		$\mu s$
Max OFF Time	$t_{OFF,MAX}$			150		$\mu s$
Max switching frequency	$f_{MAX}$			45		kHz
ISET pin Section						
Current reference	$V_{REF}$		620	675	710	mV
Integrated MOSFET Section						
BV of HV MOSFET	$V_{BV}$		500			V
Turn on Resistor	$R_{dson}$			12		
Thermal Section						
Thermal Shutdown Temperature	TSD			150		C

**Note 1:** Stresses beyond the “Absolute Maximum Ratings” may cause permanent damage to the device. These are stress ratings only. Functional operation of the device at these or any other conditions beyond those indicated in the operational sections of the specification is not implied. Exposure to absolute maximum rating conditions for extended periods may affect device reliability.

**Note 2:**  $\theta_{JA}$  is measured in the natural convection at  $T_A = 25^\circ C$  on a low effective single layer thermal conductivity test board of JEDEC 51-3 thermal measurement standard. Test condition: Device mounted on 2” x2” FR-4 substrate PCB, 2oz copper, with minimum recommended pad on top layer and thermal vias to bottom layer ground plane.

**Note 3:** Increase VIN pin voltage gradually higher than  $V_{VIN,ON}$  voltage then turn down to 12V.

## Operation

The SY50281 is a high performance controller with constant current and constant voltage.

It integrates a 500V MOSFET to decrease physical volume.

In order to reduce the switching losses and improve EMI performance, Quasi-Resonant switching mode is applied, which means to turn on the power MOSFET at valley of drain voltage; the start up current of SY50281 is rather small (15μA typically) to reduce the standby power loss further; the maximum switching frequency is clamped to 45kHz to reduce switching losses and improve EMI performance when the converter is operated at light load condition.

SY50281 provides reliable protections such as Short Circuit Protection (SCP), Over Voltage Protection (OVP), Over Temperature Protection (OTP), etc.

SY50281 is available with SOT23-5 package.

## Applications Information

### Start up

After AC supply or DC BUS is powered on, the capacitor  $C_{VIN}$  across VIN and GND pin is charged up by BUS voltage through a start up resistor  $R_{ST}$ . Once  $V_{VIN}$  rises up to  $V_{VIN\_ON}$ , the internal blocks start to work.  $V_{VIN}$  will be pulled down by internal consumption of IC until the Buck inductor could supply enough energy to maintain  $V_{VIN}$  above  $V_{VIN\_OFF}$ .

The whole start up procedure is divided into two sections shown in Fig.3.  $t_{STC}$  is the  $C_{VIN}$  charged up section, and  $t_{STO}$  is the output voltage built-up section. The start up time  $t_{ST}$  composes of  $t_{STC}$  and  $t_{STO}$ , and usually  $t_{STO}$  is much smaller than  $t_{STC}$ .

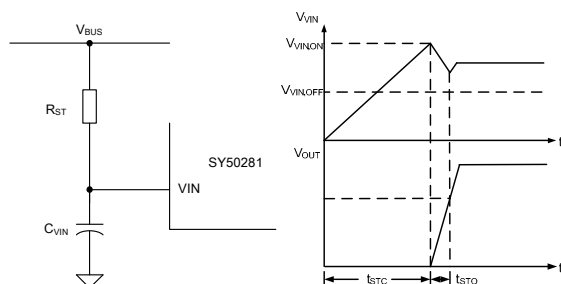

Fig.3 Start up

The start up resistor  $R_{ST}$  and  $C_{VIN}$  are designed by rules below:

(a) Preset start-up resistor  $R_{ST}$ , make sure that the current through  $R_{ST}$  is larger than  $I_{ST}$  and smaller than  $I_{VIN\_OVP}$

$$R_{ST} < \frac{V_{BUS}}{I_{ST}} \quad (1)$$

Where  $V_{BUS}$  is the BUS line voltage.

(b) Select  $C_{VIN}$  to obtain an ideal start up time  $t_{ST}$ , and ensure the output voltage is built up at one time.

$$C_{VIN} = \frac{\left(\frac{V_{BUS}}{R_{ST}} - I_{ST}\right) \times t_{ST}}{V_{VIN\_ON}} \quad (2)$$

(c) If  $R_{ST}$  and  $C_{VIN}$  are chosen to a very small start up time, SCP and OVP power loss will be large. Then  $C_{VIN}$  and  $R_{ST}$  time constant should be increased.

Proprietary self-bias technique allows  $C_{VIN}$  to be charged every switching cycle. There is no need to add auxiliary winding for power supply.  $C_{VIN}$  can be chosen with small value and small package to save cost

### Shut down

After AC supply or DC BUS is powered off, the energy stored in the BUS capacitor will be discharged. When power supply for IC is not enough,  $V_{VIN}$  will drop down. Once  $V_{VIN}$  is below  $V_{VIN\_OFF}$ , the IC will stop working.

### Quasi-Resonant Operation

QR mode operation provides low turn-on switching losses for Buck converter.

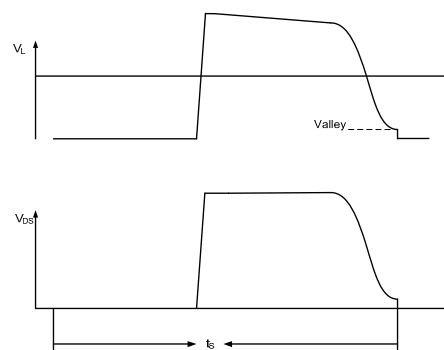

Fig.4 QR mode operation

ZCS pin detects the inductor voltage by a resistor divider. When the voltage across drain and source of the integrated MOSFET is at voltage valley, the MOSFET would be turned on.

### Output Voltage Control

In order to achieve constant voltage control. The output voltage is sampled by detecting the inductor voltage.

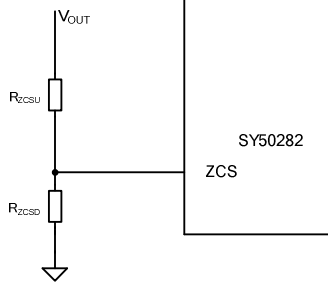

Fig.5 ZCS pin connection

As shown in Fig.6, during OFF time, the voltage across the inductor is

$$V_L = V_{OUT} + V_{D,F} \quad (3)$$

$V_{D,F}$  is the forward voltage of the power diode;  $V_L$  is the voltage across the inductor.

At the current zero-crossing point,  $V_{D,F}$  is nearly zero, so  $V_{OUT}$  is proportional with  $V_L$  exactly. The voltage of this point is sampled by the IC as the feedback of output voltage. The resistor divider is designed by.

$$\frac{V_{ZCS\_REF}}{V_{OUT}} = \frac{R_{ZCSD}}{R_{ZCSU} + R_{ZCSD}} \quad (4)$$

Where  $V_{ZCS\_REF}$  is the internal voltage reference.

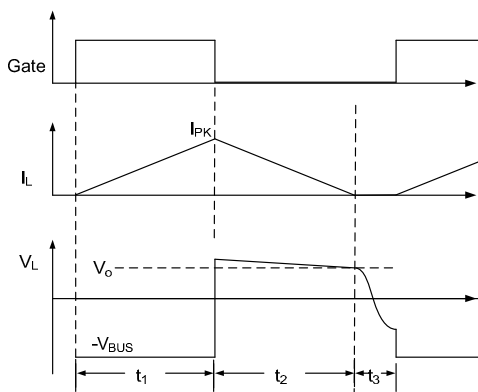

Fig.6 inductor voltage waveforms

### Constant-current control

The switching waveforms are shown in Fig.7. The output current  $I_{OUT}$  can be represented by,

$$I_{OUT} = \frac{I_{PK}}{2} \times \frac{t_{EFF}}{t_s} \quad (5)$$

Where  $I_{PK}$  is the peak current of the inductor;  $t_{EFF}$  is the effective time of inductor current rising and falling;  $t_s$  is the switching period.

$I_{PK}$  and  $t_{EFF}$  can be detected by ISET and VSEN pin, which is shown in Fig.7. These signals are processed and applied to the negative input of the gain modulator. In static state, the positive and negative inputs are equal.

$$V_{REF} = I_{PK} \times R_{ISET} \times K \times \frac{t_{EFF}}{t_s} \quad (6)$$

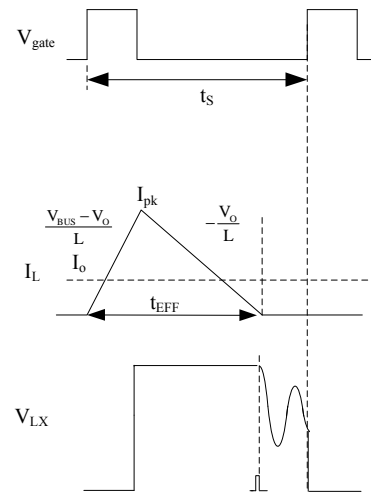

Fig.7 switching waveforms

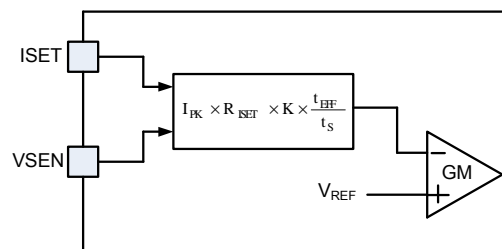

Fig.8 Output current detection diagram

Finally, the output current  $I_{OUT}$  can be represented by

$$I_O = \frac{V_{REF}}{2R_{ISET}} \quad (7)$$

Where  $V_{REF}$  is the internal reference voltage;  $R_{ISET}$  is the current set resistor.  $I_{OUT}$  can be programmed by  $R_{ISET}$ .

$$R_{ISET} = \frac{V_{REF}}{2I_{OUT}} \quad (8)$$

When over current operation or short circuit operation happens, the output current will be limited at  $I_{OUT,LIM}$ . The V-I curve is shown as Fig.9.

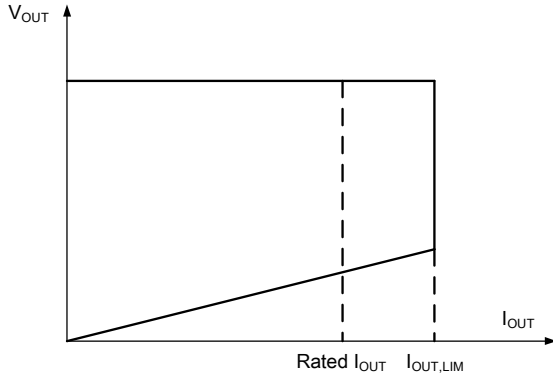

Fig.9 V-I curve

### Line regulation modification

The IC provides line regulation modification function to improve line regulation performance.

Due to the sample delay of ISET pin and other internal delay, the output current increases with increasing input BUS line voltage. A small compensation voltage  $\Delta V_{ISET,C}$  is added to ISET pin during ON time to improve such performance. This  $\Delta V_{ISET,C}$  is adjusted by the upper resistor of the divider connected to VSEN pin.

$$\Delta V_{ISET,C} = (V_{BUS} - V_O) \times \frac{k_1}{R_{ZCSU}} \times R_{ISET} \quad (8)$$

Where  $R_{ZCSU}$  is the upper resistor of the divider;  $k_1$  is an internal constant as the modification coefficient.

The compensation is mainly related with  $R_{ZCSU}$ , larger compensation is achieved with smaller  $R_{ZCSU}$ .

### Short Circuit Protection (SCP)

When the output is shorted, demagnetizing voltage of inductor is zero, so  $t_{OFF}$  will be clamped at  $t_{OFF,MAX}$ , when  $t_{OFF,MAX}$  shows up for 64 times, SCP is triggered and the IC will discharge  $V_{VIN}$  by an internal current source  $I_{VIN,SCP}$ . Once  $V_{VIN}$  is below  $V_{VIN,OFF}$ , the IC will shut down and be charged again by BUS voltage through start

up resistor. If the short circuit condition still exists, the system will operate in hiccup mode.

### Power design

A few applications are shown as below.

Input range	Output	
90Vac~264Vac	2.4W	12V/0.2A

## Power Device Design

### MOSFET and Diode

When the operation condition is with maximum input voltage and full load, the voltage stress of the integrated MOSFET and output power diode is maximized;

$$V_{MOS,DS,MAX} = \sqrt{2}V_{AC,MAX} \quad (9)$$

$$V_{D,R,MAX} = \sqrt{2}V_{AC,MAX} \quad (10)$$

Where  $V_{AC,MAX}$  is maximum input AC RMS voltage.

When the operation condition is with minimum input voltage and full load, the current stress of MOSFET and power diode is maximized.

### Inductor (L)

In Quasi-Resonant mode, each switching period cycle  $t_s$  consists of three parts: current rising time  $t_1$ , current falling time  $t_2$  and quasi-resonant time  $t_3$  shown in Fig.11.

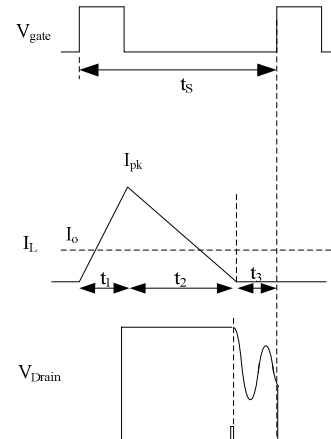

Fig.11 switching waveforms

When the operation condition is with minimum input AC RMS voltage and full load, the switching frequency is minimum frequency, the maximum peak current through integrated MOSFET and the transformer happens.

Once the minimum frequency  $f_{S-MIN}$  is set, the inductance of the transformer could be induced. The design flow is shown as below:

(a) Preset minimum frequency  $f_{S-MIN}$

(b) Compute relative  $t_s, t_1$

$$t_s = \frac{1}{f_{S-MIN}} \quad (11)$$

$$t_1 = \frac{t_s \times (V_{OUT} + V_{DF})}{(\sqrt{2}V_{AC-MIN} + V_{DF})} \quad (12)$$

$$t_2 = t_s - t_1 \quad (13)$$

Where  $V_{DF}$  is the forward voltage of the diode

(c) Compute inductor L and maximum peak current  $I_{PK}$ .

$$I_{L-PK-MAX} = 2 \times I_O \quad (14)$$

$$L = \frac{(\sqrt{2}V_{AC-MIN} - V_O) \times t_1}{I_{L-PK-MAX}} \quad (15)$$

(f) Compute RMS current of the inductor

$$I_{L-RMS-MAX} = \frac{I_{L-PK-MAX}}{\sqrt{3}} \quad (16)$$

(g) Compute RMS current of the MOSFET

$$I_{MOS-RMS-MAX} = I_{L-PK-MAX} \times \sqrt{\frac{t_1}{3t_s}} \quad (17)$$

### **inductor design (N)**

the parameters below are necessary:

Necessary parameters	
Inductance	L
inductor maximum current	$I_{L-PK-MAX}$
inductor maximum RMS current	$I_{L-RMS-MAX}$

The design rules are as followed:

(a) Select the magnetic core style, identify the effective area  $A_e$ .

(b) Preset the maximum magnetic flux  $\Delta B$

$$\Delta B = 0.22 \sim 0.26T$$

(c) Compute inductor turn N

$$N = \frac{L \times I_{L-PK-MAX}}{\Delta B \times A_e} \quad (18)$$

(d) Select an appropriate wire diameter

With  $I_{L-RMS-MAX}$ , select appropriate wire to make sure the current density ranges from  $4A/mm^2$  to  $10A/mm^2$ .

(c) If the winding area of the core and bobbin is not enough, reselect the core style, go to (a) and redesign the transformer until the ideal transformer is achieved.

### **Input capacitor C<sub>BUS</sub>**

Generally, the input capacitor  $C_{BUS}$  is selected by

$$C_{BUS} = 1 \sim 3\mu F / W$$

Or more accurately by

$$C_{BUS} = \frac{\arcsin\left(1 - \frac{\Delta V_{BUS}}{\sqrt{2}V_{AC-MIN}}\right) + \frac{\pi}{2}}{\pi} \times \frac{P_{OUT}}{\eta} \times \frac{1}{2f_{IN} V_{AC-MIN}^2 \left[1 - \left(1 - \frac{\Delta V_{BUS}}{\sqrt{2}V_{AC-MIN}}\right)^2\right]} \quad (19)$$

Where  $\Delta V_{BUS}$  is the voltage ripple of BUS line.

## **Layout**

(a) To achieve better EMI performance and reduce line frequency ripples, the output of the bridge rectifier should be connected to the BUS line capacitor first, then to the switching circuit.

(b) The circuit loop of all switching circuit should be kept small.

(c) bias supply trace should be connected to the bias supply capacitor first instead of GND pin. The bias supply capacitor should be put beside the IC.

(d) Loop of 'Source pin – current sample resistor – GND pin' should be kept as small as possible.

(e) The resistor divider connected to ZCS pin is recommended to be put beside the IC.

(f) The control circuit is recommended to be put outside the power circuit loop.



## Design Example1

Design Specification			
$V_{AC}(RMS)$	90V~264V	$V_{OUT}$	12V
$I_{OUT}$	200mA	$\eta$	70% (full load)
Inductor (Buck)	470uH	$R_{SET}$	1.1Ohm
$C_{INPUT}$	11.5uF	$C_{OUTPUT}$	470 uF
$R_{ZCSU}$	38k $\Omega$	$R_{ZCSD}$	4.3k
Rload	3.6k $\Omega$		

## Design Example2

Design Specification			
$V_{AC}(RMS)$	90V~264V	$V_{OUT}$	12V
$I_{OUT}$	100mA	$\eta$	70% (full load)
Inductor (Buck)	1mH	$R_{SET}$	1.1Ohm
$C_{INPUT}$	5.5uF	$C_{OUTPUT}$	330 uF
$R_{ZCSU}$	38k $\Omega$	$R_{ZCSD}$	4.3k
Rload	3.6k $\Omega$		

## Design Example3

Design Specification			
$V_{AC}(RMS)$	90V~264V	$V_{OUT}$	5V
$I_{OUT}$	200mA	$\eta$	70% (full load)
Inductor (Buck)	680uH	$R_{SET}$	0.9Ohm
$C_{INPUT}$	5.5uF	$C_{OUTPUT}$	470uF
$R_{ZCSU}$	14.3k $\Omega$	$R_{ZCSD}$	4.3k
Rload	1k $\Omega$		

## Design Example4

Design Specification			
$V_{AC}(RMS)$	90V~264V	$V_{OUT}$	5V
$I_{OUT}$	100mA	$\eta$	70% (full load)
Inductor (Buck)	1mH	$R_{SET}$	1.1Ohm
$C_{INPUT}$	2.2uF	$C_{OUTPUT}$	100uF
$R_{ZCSU}$	14.3k $\Omega$	$R_{ZCSD}$	4.3k
Rload	1k $\Omega$		

## Circuit schematic

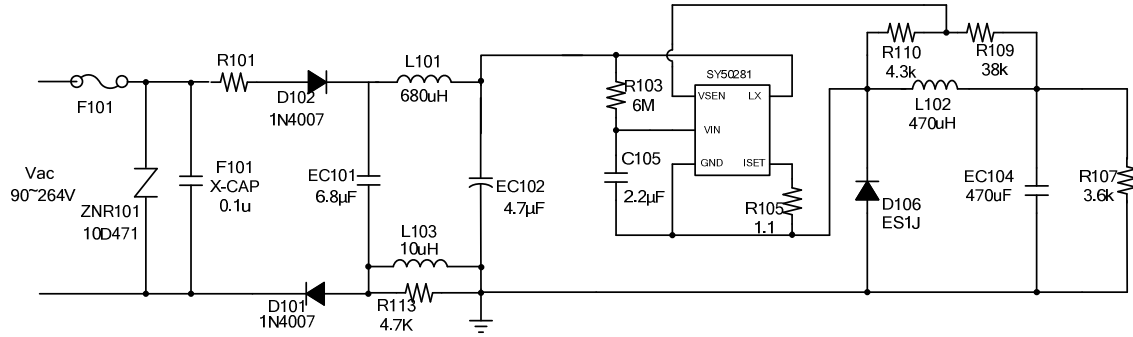

Example for 12V/0.2A

SOT23-5 Package outline & PCB layout design

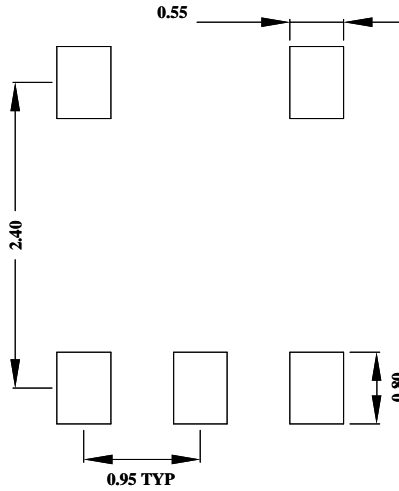

Recommended Pad Layout

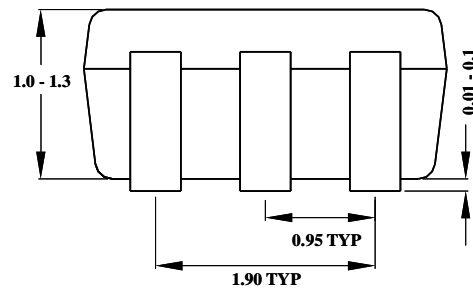
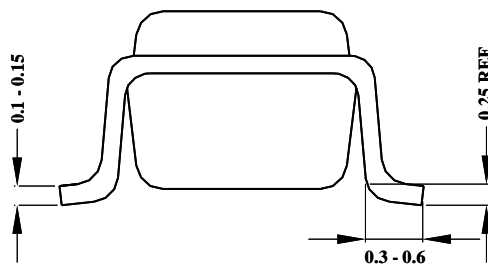
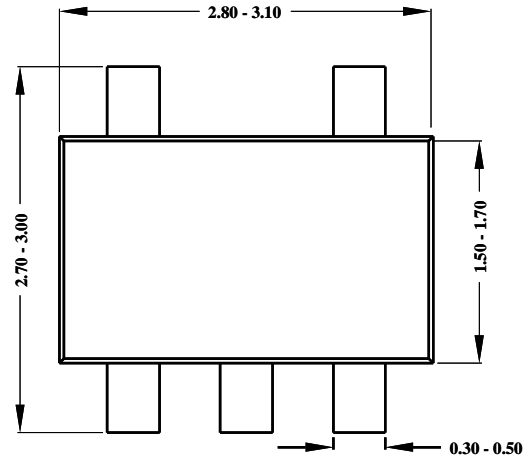

**Notes:** All dimensions are in millimeters.  
 All dimensions don't include mold flash & metal burr.

## Taping & Reel Specification

### 1. SOT23-5 taping orientation

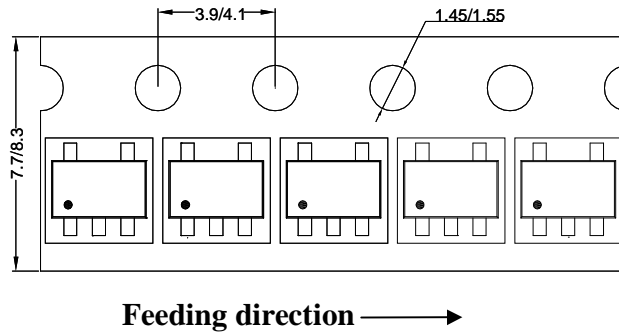

### 2. Carrier Tape & Reel specification for packages

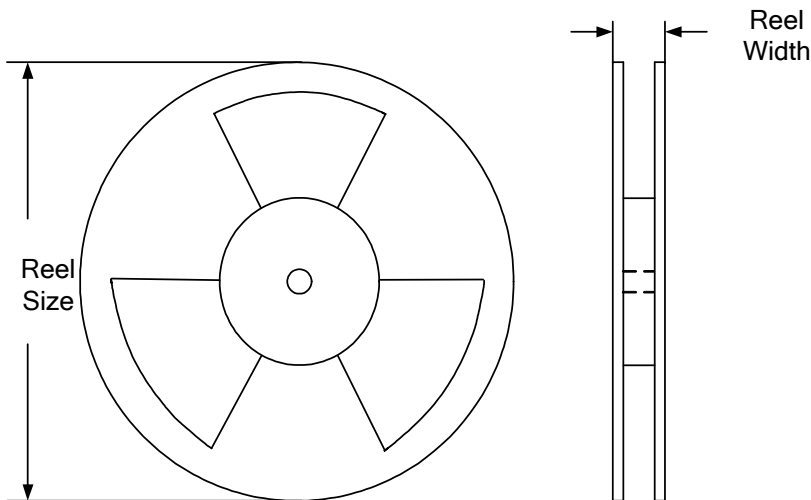

Package types	Tape width (mm)	Pocket pitch(mm)	Reel size (Inch)	Reel width(mm)	Trailer length(mm)	Leader length (mm)	Qty per reel
SOT23-5	8	4	7"	8.4	280	160	3000

### 3. Others: NA

单击下面可查看定价，库存，交付和生命周期等信息

[>>SILERGY\(矽力杰\)](#)